

Chapter NR 112

WELL CONSTRUCTION AND PUMP INSTALLATION

NR 112.01	Purpose (p. 227)	NR 112.14	Surface protection (p. 260)
NR 112.02	Applicability (p. 227)	NR 112.15	Miscellaneous well construction and pump installation requirements (p. 262)
NR 112.03	Definitions (p. 227)	NR 112.16	Samples and reports (p. 265)
NR 112.035	Department review times (p. 235)	NR 112.17	Pump installation and construction (p. 267)
NR 112.04	Approved comparable construction (p. 235)	NR 112.18	Well construction equipment (p. 299)
NR 112.05	Existing installations (p. 235)	NR 112.19	Concrete and grout mixtures (p. 299)
NR 112.06	Contracts for nonconforming installations (p. 236)	NR 112.20	Well disposal of pollutants (p. 308)
NR 112.07	Well location (p. 236)	NR 112.21	Abandonment of wells (p. 308)
NR 112.08	Drilled type well design and construction (p. 239)	NR 112.22	Cooperation with the department (p. 309)
NR 112.085	Well casing pipe (p. 245)	NR 112.23	Standards for existing installations (p. 309)
NR 112.09	Bored type well design and construction (p. 250)	NR 112.24	Severability (p. 312-1)
NR 112.10	Driven point type well design and construction (p. 251)	NR 112.26	Well and pump installation approvals (p. 312-1)
NR 112.11	Dug type well design and construction (p. 254)	NR 112.27	Drinking water standards (p. 316)
NR 112.12	Reconstructing dug type wells (p. 257)		
NR 112.13	Springs (p. 258)		

History: Chapter NR 112 as it existed on September 30, 1975 was repealed and a new chapter NR 112 was created effective October 1, 1975.

NR 112.01 Purpose. The purpose of this chapter is to establish uniform minimum standards and methods of procuring and protecting an adequate supply of ground water safe and fit for human consumption and for the preparation of food products through adequate construction or reconstruction of wells and reservoirs, installation of pumping equipment, or other methods approved by the department, in conformity with chs. 144 and 162, Stats. This chapter shall govern the location, construction or reconstruction and maintenance of wells and reservoirs, the installation and maintenance of pumping and treatment equipment, and the supervision of well drillers and pumping equipment installers.

History: Cr. Register, June, 1975, No. 234, eff. 10-1-75; am. Register, April, 1978, No. 268, eff. 5-1-78.

NR 112.02 Applicability. The provisions of this chapter shall apply to all new and existing private water supplies, high capacity water systems, school water systems, and public water systems, except those for community water systems serving 15 or more living units.

Note: An approval from the department is required for high capacity water systems, school water systems and sewage treatment plant water systems pursuant to chs. 144 and 162, Stats., respectively, prior to construction of any well and installation of any pump. See NR 112.26.

History: Cr. Register, June, 1975, No. 234, eff. 10-1-75; am. Register, April, 1978, No. 268, eff. 5-1-78; am. Register, September, 1978, No. 273, eff. 10-1-78.

NR 112.03 Definitions. For the purpose of this chapter the following terms are defined as follows:

(1) "Absorption pond" means an earth structure constructed for the purpose of slow disposal of treated sewage or other liquid wastes by soil seepage.

(2) "Adequate water supply" means a water supply which has a yield, where obtainable, and the pump capacity to provide the quantity of water which the user has stated is necessary for drinking, culinary, food processing and other purposes for which the water is intended to be used.

(3) "Animal enclosure" means a fenced yard or similar uncovered structure in which an area of 600 square feet or less is provided for each animal unit contained therein and in which animals are enclosed for any part of at least 30 separate days per year.

(4) "Animal lot" means a fenced yard or similar uncovered structure in which the concentration of livestock or poultry is such that a vegetative cover is not maintained.

(5) "Animal shelter" (paved) means a paved covered structure including but not limited to a house or barn in which animals are enclosed for at least any part of 30 separate days per year.

(6) "Animal shelter" (unpaved) means unpaved covered structures including but not limited to houses or barns in which animals are enclosed for at least any part of 30 separate days per year.

(7) "Animal unit" means an equivalent of 1,000 pounds of live animal weight.

(8) "Animal yard" means fenced in dirt or concrete area in which cattle or other livestock or poultry are enclosed and includes animal enclosures, animal lots, and animal shelters defined in subs. (3), (4) and (5) above.

(9) "Annular space" means the space between 2 concentric cylinders or circular objects, such as the space between an upper enlarged drillhole and initial protective casing pipe or between the initial protective casing pipe and an outer construction pipe or inner liner pipe or between an inner liner pipe and lower drillhole.

(10) "Approval" means the written approval of the department.

(11) "Cistern" means a covered tank in which rainwater from roof drains is stored.

(11m) "Clay" means an inorganic soil with characteristics of low permeability and plasticity index (PI) of more than 7.

(12) "Clay slurry" means a fluid mixture of native clay formation or commercial clay or clay mineral products and water prepared with only the amount of water necessary to produce fluidity.

(12m) "Community water system" means a public water system which serves at least 15 service connections used by year-round residents or regularly serves at least 25 year-round residents.

(13) "Contaminant" means any matter which may render water bacteriologically or chemically impure or turbid so as to make it unfit for human consumption.

(14) "Clear water waste" means cooling water and condensate drainage from refrigeration compressors and air-conditioning equipment, waste water drainage from equipment chilling processes, foundation drainage water and other water having no impurities or where impurities are of such minimum concentration as not to be considered harmful and cooled condensate from steam heating systems or other equipment.

(15) "Drainage system" means the piping within public or private premises, which conveys sewage, rainwater or other liquid wastes to the point of disposal, but does not include the mains of a public sewerage system or private or public sewage treatment plant.

(16) "Department" means the department of natural resources.

(17) "Drawdown" means the extent of lowering of the water level or water pressure in a well when water is pumped or flows from it.

(18) "Lower drillhole" means that part of a drillhole below the vertical zone of contamination.

(19) "Upper drillhole" means that part of the cased drillhole, augerhole or excavation constructed through the vertical zone of contamination.

(20) "Upper enlarged drillhole" means that portion of upper drillhole, larger in diameter than the protective well casing and extending through all or part of the vertical zone of contamination.

(20m) "Drinking water standards" means those standards listed in ch. NR 109.

(21) "Driven point well" means a well constructed by joining a "drive point" with a length of pipe, extended as may be necessary, and driving the assembly into the ground, without a preliminary excavation in excess of 10 feet in depth. All other types of wells, including those constructed by a combination of jetting and driving, are drilled type wells.

(22) "Established grade" means the permanent point of contact of the ground or artificial surface with the casing pipe or curbing of the well.

(23) "Established ground surface" means the permanent elevation of the surface of the site of the well.

(24) "Existing installations" means those which are not newly constructed or reconstructed prior to the effective date of provisions of ch. NR 112 in effect at the time of the inspection.

(25) "Regional flood" means a flood determined by the department to be representative of large floods known to have generally occurred in Wisconsin and which may be expected to occur on a particular stream because of like physical characteristics. The regional flood generally has an average frequency of the 100-year recurrence interval flood.

(26) "Flood plain", for the purpose of this chapter, means the land adjacent to a body of water which has been or may be hereafter covered by the regional flood.

(27) "Floodway", for the purpose of this chapter, means the channel of a stream and those portions of the flood plain adjoining the channel

that are required to carry and discharge the flood waters or flood flows of any river or stream associated with the regional flood.

(28) "Flushing" means the act of causing a rapid flow of water from a well by pumping, bailing or similar operation.

(29) "Grease basin" means a watertight tank installed underground for the collection and retention of grease from cooking or food processing and which is accessible for periodic removal of the contents.

(30) "Ground water" means that part of subsurface water which is in the zone of saturation.

(30m) "High capacity water supply or system" means one where new and existing wells to be constructed, reconstructed, rehabilitated, installed or operated on one property whose operating capacity singly or in the aggregate with that of other wells on the property will be in excess of 70 gallons per minute.

(31) "Holding tank" means a watertight receptacle approved by the department of health and social services for the retention of sewage.

(33) "Liner pipe" means either protective well casing pipe installed subsequent to initial construction to seal off a zone of bacterial or chemical contamination or casing pipe installed during or subsequent to the initial well construction to seal off a caving formation.

(34) "Liquid-manure holding tank" means a structure completely fabricated on-site out of reinforced poured concrete or equivalent concrete or out of steel having approved lining material, with or without a cover, used for containing animal wastes consisting of excreta, leachings, feed losses, litter, washwaters or other associated wastes.

(34m) "Liquid-tight concrete floor" means, for the purpose of s. NR 112.07 (2) (j) and (o), a floor equivalent to one with a thickness of at least 5 inches; poured, Portland cement concrete containing at least 5½ bags of cement per cubic yard of concrete, having a medium consistency with not more than 6 gallons of water per bag of cement including water in the aggregate; and with minimum reinforcing steel of 6" x 6" x 10-gauge welded wire fabric placed within the center ½ of the slab thickness, except that should the floor be expected to be subjected to heavy equipment use, the fabric steel shall be heavier gauge.

(34o) "Living unit" means a domicile.

(34p) "Manure storage basin" means a large, relatively shallow depth excavation for storage of manure with bottom completely below grade and constructed either completely with earthen bottom and earthen sides; or with concrete floor and earthen sides or sides other than concrete; or with concrete floor and partial concrete walls and the remainder of the side walls being earthen.

(34q) "Manure hopper" means a relatively small receptacle for receiving manure scrapings from a gutter or barn floor or yard for the purpose of pushing the manure by a piston-type pump to a manure storage structure.

(34r) "Manure tank for pneumatic pumping" means a relatively small volume steel tank having provision for pumping air into it and

pneumatically forcing the semi-liquid manure to a liquid-manure holding tank.

(35) "Near-surface water" means water in the zone immediately below the ground surface. It may include seepage from barnyards, leaching pools and disposal beds or leakage from sewers, drains and similar sources of contaminated water.

(35a) "Non-community water supply system" means a public water system that is not a community water system.

(35c) "Nonpotable water supply" or "nonpotable well" means an excavation or opening into the ground made by digging, boring, drilling, driving or other methods for the purpose of obtaining groundwater for a use other than human consumption or preparation of food products.

(35m) "One property" means all contiguous lands controlled by one owner, lessee, or any other person having a possessory interest. For the purposes of this chapter, lands under single ownership bisected by highways or railroad right-of-ways are considered contiguous.

(36) "Permit" means a written approval issued by the department.

(37) "Preparation of food products" means washing, cooling, cooking, pasteurizing, bottling, canning, or otherwise preparing food for human consumption, and including the washing of utensils and equipment used in production or preparation of food.

(38) "Private water supply" means one or more sources of ground water, including facilities for storage and conveyance thereof, such as wells, springs, pumps, pressure tanks and reservoirs, on one property, other than those serving a public water system.

(39) "Privy" means a building structure used for the deposition of human body wastes.

(40) "Protective well casing" means pipe meeting standards specified in NR 112.085, which is driven or set to seal off the vertical zone of contamination.

(40m) "Public water system" means a system for the provision to the public of piped water for human consumption, if such system has at least 15 service connections or regularly serves an average of at least 25 individuals daily at least 60 days out of the year. A public water system is either a "community water system" or a "non-community water system". Such system includes:

(a) Any collection, treatment, storage and distribution facilities under control of the operator of such system and used primarily in connection with such system, and

(b) Any collection or pretreatment storage facilities not under such control which are used primarily in connection with such system.

(41) "Pump installer" means any person, firm or corporation who is duly registered as such with the department, has paid the annual registration fee and has obtained a permit to engage in pump installing.

(42) "Pumping water level" means the elevation of the surface of the water in a well or water pressure at the top of a flowing artesian well after a period of pumping or flow at the customary rate.

(42m) "Reception tank" means a relatively small temporary manure-holding structure into which manure is scraped or flushed at the barn and from which it is pumped into a manure storage structure.

(43) "Retention pond" means an excavated or diked structure or combination of structures designed for interception and temporary storage of runoff water contaminated by leachings, washwaters or similar liquid wastes on farms or on other property where cattle or other livestock are raised.

(44) "Reservoir" means a facility for storage of water for drinking or culinary purposes constructed entirely or partially below the ground surface.

(45) "Safe water" means water that is free from contaminating matter.

(46) "Sanitary condition" (a) When referring to a well or reservoir means that the construction of the well or reservoir and the installation of the pumping equipment are such that the well or reservoir is effectively protected against entrance of contaminating matter.

(b) When referring to the surroundings of a well or reservoir means that the location and the surrounding area are free from debris or filth of any character and not subject to flooding.

(46m) "School water supply or system" means a water system serving an educational institution.

(47) "Seepage bed" means an excavated area similar to a seepage trench but larger than 3 feet in width and containing more than one distribution line.

(48) "Seepage pit" means an underground receptacle so constructed as to permit disposal of septic tank effluent, milkhouse washwater, silage juices, clear water wastes and similar wastes by soil absorption through its walls and bottoms.

(49) "Seepage trench" means an area excavated 3 feet or less in width which contains a bedding of aggregate and a single distribution line.

(50) "Septic tank" means a watertight tank which receives sewage.

(51) "Sewage" means any water carried wastes created in and conducted away from residences, industrial establishments and public buildings with such surface or ground water as may be present and for the purpose of these rules includes any other liquid wastes except clear water wastes.

(51m) "Sewage treatment plant water supply or system" means a self-supplied water system for a sewage treatment plant for drinking, toilet, laboratory, showers, eye wash fountains, plant wash-down and sewage disinfection purposes.

(52) "Sewer" means any conduit used or intended to be used for conveying sewage.

(53) "Sanitary building sewer" means that part of the plumbing system beginning at the immediate outside foundation or proposed foundation wall and extending to its connection with the main of a public sewer, private sewer, private sewage disposal system or other point of disposal.

(54) "Sanitary building drain" means the lowest horizontal piping of a drainage system which receives the discharge from soil, waste and other drainage pipes inside any building and conveys same to the building sewer by gravity flow. The minimum building drain extends from the building sewer to all soil stacks.

(55) "Sanitary building subdrain" means the horizontal portion of a drainage system within a building which cannot flow by gravity to the building drain.

(56) "Solid manure storage structure" means a structure used for stacking or composting and containment of animal wastes consisting of excreta, feed losses, litter or associated solid wastes.

(57) "Specific capacity" means the continuous yield of a well at a given well water or pressure drawdown expressed in gallons per minute, per foot of drawdown.

(58) "Static water level" means that elevation of the surface of the water in a well or water pressure at the top of a well, in the case of some artesian wells, when no water is being pumped or flows therefrom. In the case of artesian wells with a positive water pressure at the top of the well, the static water elevation is determined either by a stilling pipe or pressure gauge and under either condition water elevations are referred to the elevation of the top of the well or the ground grade at the well.

(59) "Storm sewer" means any conduit used or intended to be used for conveying surface water runoff, clear water waste and subsoil drainage with such ground water as may be present.

(60) "Storm building sewer" means that part of the storm water system which receives the discharge from building storm drains and subdrains, parking lots, yard fountains and other similar sources, and conveys such waters to a public storm water system, private storm water system or other approved point of disposal.

(61) "Storm building drain" means the lowest horizontal piping which receives storm waters or other similar water from roofs, area ways, courtyards, canopies, enclosed parking ramps and other sources inside any building or structure and conveys same to the storm building sewer by gravity flow.

(62) "Storage pond" means an excavated or diked earthen structure including partially fabricated liquid manure holding tanks designed for containing animal wastes consisting of excreta, leachings, feed losses, litter, washwaters or other associated liquid wastes.

(63) "Stuffing box" means an approved receptacle in which packing may be compressed to form a watertight or airtight junction between 2 objects.

(64) "Subsoil drain" means that part of the drainage system which conveys the ground or seepage water from the footings of walls or below

the basement floor under buildings to the storm sewer or other point of disposal.

(65) "Sump" means a tank or pit which receives sewage or other liquid wastes located below the normal grade of a gravity system and which must be emptied by mechanical means.

(66) "Treatment pond" means an earth structure with sealed bottom and walls constructed for the purpose of holding sewage or other liquid waste for a period of time to reduce BOD and suspended solids.

(67) "Vertical zone of contamination" means that depth of geologic formations, generally near the ground surface, containing connecting pore spaces, crevices or similar openings, including artificial channels, such as unprotected wells, through which contaminated water may gain access to a well or the ground water body.

(68) "Watertight construction" means cased and grouted construction through firm formations like clay or rock. Through granular material like sand or gravel, it means that the casing pipe is of approved quality and assembled watertight.

(69) "Well" means an excavation or opening into the ground made by digging, boring, drilling, driving or other methods for the purpose of obtaining groundwater for human consumption. For purposes of s. NR 112.20, "well" includes any similar excavation or opening where the depth is greater than the largest surface dimension, regardless of its intended use.

(70) "Well cap" means an approved removable non-watertight apparatus or device used to cover a well.

(71) "Well driller" means any person, firm or corporation who has duly registered as such with the department, has paid the annual registration fee and has obtained a permit to construct wells.

(72) "Well seal" means an approved removable apparatus or device used as follows:

(a) To close the well opening watertight or to establish and maintain a watertight junction between the upper terminal of protective casing or curbing of a well and the piping or equipment installed therein, so as to prevent water from entering the well; or

(b) To establish and maintain a watertight junction between the basement end of non-pressure pipe conduit, installed between a well and a building basement, and the pump piping installed within the conduit.

(73) "Well vent" means an outlet at the upper end of the well casing or basement end of a non-pressure conduit to allow equalization of air pressure in the well.

(74) "Yield" means the quantity of water which may flow or be pumped from the well per unit of time.

History: Cr. Register, June, 1975, No. 234, eff. 10-1-75; renum. (55) to (73) to be (56) to (74), cr. (55), Register, March, 1977, No. 255, eff. 4-1-77; cr. (12m), (20m), (30m), (34m), (35a), (35m), (40m), (46m) and (51m), am. (38) and r. (32), Register, April, 1978, No. 268, eff. 5-1-78; am. (34), renum. (34m) to be (34o), cr. (11m), (34m), (34p), (34q), (34r), (35c) and (42m), Register, October, 1981, No. 310, eff. 11-1-81; am. (24) and (40), Register, October, 1982, No. 322, eff. 11-1-82; am. (69), Register, December, 1982, No. 324, eff. 1-1-83.

NR 112.035 Department review times. Unless another time period is specified by law, the department shall complete its review and make a determination on all of the following applications for permits and approvals within 65 business days after receipt of the application:

- (1) Well drilling and pump installing permits under s. 162.04, Stats;
- (2) Approvals of comparable construction specifications under s. NR 112.04;
- (3) Approvals of granite wells with less than 40 feet of casing under s. NR 112.08, Table 1, line 1;
- (4) Approvals of well casing pipe testing procedures under s. NR 112.085;
- (5) Approvals of water supply equipment and supplies under ss. NR 112.13, 112.14, 112.15, and 112.17;
- (6) Permits for pits for pumps, pressure tanks and wells under s. NR 112.14;
- (7) Blasting permits under s. NR 112.15;
- (8) Chemical and non-chemical conditioning permits under s. NR 112.15;
- (9) Approvals of drilling aids under s. NR 112.15;
- (10) Approvals of pressure vessels and pressure vessel paints under s. NR 112.17;
- (11) Approvals of grout additives under s. NR 112.19
- (12) Approvals of high capacity wells under s. 144.025(2)(e), Stats., and s. NR 112.26;
- (13) Approvals of school water supplies under s. NR 112.26; and
- (14) Approvals of sewage treatment plant water supplies under s. NR 112.26.

History: Cr. Register, March, 1985, No. 351, eff. 4-1-85.

NR 112.04 Approved comparable construction. When strict compliance with this chapter appears to be impracticable, the reasons therefor shall be communicated in writing to the department for advice and approval of comparable specifications.

History: Cr. Register, June, 1975, No. 234, eff. 10-1-75.

NR 112.05 Existing installations. Existing well, pump, pressure tank, pit, subsurface pumphoom and reservoir installations that conform to s. NR 112.23 are acceptable. Noncomplying existing well, pump, pressure tank, pit, subsurface pumphoom and reservoir installations shall be corrected to comply with s. NR 112.23 or the specifications in this chapter for new construction.

History: Cr. Register, June, 1975, No. 234, eff. 10-1-75.

NR 112.06 Contracts for nonconforming installations. Well drillers and pump installers shall ensure that the construction and reconstruction of

wells or appurtenances thereto or the installation of pumping equipment adheres to all the applicable provisions of this chapter or to approved comparable requirements. Well drillers and pump installers shall not enter into any agreement, written or oral, for such construction, reconstruction or installation which does not require compliance with all applicable provisions of this chapter or with approved comparable requirement.

History: Cr. Register, June, 1975, No. 234, eff. 10-1-75.

NR 112.07 Well location. (1) **GENERAL.** Where a well is constructed to supply ground water for human consumption and preparation of food products, such well shall be located:

(a) In such manner that the well and its surroundings can be kept in a sanitary condition.

(b) At the highest point on the premises consistent with the general layout and surroundings, but in any case protected against surface water flow and flooding.

(c) As far removed from any known or probable source of contamination as the general layout of the premises and the surroundings permit.

(2) **RELATION TO CONTAMINATION SOURCES.** Unless modified by written department approval under NR 112.04, minimum separating distances between wells or reservoirs and sources of contamination shall be maintained as follows:

(a) Eight feet between well or reservoir and cast iron or equivalent sanitary or storm building sewer or sanitary or storm building drain or a basement floor drain connected to a cast iron or equivalent sanitary building sewer or sanitary building drain; cast iron or equivalent sub-drain; cast iron or equivalent sewage sump; cast iron or equivalent milkhouse floor drain; cast iron or equivalent drain from a conventional silo or glass lined storage facility, cast iron or equivalent sewer conducting manure juices to point of disposal.

(b) Ten feet between well and independent clear water waste drain, rainwater downspout outlet, cistern, hydrant drain, or similar unit; building foundation-drain connected to independent clear water waste drain or other subsoil drain; nonconforming existing or unapproved new well pit, pump pit, pressure-tank pit, pressure-tank access pit or subsurface pumphoom; nonconforming reservoir except that for school water systems, high capacity water systems and sewage treatment plant water systems there shall be a minimum separating distance of 20 feet between a well or reservoir and a well pit, pump pit, pressure-tank pit, pressure-tank access pit, or subsurface pumphoom.

(c) Fifteen feet between well and sewer-connected foundation drain.

(d) Twenty-five feet between well or reservoir and watertight grease basin, septic tank, holding tank, subdrain other than cast iron or equivalent pipe; sewage sump other than cast iron or equivalent material; sanitary building or storm building sewer other than cast iron or equivalent material; sanitary building or storm building drain other than cast iron or equivalent material; floor drain connected to sanitary building sewer or drain of other than cast iron or equivalent pipe material;

lake or stream shoreline; below-ground swimming pool except that for school water systems and high capacity water systems the minimum separating distance between a well and a lake or stream shoreline shall be 60 feet.

(e) Twenty-five feet between well or reservoir and watertight barn gutter; animal barn pen with concrete floor; glass-lined storage facility without pit; conventional silo without pit but with concrete floor and proper drain; watertight, milkhouse floor drain other than cast iron or equivalent material; watertight, conventional silo drain or glass-lined storage facility drain other than cast iron or equivalent material; watertight nonpressurized sewer other than cast iron or equivalent material conveying manure juices; pressure pipe used to convey manure, providing the pipe is PVC pipe meeting ASTM specification D-2241, with standard dimension ratio of 21 or less; or pressure pipe meeting the requirements of s. NR 110.13 (6) (f) or 111.71.

(f) Twenty-five feet between well or reservoir and a pressurized sewer, other than a street sanitary or storm sewer or similar sanitary or storm sewer piping comprising part of the drainage system on public or private property, for which the required minimum separating distance between a well or reservoir and such sewers is specified in par. (h).

(g) Fifty feet between well or reservoir and seepage pit, seepage bed, seepage trench or other similar sewage or waste water disposal unit; privy; pet-waste pit disposal unit; animal yard, animal shelter, animal enclosure or animal lot; conventional silo with pit; glass-lined storage facility with pit; outlet of watertight milkhouse drain; seepage pit for drain of conventional silo or glass-lined storage facility; pressure pipe used to convey manure if the pipe does not meet the specifications listed in par. (e); loose-jointed field-drain pipe lines except that for school water supply systems, there shall be a minimum separating distance of 200 feet between a well or reservoir and seepage pit, seepage bed, seepage trench or similar sewage or waste water disposal unit.

(h) Fifty feet between well or reservoir and street sanitary or storm sewer; similar sanitary or storm sewer piping comprising part of the drainage system on public or private property except that for sewage treatment plant wells, there shall be a minimum separating distance of 150 feet between a well or reservoir and a gravity or pressurized collector, branch or trunk sewer.

(i) Seventy-five feet between well or reservoir and liquid-tight steel or concrete reception tank or hopper used in a semi-solid or liquid-manure handling system from which manure is pumped to a liquid-manure storage facility; liquid-tight manure tank for pneumatic pumping, providing the floors of such structures are constructed at least 3 feet above both bedrock and the highest groundwater level. When bedrock or the highest groundwater level is at a lesser depth than 3 feet below the bottom of the structure, a variance under s. NR 112.04 may be considered when:

1. A separating distance of at least 100 feet will be provided, but in no case shall a separating distance greater than 150 feet be required.

2. A design providing comparable protection will be planned.

(j) One hundred feet between well or reservoir and a temporary manure stack; solid manure storage platform with liquid-tight concrete floor on grade or partially below grade; liquid-tight reinforced poured concrete or equivalent concrete fabricated liquid-manure holding tank; liquid-tight steel liquid-manure holding tank, having glass lining or equivalent corrosion resistant material; manure storage basin with liquid-tight concrete floor and walls; earthen silage storage trench or pit, provided, the floors of any such liquid-manure tanks or basins are constructed at least 3 feet above both bedrock and the highest groundwater level. When bedrock or the highest groundwater level is at a lesser depth than 3 feet below the bottom of these structures, a variance under s. NR 112.04 may be considered when:

1. A separating distance of at least 150 feet will be provided, but in no case shall a separating distance greater than 175 feet be required.

2. A design providing comparable protection will be planned.

(k) One hundred feet between well or reservoir and bulk subsurface storage tanks for refined petroleum products such as gasoline and fuel oil, except in the case of fuel oil tanks for private residential use, in which case the separating distance shall be at least 25 feet or farther where practical.

(l) One hundred feet between well or reservoir and nearest existing or future grave sites in cemeteries.

(m) One hundred and fifty feet between well or reservoir and sewage treatment plant structures.

(n) Two hundred feet between well or reservoir and sludge disposal area on same property or adjoining property.

(o) 1. Two hundred feet between well or reservoir and a solid or semi-solid manure storage basin, if the structure is located in sand or sand and gravel; and at least 150 feet between a well or reservoir and such basins, if evidence is provided to the department that the existing soil is clay extending to a depth of at least 5 feet below the structure, but in either case subject to the further limitations:

a. The structure will have a liquid-tight concrete floor.

b. The structure will have an acceptable drainage facility, as defined in subd. 3.

c. A structure governed by this subsection shall be constructed at least 5 feet above both bedrock and the highest groundwater level.

2. If bedrock or the highest groundwater level is at a lesser depth than 5 feet, the well or reservoir location shall comply with par. (p).

3. For the purpose of this subsection, "acceptable drainage facility" means, as it pertains to manure storage basins, slatted or mesh-covered openings on one side or wall of the basin discharging to a sewer pipe meeting material requirements as specified by the state plumbing code for building sewers or a liquid-tight reinforced, poured, Portland cement flume extending to a holding lagoon or pond.

(p) Two hundred fifty feet between well or reservoir and an absorption, storage, retention or treatment pond; ridge and furrow waste disposal site; or a spray irrigation waste disposal site; manure storage basin, other than those described in par. (o) 1., providing the bottom of the structure is constructed at least 3 feet above both bedrock and the highest groundwater level. When bedrock or the highest groundwater level will be at a lesser depth than 3 feet below the bottom of the facility, a variance under s. NR 112.04 may be considered when:

1. A separating distance of at least 275 feet will be provided, but in no case shall a separating distance greater than 300 feet be required.

2. A design providing comparable protection will be planned.

(q) Four hundred yards between well or reservoir and the nearest edge of an existing or proposed sanitary land fill disposal site.

(r) For the purpose of pars. (a), (d) and (e), the term "equivalent" means, as it pertains to a cast iron sewer, drain or subdrain, approved plastic pipe as listed and limited in Wis. Adm. Code ch. H 62 (State Plumbing Code) for specific uses and as it pertains to a sewage sump, a plastic sump fabricated from a plastic material approved by the division of health, department of health and social services.

(3) RELATION TO BUILDINGS. With respect to buildings the location of a well shall be as follows:

(a) When a well is located outside and adjacent to a building, it shall be located so that the center line of the well extended vertically will clear any projection from the building by not less than 2 feet.

(b) Every well shall be located so that it will be reasonably accessible with proper equipment for cleaning, treatment, repair, test, inspection, and such other maintenance as may be necessary.

(c) No well shall be located nor shall a building extension be constructed so that the top of the well will be within the basement of any building or building extension or under a building or building extension having no basement.

(4) RELATION TO FLOOD PLAINS. (a) Wells may be constructed and replaced on property on the flood plain outside of the floodway provided that the top of the well is terminated a minimum of 2 feet above the regional flood elevation for the well site.

Note: This is the required minimum elevation of the first floor of any new building in the flood plain.

(b) A well may be reconstructed or replaced on property in a floodway provided that a permit is first obtained from the department.

(c) No well may be constructed on floodway property that is either undeveloped or has building structures but no existing well.

Note: Attention of well drillers and pump installers is called to ch. PSC 114, State Electrical Code, volume 1, Wis. Adm. Code, for restrictions on proximate locations of well drilling and pump installing equipment relative to electric power lines.

History: Cr. Register, May, 1975, No. 233, eff. 5-1-75; am. (2) (a), (b), (d) and (e), renum. (2) (f) to (m) to be (2) (g) to (n), cr. (2) (f) and (o), Register, March, 1977, No. 255, eff. 4-1-77; am. (2) (b), (d), (g), (h) and (j), renum. (2) (l) thru (o) to be (2) (m) thru (p), cr. (2) (l), Register, April, 1978, No. 268, eff. 5-1-78; am. (2) (e) and (g), renum. (2) (i) to (p) to be (2) (j) to (n), (p) to (r), cr. (2) (i) and (o), am. (2) (j) and (p), Register, October, 1981, No. 310, eff. 11-1-81.

NR 112.08 Drilled type well design and construction. (1) **GENERAL.** The construction of every well shall be planned and carried out so that it will be:

(a) Adapted to the geologic (earth structure) and ground water conditions existing at the site of the well so as to insure full utilization of every natural protection afforded thereby against contamination of water bearing formations and to exclude known sources of contamination.

(b) Designed to permit such supplementary construction as may be required to provide a sufficient and safe water supply, where obtainable, and to conserve ground water.

(c) Capable of satisfying where obtainable, the yield requirements of an "adequate water supply".

(2) **SPECIFIC.** The requirements of sub. (1) for drilled-type wells for low capacity supplies, including community systems serving less than 15 living units and non-community systems, but excluding schools, shall be deemed to be fulfilled when the minimum construction and material requirements set forth in s. NR 112.085, table 1 and in pars. (a) through (e) are met, and for high capacity water systems and school water systems when minimum construction and material requirements of table 3 and also pars. (a) through (e) are met, except for sewage treatment plant water systems, where a minimum of 100 feet of well casing pipe shall be installed.

Note: See appendix figures A1 through A25 for low capacity water supply standards required by table 1.

(a) *Bit sizes.* 1. Cable-tool drilling. Cable tool bits shall have a size no smaller than $\frac{1}{8}$ inch less than the nominal diameter of the drillhole to be constructed at the beginning of construction of a new rock hole or at the beginning of deepening of any existing rock hole. The bits shall be kept dressed.

2. Rotary drilling. a. Cone bits. Cone bits shall have a minimum size not less than $\frac{1}{8}$ inch smaller than the nominal diameter of the drillhole to be constructed.

b. Hammer bits. Hammer bits shall have a size no smaller than $\frac{1}{8}$ inch less than the nominal diameter of the drillhole to be constructed at the beginning of drilling of a new rock hole or at the beginning of deepening of any existing rock hole.

NR 112

(b) *Liner pipe for caving zones.* Liner pipe installed during or subsequent to the initial well construction to seal off a caving zone in a well shall be new, unused and non-reclaimed pipe but may have a lesser thickness than shown in table 2 for the nominal diameter of pipe used and may have the largest practical diameter permitting installation in the well.

(c) *Rotary-air drilling.* When constructing wells with combination rotary and cable-tool equipment, the respective drilling methods shall comply with the requirements for rotary-air drilling and for cable-tool drilling.

(d) *Water used in drilling.* Water needed in the construction of drillholes shall be clear water obtained from an uncontaminated source. Such water should be disinfected with chlorine so as to reduce to a minimum the time and effort involved in the required final disinfection of the well.

Note: See NR 112.15 (3) (a).

(e) *Drilling delays following grouting.* Following placement of grout in the annular space between a protective well casing pipe and upper enlarged drillhole or between a protective liner pipe and lower drillhole and protective well casing pipe, drilling shall be delayed for a minimum of 24 hours, whether using either cable-tool or rotary equipment.

(3) **FLOWING WELLS.** The construction of flowing wells shall comply with the minimum requirements of sub. (2) and the following special conditions:

(a) Every practicable effort shall be made to extend the watertight (cased and cement grouted) construction into the upper confining bed of the artesian basin.

(b) When it is impractical to extend the watertight construction in accordance with par. (a), an adequate packer shall be set and maintained in the confining bed with a flowpipe extending therefrom to a point at least one foot above the established grade.

(c) The driller shall temporarily install an approved well seal with overflow pipe extending therefrom, if necessary, in which case a control valve shall be installed in the overflow pipe and the flow therefrom either limited or stopped.

Note: See figure 1.

History: Cr. Register, June, 1975, No. 234, eff. 10-1-75; am. table 1, Register, March, 1977, No. 255, eff. 4-1-77; am. (2) (intro.) and (a), Register, April, 1978, No. 268, eff. 5-1-78; r. and recr. (2) (d), Register, June, 1981, No. 306, eff. 10-1-81; am. (2) (intro.), renum. (2) (a) to (d) to be NR. 112.085 (1) (a) to (d), renum. (2) (e) to (i) to be (2) (a) to (e), Register, October, 1982, No. 322, eff. 11-1-82.

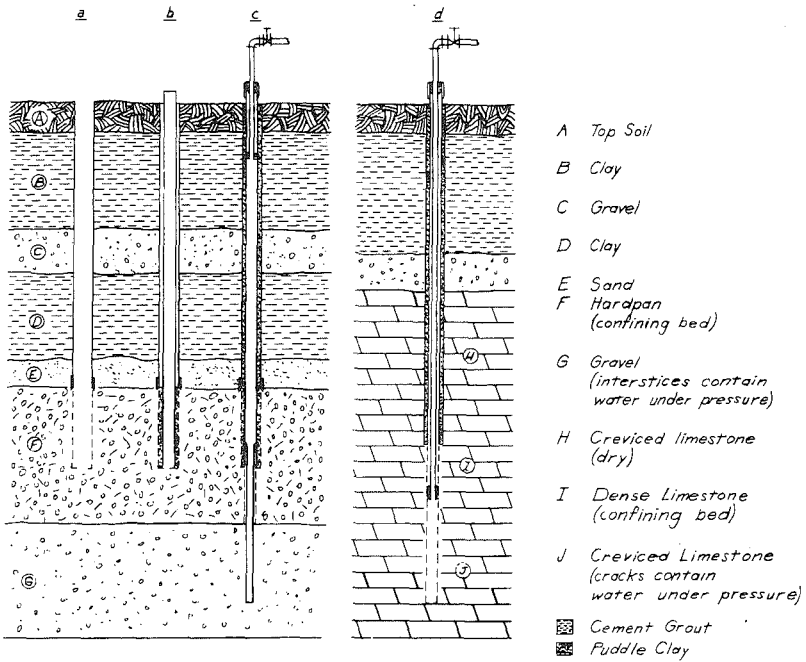

Figure 1. Principle of Construction and Control of Flowing Wells.

Next page is numbered 241

TABLE I
DRILLED TYPE WELL REQUIREMENTS

1 TYPE	2 NATURE OF WATER BEARING FORMATION (AQUIFER)	3 GEOLOGIC FORMATIONS OVERLYING AQUIFER	4 MINIMUM NOMINAL CASING DIAMETER INCHES	5 UPPER DRILLHOLE				9 LOWER DRILLHOLE MINIMUM WELL DIAMETER	10 MAXIMUM NOMINAL PROTECTIVE LINER DIAMETER	11 CONSTRUCTION CONDITIONS
				UPPER ENLARGED DRILLHOLE		REGULAR DRILLHOLE				
				5 MINIMUM DIAMETER	6 MINIMUM DEPTH	7 MINIMUM DIAMETER	8 BOTTOM ELEVATION			
a.	Sand or gravel	Sand or mixture of sand and gravel.	2"	None required with cable tool drilling but shall be casing diameter plus 4" if one is constructed. See construction conditions. Casing diameter plus 2" with rotary drilling.	None required with cable tool drilling. To depth of casing setting with rotary drilling.	2"	See Construction Conditions		The depth of protective well casing pipe will be governed by the pumping level. For pumping levels 20' or less the casing shall extend 10' below the pumping level. For pumping levels 20' to 25' the casing shall extend to a depth of 30'. For pumping levels greater than 25' the casing shall extend 5' below the pumping level. When an enlarged upper drillhole is constructed with cable tool equipment, the annular space shall be filled with clay slurry or cement grout placed in an approved manner. See Note 2 below. With rotary drilling, the upper enlarged drillhole shall be maintained at full diameter with drilling mud and the annular space shall be permanently sealed with drilling mud or cement grout. See Note 1 below. Also see Appendix.	a,b,c Protective well casing placed in an upper enlarged drillhole only 2" greater in diameter than the nominal well casing pipe diameter, as is only permissible with rotary-air drilling, shall be assembled with welded joints and sealed in place with drilling mud or cement grout placed in the annular space by a suitable pump from the bottom of the casing upward. An adequate screen shall be provided where necessary. It shall be installed in such manner that removal or replacement can be accomplished without adversely affecting the watertight construction of the well.
b.	Sand or gravel	Clay or similar material to depth of 30' or more, containing layers of sand or gravel.	2"	Casing diameter plus 4" with cable tool drilling. Casing diameter plus 2" with rotary drilling. See construction conditions.	5' into clay below any sand or gravel above the 20' depth with cable tool drilling. To depth of casing placement with rotary drilling.	2"	See Construction Conditions		The protective well casing pipe shall extend 5' below the pumping level. With cable tool drilling the upper enlarged drillhole shall be kept open with temporary well casing and the upper drillhole shall be kept 1/3 filled with clay slurry throughout the driving of the permanent well casing. The balance of the annular space shall be filled with clay slurry or cement grout. With rotary drilling, the upper enlarged drillhole shall be maintained at full diameter with drilling mud and the annular space shall be permanently sealed with drilling mud or cement grout. See Note 1 below. Also see Appendix.	An adequate screen shall be provided where necessary. It shall be installed in such manner that removal or replacement can be accomplished without adversely affecting the watertight construction of the well.
c.	Sand or gravel	Clay or similar material from the ground surface to varying depths.	2"	Casing diameter plus 4" with cable tool drilling. Casing diameter plus 2" with rotary drilling. See construction conditions.	To the bottom of the clay or a minimum of 20' whichever is the lesser with cable tool drilling. To the depth of casing setting with rotary drilling.	2"	See Construction Conditions		See (a-11) above for minimum casing depth requirements. With cable tool drilling, the upper drillhole shall be kept 1/3 filled with clay slurry throughout the driving of the permanent well casing. The balance of the annular space shall be filled with clay slurry or cement grout. With rotary drilling the upper enlarged drillhole shall be maintained at full diameter with drilling mud and the annular space shall be permanently sealed with drilling mud or cement grout. See Note 1 below. Also see Appendix.	Approval from the Department is required for a gravel-pack well construction in conformance with Section NR 112.04.

NOTE 1. Greater depth of casing is required in areas where well histories show that the vertical zone of contamination extends to a greater depth.
NOTE 2. Some drillers construct an enlarged upper drillhole to a depth of several feet with cable tool equipment by choice under geologic conditions of column 3, line a, to facilitate use of long lengths of pipe.

TABLE I
DRILLED TYPE WELL REQUIREMENTS

1 TYPE	2 NATURE OF WATER BEARING FORMATION (AQUIFER)	3 GEOLOGIC FORMATIONS OVERLYING AQUIFER	4 MINIMUM NOMINAL CASING DIAMETER INCHES	5 UPPER DRILLHOLE				9 LOWER DRILLHOLE MINIMUM WELL DIAMETER	10 MAXIMUM NOMINAL PROTECTIVE LINER DIAMETER	11 CONSTRUCTION CONDITIONS	
				5 UPPER ENLARGED DRILLHOLE		6 REGULAR DRILLHOLE					
				5 MINIMUM DIAMETER	6 MINIMUM DEPTH	7 MINIMUM DIAMETER	8 BOTTOM ELEVATION				
p.	Sandstone	Limestone to depth of 40' or less with or without unconsolidated overburden over the limestone.	6"	Casing diameter plus 4" with cable tool drilling. Casing diameter plus 2" with rotary drilling. See construction conditions.	15' into firm sandstone.	Not applicable.		6"	2" less than the lower drillhole diameter.	The upper enlarged drillhole through caving formations above the rock shall be kept open by temporary well casing with cable tool drilling and by such casing or drilling mud with rotary drilling. If the formation over the rock is clay or material which will similarly stand open, with rotary drilling the drill cuttings preferably shall be removed by mud but use of air will be permitted for such geologic formation. The annular space surrounding the protective well casing shall be permanently filled with cement grout. The vertical zone of contamination must be sealed off. See Note 2 below. Also see Appendix.	pq Protective well casing pipe placed in an upper enlarged drillhole only 2" greater in diameter than the nominal well casing pipe diameter, shall be assembled with welded joints and sealed in place with cement grout placed in the annular space by a suitable pump from the bottom of the casing upward. Protective liner pipe shall be assembled with welded joints, placed concentrically within the drillhole and sealed in place with cement grout placed by a suitable pump or other approved method from the bottom of the liner pipe upward.
q.	Sandstone	limestone extending to a depth greater than 40' with or without unconsolidated overburden over the limestone.	6"	Casing diameter plus 4" with cable tool drilling. Casing diameter plus 2" with rotary drilling. See construction conditions.	40' or 10' into uncreviced rock below 30'.	Not applicable.		6"	2" less than the lower drillhole diameter.	The upper enlarged drillhole diameter need be only 2" greater than the nominal well casing pipe diameter when the well casing pipe is assembled with welded joints and the cement grout is placed in the annular space by a suitable pump or other approved pressure method from the bottom of the casing upward.	

NOTE 1. Although the carbonate rocks in this state are primarily dolomites, the term limestone has been given to them in the well construction specifications because it is the common term given to them by the drillers.
NOTE 2. Casing only to the depth indicated in column 6, lines p & q, for conditions of column 3, lines p & q, is only acceptable as a minimum when it is adequate to seal off the vertical zone of contamination. Greater depth of protective casing is required in areas where well histories show that the vertical zone of contamination extends to a greater depth.

TABLE I
DRILLED TYPE WELL REQUIREMENTS

1 TYPE	2 NATURE OF WATER BEARING FORMATION (AQUIFER)	3 GEOLOGIC FORMATIONS OVERLYING AQUIFER	4 MINIMUM NOMINAL CASING DIAMETER INCHES	UPPER DRILLHOLE				9 LOWER DRILLHOLE MINIMUM WELL DIAMETER	10 MAXIMUM NOMINAL PROTECTIVE LINER DIAMETER	11 CONSTRUCTION CONDITIONS	
				UPPER ENLARGED DRILLHOLE		REGULAR DRILLHOLE					
				5 MINIMUM DIAMETER	6 MINIMUM DEPTH	7 MINIMUM DIAMETER	8 BOTTOM ELEVATION				
d.	Limestone (See Note 3)	Unconsolidated materials, mainly sand or gravel, to depth of at least 40' to a radius of 1/2 mile. No record of sink holes, test holes, quarries or abandoned wells in above area.	6"	Casing diameter plus 4" if one is constructed with cable tool drilling. See construction conditions. Casing diameter plus 2" with rotary drilling.	None required with cable tool drilling. To rock with rotary drilling.	6" with cable tool drilling. Not applicable with rotary drilling.	See construction conditions.	6"	2" less than the lower drillhole diameter.	The protective well casing pipe shall be firmly seated in the rock formation. When an upper enlarged drillhole is constructed with cable tool equipment, the annular space shall be filled with clay slurry or cement grout placed in an approved manner. See Note 2 below. With rotary drilling, the upper enlarged drillhole shall be maintained at full diameter with drilling mud or with temporary well casing and the annular space shall be permanently sealed with drilling mud or cement grout, except that only cement grout shall be used when the upper enlarged drillhole is constructed more than 2' into the limestone. The vertical zone of contamination must be sealed off. See Note 1 below. Also see Appendix.	d,e Protective well casing pipe placed in an upper enlarged drillhole only 2" greater in diameter than the nominal well casing pipe diameter, as is only permissible with rotary-air drilling, shall be assembled with welded joints and sealed in place with drilling mud or cement grout placed in the annular space by a suitable pump from the bottom of the casing upward.
e.	Limestone (See Note 3)	Clay or similar material or such materials with some sand and gravel zones to depth of at least 40' to a radius of 1/2 mile. No record of sink holes, test holes, quarries or abandoned wells in above area.	6"	Casing diameter plus 4" with cable tool drilling. Casing diameter plus 2" with rotary drilling. See construction conditions.	To the bottom of the clay or to the 20' depth, whichever is the lesser, with cable tool drilling. To rock with rotary drilling.	6" with cable tool drilling. Not applicable with rotary drilling.	See construction conditions.	6"	2" less than the lower drillhole diameter.	The protective well casing pipe shall be firmly seated in the rock formation. With cable tool drilling, the upper enlarged drillhole shall be kept open by temporary well casing, when necessary and shall be kept 1/3 filled with clay slurry throughout driving of the protective well casing. The balance of the annular space shall be filled with clay slurry or cement grout applied in an approved manner. Construction conditions for drilling with rotary equipment are the same as above for line d. The vertical zone of contamination must be sealed off. See Note 1 below. Also see Appendix.	d,e,f Protective liner pipe shall be assembled with welded joints, placed concentrically within the drillhole and sealed in place with cement grout placed by a suitable pump or other approved method from the bottom of the liner pipe upward.
f.	Limestone (See Note 3)	Unconsolidated materials for depth less than 40' within a radius of 1/2 mile. No record of sink holes, test holes, quarries or abandoned wells in above area.	6"	Casing diameter plus 4" with cable tool drilling. Casing diameter plus 2" with rotary drilling. See construction conditions.	10' into unrecrived rock below 30'.	Not applicable.		6"	2" less than the lower drillhole diameter.	The upper enlarged drillhole through caving formations above the rock shall be kept open by temporary well casing with cable tool drilling and with such casing or drilling mud with rotary drilling. If the formation over the rock is clay or material which will similarly stand open, with rotary drilling the drill cuttings preferably shall be removed by drilling mud but use of air will be permitted for such geologic formations. The annular space shall be permanently filled with cement grout. The vertical zone of contamination must be sealed off. See Note 1 below. Also see Appendix.	f The upper enlarged drillhole diameter need be only 2" greater than the nominal well casing pipe diameter when the well casing pipe is assembled with welded joints and the cement grout is placed in the annular space by a suitable pump or other approved pressure method from the bottom of the casing upward.

NOTE 1. Casing only to rock under conditions of column 3, lines d & e and to the depth indicated in column 6, line f for condition of column 3, line f, is only acceptable as a minimum when it is adequate to seal off the vertical zone of contamination. Greater depth of protective casing is required in areas where well histories show that the vertical zone of contamination extends to a greater depth.

NOTE 2. Some drillers construct an enlarged upper drillhole with cable tool equipment by choice under geologic conditions of column 3, line d, to facilitate use of longer lengths of pipe.

NOTE 3. Although the carbonate rocks in this state are primarily dolomites, the term limestone has been given to them in the well construction specifications because it is the common term given to them by drillers.

TABLE I
DRILLED TYPE WELL REQUIREMENTS

1 TYPE	2 NATURE OF WATER BEARING FORMATION (AQUIFER)	3 GEOLOGIC FORMATION OVERLYING AQUIFER	4 MINIMUM NOMINAL CASING DIAMETER INCHES	5 UPPER DRILLHOLE				9 LOWER DRILLHOLE MINIMUM WELL DIAMETER	10 MAXIMUM NOMINAL PROTECTIVE LINER DIAMETER	11 CONSTRUCTION CONDITIONS	
				5 UPPER ENLARGED DRILLHOLE		6 REGULAR DRILLHOLE					
				5 MINIMUM DIAMETER	6 MINIMUM DEPTH	7 MINIMUM DIAMETER	8 BOTTOM ELEVATION				
g.	Shale (See Note 3)	Unconsolidated materials, mainly sand or gravel, to depth of at least 40' to a radius of 1/2 mile.	6"	Casing diameter plus 4" if one is constructed with cable tool drilling. See construction conditions. Casing diameter plus 2" with rotary drilling.	None required with cable tool drilling. To shale with rotary drilling.	6" with cable tool drilling. Not applicable with rotary drilling.	See construction conditions.	6"	2" less than the lower drillhole diameter.	The protective well casing pipe shall be firmly seated in the shale formation. When an upper enlarged drillhole is constructed with cable tool equipment, the annular space shall be filled with clay slurry or cement grout placed in an approved manner. See Note 2 below. With rotary drilling, the upper enlarged drillhole shall be maintained at full diameter with drilling mud or temporary well casing and the annular space shall be permanently sealed with drilling mud or cement grout, except that only cement grout shall be used when the upper enlarged drillhole is constructed more than 2' into the shale. The vertical zone of contamination must be sealed off. See Note 1 below. Also see Appendix.	g,h Protective well casing pipe placed in an upper enlarged drillhole only 2" greater in diameter than the nominal well casing pipe diameter, as is only permissible with rotary-air drilling, shall be assembled with welded joints and sealed in place with drilling mud or cement grout placed in the annular space by a suitable pump from the bottom of the casing upward.
h.	Shale (See Note 3)	Clay or similar material or such materials with some sand and gravel zones to a depth of at least 40 feet to a radius of 1/2 mile.	6"	Casing diameter plus 4" with cable tool drilling. Casing diameter plus 2" with rotary drilling. See construction conditions.	To the bottom of the clay or whichever is the lesser, with cable tool drilling. To shale with rotary drilling.	6" with cable tool drilling. Not applicable with rotary drilling.	See construction conditions.	6"	2" less than the lower drillhole diameter.	The protective well casing pipe shall be firmly seated in the shale formation. With cable tool drilling, the upper enlarged drillhole shall be kept open with temporary well casing, when necessary, and shall be kept 1/3 filled with clay slurry throughout the driving of the protective casing. The balance of the annular space shall be filled with clay slurry or cement grout applied in an approved manner. Construction conditions for drilling with rotary equipment are the same as above for line g. The vertical zone of contamination must be sealed off. See Note 1 below. Also see Appendix.	g,h,i Protective liner pipe shall be assembled with welded joints, placed concentrically within the drillhole and sealed in place with cement grout placed by a suitable pump or other approved method from the bottom of the liner pipe upward.
i.	Shale (See Note 3)	Unconsolidated materials or limestone with or without unconsolidated formations above to a depth of less than 40' within a radius of 1/2 mile. No record of abandoned wells or test holes within the area.	6"	Casing diameter plus 4" with cable tool drilling. Casing diameter plus 2" with rotary drilling. See construction conditions.	40 feet	Not applicable	See construction conditions.	6"	2" less than the lower drillhole diameter.	The upper enlarged drillhole through caving formations above the rock shall be kept open by temporary well casing with cable tool drilling and by such casing or drilling mud with rotary drilling. If the unconsolidated formation over the rock is clay or material which will similarly stand open, with rotary drilling the drill cuttings preferably shall be removed by mud but use of air will be permitted for such geologic formations. The annular space surrounding the well casing shall be permanently filled with cement grout. The vertical zone of contamination must be sealed off. See Note 1 below. Also see Appendix.	i The upper enlarged drillhole diameter need be only 2" greater than the nominal well casing pipe diameter when the well casing pipe is assembled with welded joints and the cement grout is placed in the annular space by a suitable pump or other approved pressure method from the bottom of the casing upward.

NOTE 1. Casing only to shale under conditions of column 3, lines g & h and to the depth indicated in column 6, line i, for condition of column 3, line i, is only acceptable as a minimum when adequate to seal off the vertical zone of contamination. Greater depth of protective casing is required in areas where well histories show that the vertical zone of contamination extends to a greater depth.

NOTE 2. Some drillers construct an enlarged upper drillhole with cable tool drilling equipment by choice under geologic conditions of column 3, line g, to facilitate use of longer lengths of pipe.

NOTE 3. Wells normally shall not be developed into a shale formation. Such constructions are limited primarily to "Maquoketa" shale where the limestone is missing or very thin but only when the shale is known to be firm enough so that the drillhole will remain open and the water therefrom is not turbid. These wells may occur along the western edge of the Niagara dolomite extending from Door County to the Illinois border, at Blue Mound, at the Platteville Mound and in the Sinsinawa area in Grant County. Shale wells under similar geologic conditions in other areas of the state where overlying rock is missing or thin will also be acceptable.

TABLE I
DRILLED TYPE WELL REQUIREMENTS

1 TYPE	2 NATURE OF WATER BEARING FORMATION (AQUIFER)	3 GEOLOGIC FORMATIONS OVERLYING AQUIFER	4 MINIMUM NOMINAL CASING DIAMETER INCHES	5 UPPER DRILLHOLE				9 LOWER DRILLHOLE MINIMUM WELL DIAMETER	10 MAXIMUM NOMINAL PROTECTIVE LINER DIAMETER	11 CONSTRUCTION CONDITIONS	
				5 UPPER ENLARGED DRILLHOLE		6 REGULAR DRILLHOLE					
				5 MINIMUM DIAMETER	6 MINIMUM DEPTH	7 MINIMUM DIAMETER	8 BOTTOM ELEVATION				
m.	Sandstone	Unconsolidated materials mainly sand and gravel to a depth of 25' or more.	6"	Casing diameter plus 4" if one is constructed with cable tool drilling. See construction conditions. Casing diameter plus 2" with rotary drilling.	None required with cable tool. Into firm sandstone with rotary drilling.	6" with cable tool drilling. Not applicable with rotary drilling.	See construction conditions.	6"	2" less than the lower drillhole diameter.	The protective well casing pipe shall be firmly seated in the rock formation. When an upper enlarged drillhole is constructed with cable tool equipment, the annular space shall be filled with clay slurry or cement grout placed in an approved manner. See Note 2 below. With rotary drilling, the upper enlarged drillhole shall be maintained at full diameter with drilling mud or with temporary well casing and the annular space shall be permanently sealed with drilling mud or cement grout, except that only cement grout shall be used when the upper enlarged drillhole is constructed more than 2' into the sandstone. The vertical zone of contamination must be sealed off. See Note 1 below. Also see Appendix.	m,n Protective well casing pipe placed in an upper enlarged drillhole only 2" greater in diameter than the nominal well casing pipe diameter, as is only permissible with rotary-air drilling, shall be assembled with welded joints and sealed in place with drilling mud or cement grout placed in the annular space by a suitable pump from the bottom of the casing upward.
n.	Sandstone	Clay or similar material or such material with some sand and gravel zones to depth of 25' or more.	6"	Casing diameter plus 4" with cable tool drilling. Casing diameter plus 2" with rotary drilling. See construction conditions.	To the bottom of the clay or to the 20' depth whichever is the lesser, with cable tool drilling. Into firm sandstone with rotary drilling.	6" with cable tool drilling. Not applicable with rotary drilling.	See construction conditions.	6"	2" less than the lower drillhole diameter.	The protective well casing pipe shall be firmly seated in the rock formation. With cable tool drilling, the upper enlarged drillhole shall be kept open by temporary well casing, when necessary and shall be kept 1/3 filled with clay slurry throughout the driving of the protective casing. The balance of the annular space shall be filled with clay slurry or cement grout applied in an approved manner. Construction conditions for drilling with rotary equipment are the same as above for line m. The vertical zone of contamination must be sealed off. See Note 1 below. Also see Appendix.	m,n,o Protective liner pipe shall be assembled with welded joints, placed concentrically within the drillhole and sealed in place with cement grout placed by a suitable pump or other approved method from the bottom of the liner pipe upward.
o.	Sandstone	Any material except limestone to a depth of less than 25'.	6"	Casing diameter plus 4" with cable tool drilling. Casing diameter plus 2" with rotary drilling. See construction conditions.	Into firm sandstone or to the 30' depth whichever is greater.	Not applicable.		6"	2" less than the lower drillhole diameter.	The upper enlarged drillhole through casing formations above the rock shall be kept open by temporary well casing with cable tool drilling and by such casing or drilling mud with rotary drilling. If the formation over the rock is clay or material which will similarly stand open, with rotary drilling the drill cuttings preferably shall be removed by mud but use of air will be permitted for such geologic formations. The annular space surrounding the protective well casing shall be permanently filled with cement grout. The vertical zone of contamination must be sealed off. See Note 1 below. Also see Appendix.	o The upper enlarged drillhole diameter need be only 2" greater than the nominal well casing pipe diameter when the well casing pipe is assembled with welded joints and the cement grout is placed in the annular space by a suitable pump or other approved pressure method from the bottom of the casing upward.

NOTE 1. Casing only to the depth indicated in column 6, lines m, n & o, for conditions of column 3, lines m, n & o, is only acceptable as a minimum when it is adequate to seal off the vertical zone of contamination. Greater depth of protective casing is required in areas where well histories show that the vertical zone of contamination extends to a greater depth.

NOTE 2. Some drillers construct enlarged upper drillholes to a depth of several feet with cable tool equipment by choice under geologic conditions of column 3, line m, to facilitate use of longer lengths of pipe.

TABLE I
DRILLED TYPE WELL REQUIREMENTS

1 TYPE	2 NATURE OF WATER BEARING FORMATION (AQUIFER)	3 GEOLOGIC FORMATIONS OVERLYING AQUIFER	4 MINIMUM NOMINAL CASING DIAMETER INCHES	5 UPPER DRILLHOLE				9 LOWER DRILLHOLE MINIMUM WELL DIAMETER	10 MAXIMUM NOMINAL PROTECTIVE LINER DIAMETER	11 CONSTRUCTION CONDITIONS	
				6 UPPER ENLARGED DRILLHOLE		7 REGULAR DRILLHOLE					
				5 MINIMUM DIAMETER	6 MINIMUM LENGTH	7 MINIMUM DIAMETER	8 BOTTOM ELEVATION				
j.	Granite or Quartzite (See Note 1)	Unconsolidated materials mainly sand or gravel, to depth of at least 40' to a radius of 1/2 mile.	6"	Casing diameter plus 4" if one is constructed with cable tool drilling. See construction conditions. Casing diameter plus 2" with rotary drilling.	None required with cable tool. To rock with rotary drilling.	6" with cable tool drilling. Not applicable with rotary drilling.	See construction conditions.	6"	2" less than the lower drillhole diameter.	The protective well casing pipe shall be firmly seated in the rock formation. When an enlarged upper drillhole is constructed with cable tool equipment, the annular space shall be filled with clay slurry or cement grout placed in an approved manner. See Note 2 below. With rotary drilling equipment, the upper enlarged drillhole shall be maintained at full diameter with drilling mud or temporary well casing and the annular space shall be permanently sealed with drilling mud or cement grout, except that only cement grout shall be used when the upper enlarged drillhole is constructed more than 2' into the granite. The vertical zone of contamination must be sealed off. See Note 3 below. Also see Appendix.	j,k Protective well casing pipe placed in an upper enlarged drillhole only 2" greater in diameter than the nominal well casing pipe diameter, as is only permissible with rotary-air drilling, shall be assembled with welded joints and sealed in place with drilling mud or cement grout placed in the annular space by a suitable pump from the bottom of the casing upward.
k.	Granite or Quartzite (See Note 1)	Clay or similar material or such materials with some sand and gravel zones to a depth of at least 40' to a radius of 1/2 mile.	6"	Casing diameter plus 4" with cable tool drilling. Casing diameter plus 2" with rotary drilling. See construction conditions.	To the bottom of the clay or to the 40' depth whichever is the lesser with cable tool drilling. To rock with rotary drilling.	6" with cable tool drilling. Not applicable with rotary drilling.	See construction conditions.	6"	2" less than the lower drillhole diameter.	The protective well casing pipe shall be firmly seated into the rock formation. With cable tool drilling the upper enlarged drillhole shall be kept open with temporary well casing, when necessary, and shall be kept 1/3 filled with clay slurry throughout the driving of the protective casing. The balance of the annular space shall be filled with clay slurry or cement grout applied in an approved manner. Construction conditions for drilling with rotary equipment are the same as above for line j. The vertical zone of contamination must be sealed off. See Note 3 below. Also see Appendix.	j,k,l Protective liner pipe shall be assembled with welded joints, placed concentrically within the drillhole and sealed in place with cement grout placed by a suitable pump or other approved method from the bottom of the liner pipe upward.
l.	Granite or Quartzite (See Note 1)	Unconsolidated materials for depth less than 40' within a radius of 1/2 mile.	6"	Casing diameter plus 4" with cable tool drilling. Casing diameter plus 2" with rotary drilling. See construction conditions.	40' See construction conditions for exceptions.	Not applicable.		6"	2" less than the lower drillhole diameter.	Normally 40' of pipe is required to seal off the vertical zone of contamination. An attempt shall be made to obtain water below 40' and at least to a depth of 75' even though water in quantity may be encountered during drilling at a depth above 40'. Should an adequate water producing zone not be encountered below 40' and down to a depth of 75' or lower, consideration may be given by the Department to permit production of the water above 40'. Department approval is required for such well. Other construction conditions are the same as for line f. The vertical zone of contamination must be sealed off. See Note 3 below. Also see Appendix.	l The upper enlarged drillhole diameter need be only 2" greater than the nominal well casing pipe diameter when the well casing pipe is assembled with welded joints and the cement grout is placed in the annular space by a suitable pump or other approved pressure method from the bottom of the casing upward.

NOTE 1. Crystalline rocks are classed as granite because they are commonly referred to as granite by drillers regardless of their true rock type. This includes trap rock.

NOTE 2. Some drillers construct an enlarged upper drillhole with cable tool equipment by choice under geologic conditions of column 3, line j, to facilitate use of longer lengths of pipe.

NOTE 3. Casing only to rock under conditions of column 3, lines j & k and to the depth indicated in column 6, line l, for condition of column 3, line l, is only acceptable as a minimum when it is adequate to seal off the vertical zone of contamination. Greater depth of protective casing is required in areas where well histories show that the vertical zone of contamination extends to a greater depth.

NR 112.085 Well casing pipe. The protective well casing pipe shall be of steel or thermoplastic material complying with the requirements and restrictions of this section.

(1) STEEL CASING PIPE. (a) *Dimensions and weights.* The protective well casing pipe materials shall be steel pipe having the nominal diameters and the weights as specified in table 2, except that for wells for potable school water systems and high capacity water systems, the minimum wall thickness for 8-inch, 10-inch, and 12-inch diameter pipe shall be 0.322-inch, 0.365-inch, and 0.375-inch, respectively, and for non-potable systems pipe of any diameter used shall have an adequate wall thickness to make the well structurally sound.

TABLE 2
MINIMUM
CASING PIPE AND COUPLING
WEIGHTS AND DIMENSIONS

Size in Inches	Wgt. Lbs. Per Ft.		Pipe				Couplings	
	Threads & Coupling	Plain End	Thickness in Inches	Diameter - Inches		Threads Per Inch	External Diameter Inches	Length in Inches
1	1.70	1.68	.133	1.315	1.049	11-1/2	1.576	2-5/8
1-1/4	2.30	2.27	.140	1.660	1.380	11-1/2	1.900	2-3/4
1-1/2	2.75	2.72	.145	1.900	1.610	11-1/2	2.200	2-3/4
2	3.75	3.65	.154	2.375	2.067	11-1/2	2.750	2-7/8
2-1/2	5.90	5.79	.203	2.875	2.469	8	3.250	2-15/16
3	7.70	7.58	.216	3.500	3.068	8	4.000	4-1/16
3-1/2	9.25	9.11	.226	4.000	3.548	8	4.625	4-3/16
4	11.00	10.79	.237	4.500	4.026	8	5.200	4-5/16
5	15.00	14.62	.258	5.563	5.047	8	6.296	4-1/2
6	19.45	18.97	.280	6.625	6.065	8	7.390	4-11/16
6-5/8 OD	20.00	19.49	.288	6.625	6.049	8 R	7.390	7-1/4
7 OD	23.00	22.63	.317	7.000	6.366	8 R	7.657	7-1/4
8	25.55	24.70	.277	8.625	8.071	8	9.625	5-1/16
10	35.75	34.25	.307	10.750	10.136	8	11.750	5-9/16
12	45.45	43.77	.330	12.750	12.090	8	14.000	5-15/16
14 OD	57.00	54.57	.375	14.000	13.250	8	15.000	6-3/8
16 OD	65.30	62.58	.375	16.000	15.250	8	17.000	6-3/4
18 OD	73.00	70.59	.375	18.000	17.250	8	19.000	7-1/8
20 OD	81.00	78.60	.375	20.000	19.250	8	21.000	7-5/8
22 OD		114.81	.500	22.000	21.000			
24 OD		125.49	.500	24.000	23.000			
26 OD		136.17	.500	26.000	25.000			
28 OD		146.85	.500	28.000	27.000			
30 OD		157.53	.500	30.000	29.000			
32 OD		168.21	.500	32.000	31.000			
34 OD		178.89	.500	34.000	33.000			
36 OD		189.57	.500	36.000	35.000			

R = Round Threads

(b) *Assembly.* Well casing pipe shall be assembled watertight by means of joints welded in accordance with the standard welding procedure specifications of the department of industry, labor and human relations, Ind 53.53 (3), Wis. Adm. Code or by correctly mated, recessed type couplings as used on drill pipe, line pipe or reamed and drifted pipe and having weights and being threaded as indicated in table 2.

(c) *Pipe installation.* Well casing pipe shall be driven or installed so that no injury to the pipe results which may affect the quality of the water supply.

(d) *Pipe specifications.* 1. No used pipe may be installed as the protective well casing in the permanent construction of a well or for other potable water supply use, except that the well constructor may reuse pipe withdrawn immediately from a newly constructed unsuccessful well or from a new well where the department requests the well constructor to reconstruct or replace it, provided the pipe has suffered no physical damage. The pipe used as the permanent protective well casing either in initial well construction, as a liner subsequent to the initial construction or for other potable water supply purpose shall be new pipe meeting any of the following standards, but further subject to freedom from injurious defects as listed in subd. 4.:

- a. ASTM A-53;
- b. ASTM A-106;
- c. ASTM A-120;
- d. ASTM A-589;
- e. API 5A;
- f. API 5AX;
- g. API 5L;
- h. API 5LX;
- i. AWWA C 200;
- j. The standard outlined in subd. 3.

2. Except as provided in subd. 3., each length of pipe 2 inches in diameter or greater shall be legibly marked in conformance with the ASTM, API or AWWA marking specifications for the particular pipe standard showing, where respectively required, the manufacturer's name or trade mark; ASTM or AWWA marking or API monogram; standard; size in inches; weight in pounds per foot; whether seamless or welded and, if welded, type of weld; grade; and length in feet and tenths of feet.

3. It is permissible to use new weldable steel pipe having nominal diameters of Table 2 for 16 inch pipe or less and tested to a minimum hydrostatic pressure of 1200 p.s.i. and which is otherwise determined to be equivalent to pipe meeting the ASTM A-120 specification in accordance with the following procedures:

a. Each length of such pipe shall be pressure tested and shall be marked or labeled with the test pressure and a code mark acceptable to and registered with the department and the secretary of state, which shall act as certification that the pipe is equivalent to the ASTM A-120 specification.

b. Any entity which proposes to test its pipe in accordance with this subsection shall provide to the department a proposed testing program and procedure which shall be approved by the department prior to the initiation of the testing program.

c. As a part of the surveillance of the testing procedure, at a maximum of 8 unannounced times annually as determined by the department, an independent testing laboratory, contracted for by the entity supplying

the pipe and acceptable to the department, shall inspect the testing procedure of the entity and perform hydrostatic tests on at least 10 lengths of pipe in the entity's stock which has been tested and marked. In addition, the department may require that up to 10 lengths of pipe selected in any year by the department from stock of randomly selected well drillers shall be tested by an independent laboratory in Wisconsin acceptable to the department and contracted for by the entity supplying the pipe. No more than one length of pipe may be selected for testing during any visit. The transportation of the pipe to the laboratory and replacement of the driller's stock and the cost of the testing shall be the responsibility of the entity supplying the pipe. The results of the surveillance inspection and testing by the laboratories shall be reported to the department by the laboratories.

4. All pipe intended for water well construction or other potable water supply use within this state shall be subject to random examination by the department which may require any defective length of pipe or lots having more than 5% of pipe with lengths less than 5 feet to be rejected and returned to the manufacturer or supplier. Defective lengths shall include, but not be limited to:

- a. Pipe with girth welded joints;
- b. Pipe with welded patches;
- c. Pipe not conforming to the marking requirements of subd. 2. or 3.;
- d. Pipe with injurious defects, such as:
 - 1) Cracks;
 - 2) Open welds;
 - 3) Partial or incomplete welds;
 - 4) Open seams;
 - 5) Laminations in pipe wall which exceed 12½% of wall thickness;
 - 6) Slivers which exceed 12½% of wall thickness.

5. The listed ASTM, API and AWWA references are available for inspection at the offices of the department of natural resources, the secretary of state and the revisor of statutes and may be obtained for personal use from the American Society for Testing and Materials, 1916 Race Street, Philadelphia, Pennsylvania 19103, the American Petroleum Institute, Division of Production, 300 Conigan Tower Building, Dallas, Texas 75201 and from the American Water Works Association, 6666 West Quincy, Denver, Colorado 80235.

(2) THERMOPLASTIC CASING PIPE. (a) *Pipe and material specifications.* 1. The thermoplastic well casing pipe and couplings shall be new polyvinyl chloride (PVC) material produced to and meeting the current ASTM F-480 standard except that the impact resistance requirements specified in the current ASTM D 2241 standard may be substituted for the impact resistance requirements specified in ASTM F 480. PVC material shall conform to cell classification 12454-B or 12454-C as designated by markings of PVC 1120 or 1220. The material shall be formulated to include a filler material to resist ultra-violet degradation. The

solvent cement shall conform to the ASTM D-2564 standard. No used or reclaimed materials may be used. Either integral bell pipe or one piece couplings shall be used.

2. The pipe shall have a standard dimension ratio (SDR) of 21, 17, or 13.5.

3. The nominal casing size shall be at least 5 inches.

4. The well casing pipe, couplings, cement, primer and other components shall be evaluated and approved for use as well casing in potable water supplies by the National Sanitation Foundation (NSF) Testing Laboratories, Inc., P.O. Box 1468, Ann Arbor, Michigan 48106 or an equivalent laboratory approved by the department. Such laboratory must approve the materials as being acceptable for use as well casing for potable water supplies. Approvals of alternate laboratories will be based on the demonstration of unbiased, reliable and appropriate testing methods at least as stringent as NSF methods.

5. The well casing pipe and couplings shall be marked in accordance with the current ASTM F-480 specification and this section. The pipe shall be marked at least every 5 feet showing the nominal size; standard dimension ratio; type of material; the designation 1120 or 1220; the wording — “well casing” — followed by impact classification; designation “ASTM F-480” including year of issue of the standard with which the well casing pipe complies; manufacturer’s name or trademark; manufacturer’s code for resin manufacture, lot number and date of manufacture; and the NSF-WC designation or other approved laboratory’s seal or mark. Couplings shall be marked with all of the above information except the standard dimension ratio, the wording “well casing”, and manufacturer’s code for resin, lot and date.

(b) *Storage and inspection.* 1. The pipe and couplings may not be stored by the driller in direct sunlight for periods exceeding 3 months. It is recommended that pipe and coupling inventories be rotated or utilized to minimize exposure to ultraviolet radiation.

2. The pipe shall be stored in such a manner as to prevent deformation, sagging or bending.

3. Prior to use, the pipe and couplings shall be inspected for cuts, deformations, gouges, deep scratches, damaged ends and other imperfections. Any pipe or couplings having such defects shall be rejected.

4. Pipe bells and couplings shall be manufactured to close tolerances to ensure an interference fit at the joint. Should a joint not have an interference fit allowing the dry pipe to enter the socket between $\frac{1}{2}$ and $\frac{3}{8}$ of the socket depth when inserted by hand, the pipe or coupling shall be rejected.

(c) *Assembly.* Joining techniques including procedures for cutting, cleaning of joints, use of primers, application of cement, assembly and hardening of solvent cement joints shall be in accordance with this section and the manufacturer’s recommendations.

1. ‘Cutting’. The installer shall use a fine tooth handsaw with little or no set or a plastic pipe cutter equipped with extra-wide rollers and thin cutting wheels for cutting the pipe. Pipe ends shall be cut square using a

miter box when sawed. Standard steel pipe or tubing cutters may not be used for cutting plastic pipe.

2. 'Cleaning'. The installer shall clean all dirt, dust, and moisture from pipe ends and couplings. The installer may use only chemical or mechanical cleaners which are suitable for the particular plastic material being used. All burrs shall be removed.

3. 'Primer'. The installer shall use a primer to prepare the pipe and coupling surfaces in order to form a continuous bond when cemented.

4. 'Cement application'. The joint shall be completed immediately following application of the solvent cement. A solvent cement shall be used which provides sufficient open time for making good joints, but which also cures rapidly to initial set. At temperatures below 32°F a cement formulated for use below 32°F shall be used. The installer shall apply a moderate and even coat of cement to the inside of the pipe bell or coupling to cover the length of the joining surface only. The installer shall then quickly apply an even coat of cement to the outside of the pipe to a length equal to the depth of the pipe coupling socket.

5. The installer shall make the joint as quickly as possible after application of the cement, and before it dries; reapply cement before assembling if the cement dries partially; insert the pipe into the coupling socket, turning the pipe at least ¼ turn before it seats to insure even distribution of cement; make sure that the pipe is inserted to the full depth of the coupling socket, and remove excess solvent cement from the exterior of the joint with a clean, dry cloth.

6. A newly assembled joint may not be moved until after sufficient time has elapsed to adequately cure the joint to withstand the installation stresses without movement or damage. It is recommended that all joints be allowed to cure at least 15 minutes if the ambient temperature is 60°F or above, at least ½ hour if between 40 and 60°F, and at least one hour if the ambient temperature is below 40°F before the pipe is moved and installed. Cure times may be reduced when temperatures are above the bottom of the above ranges. In no case shall cure times be less than ½ of the times recommended above. Cure times shall be increased by 50% when the relative humidity is over 60%. No pins, screws or fasteners may be installed in the joint.

7. For threaded couplings used for pitless adapters, only approved lubricant specifically intended for use with PVC pipe is acceptable. A threaded joint shall be tightened by no more than one full turn using a strap wrench.

8. When a well screen is used, it shall be a telescoping type screen. The casing must be pulled back to expose the screen. An approved packer shall be used to seal the space between the screen and the casing. A small diameter drill stem or rod bearing on the screen bottom plate may be used to place the screen.

(d) *Installation requirements.* 1. The well casing pipe may not be driven, pushed or forced into the formation. When pulling back a casing to expose a screen, the force applied may not exceed the casing weight.

2. The casing shall be set in an outer drillhole full of drilling mud or a temporary casing which shall in either case be at least 4 inches larger

than the nominal pipe size. A permanent tag bearing the message "plastic well casing" shall be attached to the top of the well casing.

3. Thermoplastic well casing pipe may be used only for wells developed in unconsolidated formations and constructed in accordance with lines a, b and c of table 1 and lines b and c of table 3.

4. No drilling tools such as drillbits or stabilizers shall be placed in the casing nor shall any drilling or reconstruction occur after placement of the casing in the well. This restriction does not preclude the installation or replacement of telescoping screens.

5. Thermoplastic well casing pipe shall be used only for wells where the annular space is sealed with drilling mud or clay slurry. Cement grout may not be used. The thermoplastic well casing shall be set in the drilling mud of a drillhole constructed with rotary-mud equipment or within a temporary casing driven the entire depth of the permanent casing if constructed with other equipment.

6. Any pitless subsurface connection to the thermoplastic well casing shall be made in accordance with s. NR 112.14 (1) (b) or (2) (b) and (8). The portion of the well casing above a pitless adapter may be either steel or PVC well casing pipe meeting the requirements of this section.

Note: See NR 112.14 (8).

7. Threaded pipe is not permitted. Threaded couplings may only be used for installation of pitless adapters after placement of the casing.

8. If the portion of the well casing pipe which extends above the frost line is thermoplastic material, the upper terminus of the well shall be contained in a well house or in a capped oversized steel casing which extends from above the top of the thermoplastic well casing to a depth of below the frost level.

(e) The listed ASTM standards are available for inspection at the offices of the department of natural resources, the secretary of state and the revisor of statutes and may be obtained for personal use from the American Society for Testing and Materials, 1916 Race Street, Philadelphia, Pennsylvania 19103.

History: Cr. (intro.), (1) (a) to (d) renum. from NR 112.08 (2) (a) to (d) and am. (1) (d) 5., cr. (2), Register, October, 1982, No. 322, eff. 11-1-82; reprinted to correct error in (2) (c) 7., Register, January, 1983, No. 325.

NR 112.09 Bored type well design and construction. (1) **GENERAL.** The general construction requirements are the same as NR 112.08 (1).

(2) **SPECIFIC.** Through the vertical zone of contamination the construction of bored type wells shall conform to the specifications for drilled type wells prescribed by NR 112.08 (2) [112.085 (1)]. They shall also conform to the following additional requirements:

(a) The minimum diameter of the casing pipe shall be 6 inches.

(b) The top of the well casing pipe shall terminate at least 8 inches above the ground grade.

(c) The curbing below the vertical zone of contamination shall be properly cured concrete pipe or equal. In such case the joints shall be the

tongue and groove type. Plain end or bell and spigot pipe shall not be used.

(d) The minimum inside diameter of well curbing shall be 8 inches.

(Note: The vertical zone of contamination is the same as for a drilled sand or sand and gravel type well. See table 1, NR 112.08 (2) and figure 2.)

History: Cr. Register, June, 1975, No. 234, eff. 10-1-75.

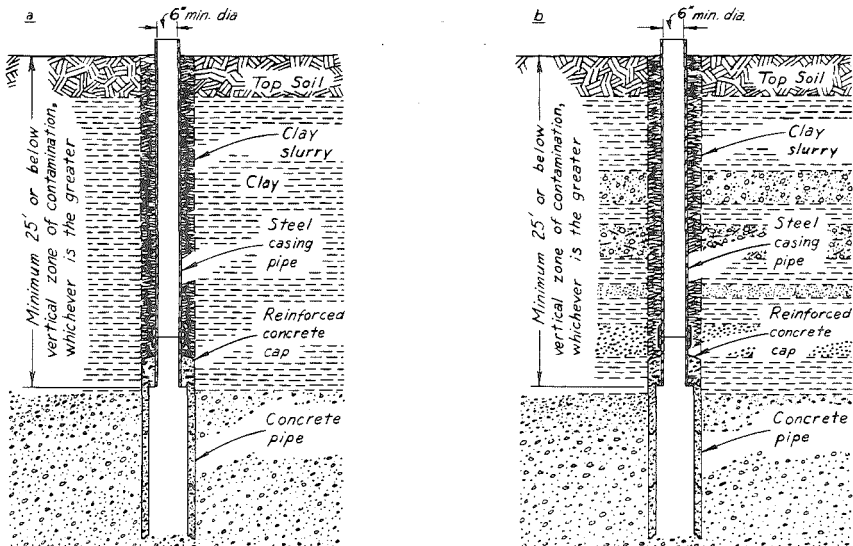

Figure 2. Bored Type Well Construction. See NR 112.09.

NR 112.10 Driven point type well design and construction. (1)

GENERAL. The general construction requirements are the same as NR 112.08 (1).

(2) SPECIFIC. Through the vertical zone of contamination the depth of the unperforated pipe of a driven point well shall conform to the specifications of NR 112.08 (2) for drilled sand or sand and gravel type wells. Driven point wells shall also conform to the following additional requirements:

(a) The diameter of the driven point well shall be selected with the expected depth of ground water in mind so as to make a pump installation practical.

(b) The depth of a driven point well shall be sufficient to prevent breaking suction when pumping the well at a rate of 50% greater than the capacity of the permanent pump.

(Note: See figure 3.)

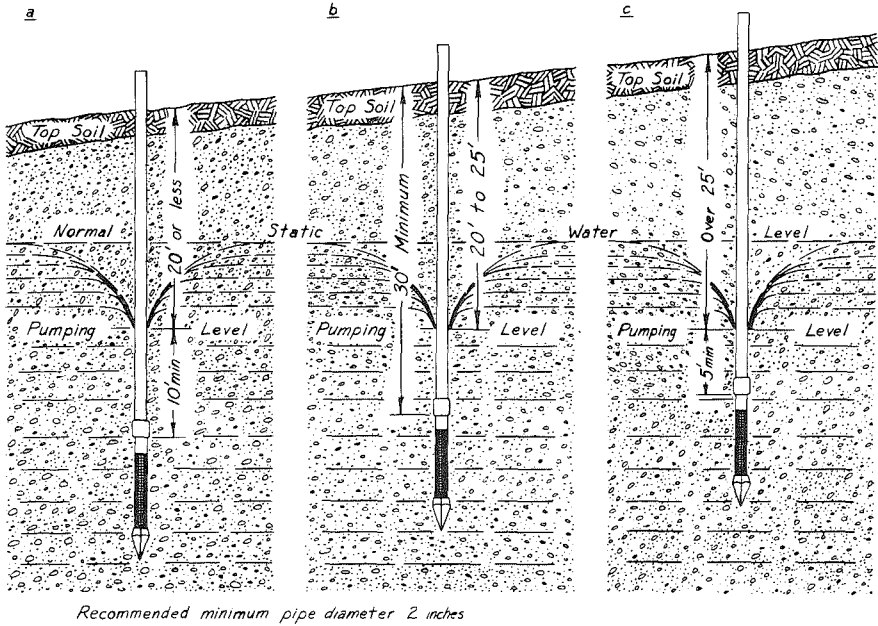

Figure 3. Construction of Driven-Point Wells in Sand and Gravel. See Table 1, a and NR 112.10.

(c) Protection against freezing shall be accomplished by means of an enclosing casing pipe. So-called "frost-pits" curbed with stones, brick, tile, wood and the like are prohibited. (Note: See figure 4.)

History: Cr. Register, June, 1975, No. 234, eff. 10-1-75.

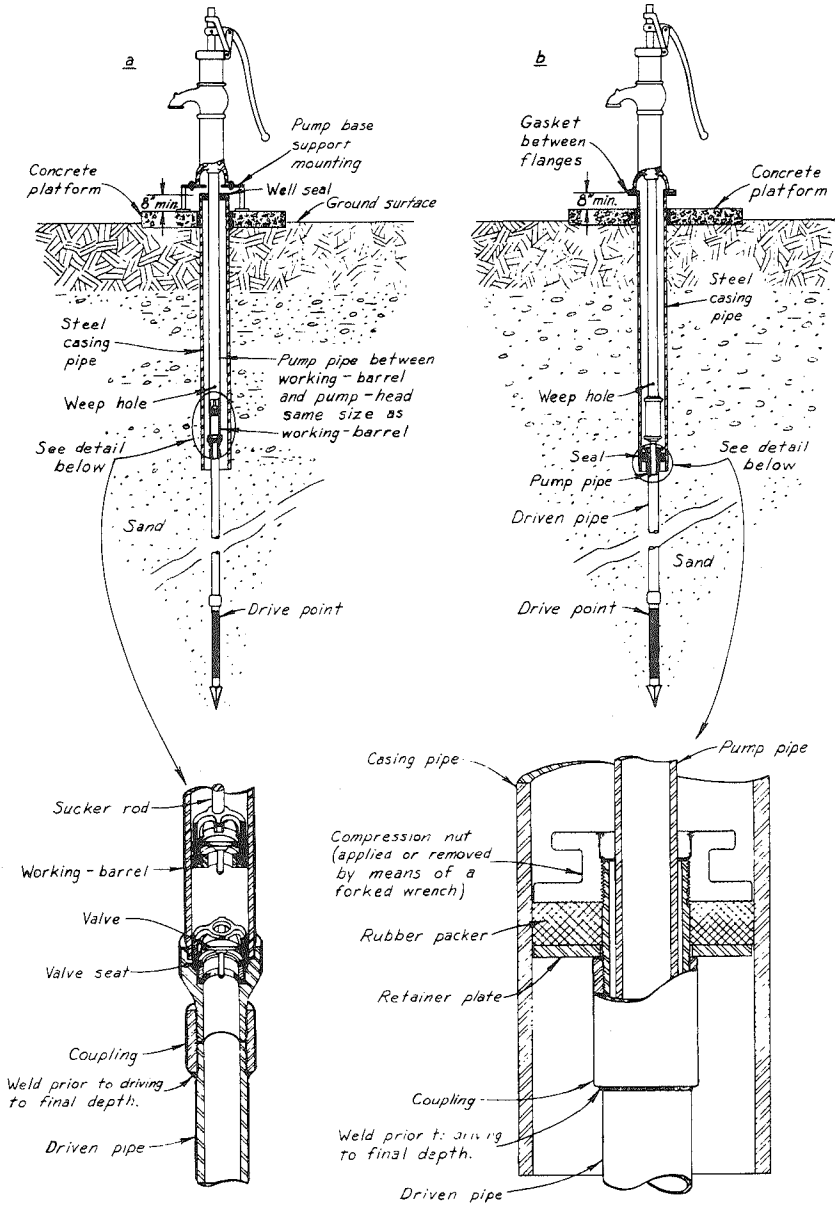

Figure 4. Driven-Point Well Construction. Illustration (b) shows suitable method of returning frost drain water to well when impervious soil is present. See NR 112.10

NR 112.11 Dug type well design and construction. (1) **GENERAL.** The general construction requirements are the same as NR 112.08 (1).

(2) **SPECIFIC.** (a) *Curbing wall.* The curbing wall of every dug type well shall be substantial and watertight to a depth of at least 2 feet below the vertical zone of contamination, which zone is the same as for a drilled sand or sand and gravel type well, but in no case less than 25 feet below the established ground surface at the well. The curbing through the intake area shall be of adequate strength to withstand any external pressure to which it may be subjected and must be seated firmly enough to prevent settling.

(b) *Concrete wall.* The wall shall be circular and at least 6 inches thick with concrete so placed as to be free from voids. The concrete mixture shall conform with the provisions of NR 112.19 (1). Vertical and horizontal reinforcing with $\frac{3}{8}$ -inch rods on 12-inch centers shall be provided. Rods shall lap 12 inches but such lap shall not occur at construction joints. If possible, the wall shall be poured in one operation but in no case shall there be a construction joint within 10 feet of the surface. Construction joints shall be left rough and shall be washed and brushed with neat cement grout before pouring of concrete is continued. (Note: See figures 5 (a) and (b).)

(c) *Metal wall.* A metal curbing wall of steel shall be at least three-sixteenths of an inch thick, assembled with welded joints and in any case, the wall shall be sufficiently thick and so reinforced as to resist any external pressure to which it may be subjected.

(d) *Casing pipe reduction.* In lieu of extending well curbing of full dug well diameter to the surface, a standard weight new steel pipe at least 6 inches in diameter and meeting the requirements of table 2 and NR 112.085 (1) (d) may be used. This pipe shall be firmly seated in a reinforced concrete slab which shall be mounted on the full diameter curbing. Such slab shall be located so that the top is at least 25 feet below the established ground surface at the well or at least 2 feet below the vertical zone of contamination, whichever is the greater. (Note: See figures 5 (c) and (d).)

(e) *Curbing installation.* In caving soil formation, the curbing shall be constructed at the surface and carried down by excavating from the interior. If wood forms are used on the exterior of the wall, they shall be removed before the wall is lowered. Use of exterior wood forms below the ground surface is prohibited. Metal forms may be left in place.

(f) *Annular opening.* The opening between the face of the excavation and curbing or casing through the vertical zone of contamination shall be filled with clean clay slurry or equal.

(g) *Upper terminal.* Except when a dug well is constructed in accordance with par. (d) of this subsection and approval has been obtained from the department in conformance with NR 112.14 for construction of a well pit or subsurface pump room adjoining a building basement, the curbing shall be extended at least 8 inches above the established ground surface, and the ground graded up around same to a height of 6 inches above the ground so as to conduct all surface water away from the well.

(h) *Dug well cover.* The cover of a well curbed according to par. (b) or (c) of this subsection shall be made of substantial reinforced watertight concrete at least 5 inches thick and of sufficient diameter to overlap the wall or curb by at least 2 inches. The cover shall be free from joints. A pump installation access sleeve comprising a section of steel protective well casing pipe conforming to NR 112.085 (1) (a) and (d) shall be installed in the cover at the time of pouring the concrete in fabricating the cover and shall terminate at least 8 inches above the top of the cover. The top of the cover shall be sloped to drain away from the access sleeve. A manhole, if installed, shall be provided with a 4-inch high metal curb which shall be equipped with an overlapping cover, the sides of which extend downward at least 1½ inches. A tight joint shall be provided between the top of the wall and the cover, using a plastic sealing compound. The manhole cover shall be locked or bolted in place in such manner as to be safe and to prevent entrance of water. (Note: See NR 112.17(1).)

(i) *Equipment location.* No pumping equipment or appurtenances requiring access to the interior of the well for maintenance or repair operations shall be installed in the well. (Note: For acceptable type of pump installations, see figure 5.)

History: Cr. Register, June, 1975, No. 234, eff. 10-1-75; am. (2) (d) and (h), Register, October, 1982, No. 322, eff. 11-1-82.

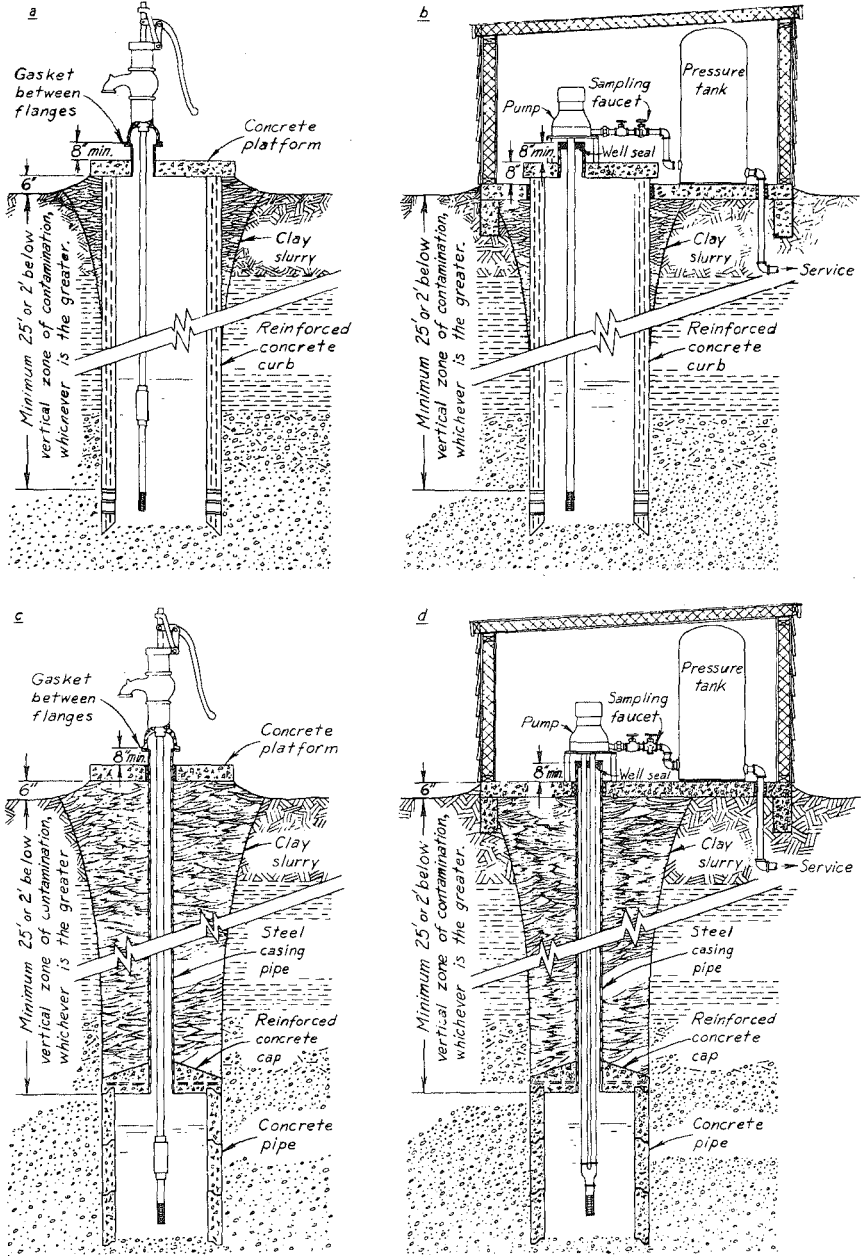

Figure 5. Sanitary Construction of Dug Type Wells and Acceptable Methods of Installation of Pumps. See NR 112.11.

NR 112.12 Reconstructing dug type wells. (1) **GENERAL.** The general construction requirements are the same as NR 112.08 (1).

(2) **SPECIFIC.** A drilled type well may be constructed through an existing dug type well in accordance with the following procedures:

(a) *Preparation for deepening.* Any sediment or debris in the bottom of the dug well shall be removed. The bottom shall be disinfected by distributing a chlorine solution over the bottom or mixing such solution with water in the well. A concentration of 200 parts per million of chlorine should be attained for disinfection.

(b) *Applicability to drilled type construction.* Deepening construction done by drilling methods shall conform to applicable provisions of NR 112.08 (2). (Note: See figure 6.)

(c) *Protection.* Existing "dug and drilled" type wells shall be effectively protected against entrance of surface and near-surface water by extending the casing pipe of the drilled part of the well to an elevation of at least 8 inches above the established ground surface and filling the dug part of the well with clay slurry or equally impermeable material, removing the top 7 to 8 feet of curbing in the process to effect a good soil to soil bond.

History: Cr. Register, June, 1975, No. 234, eff. 10-1-75.

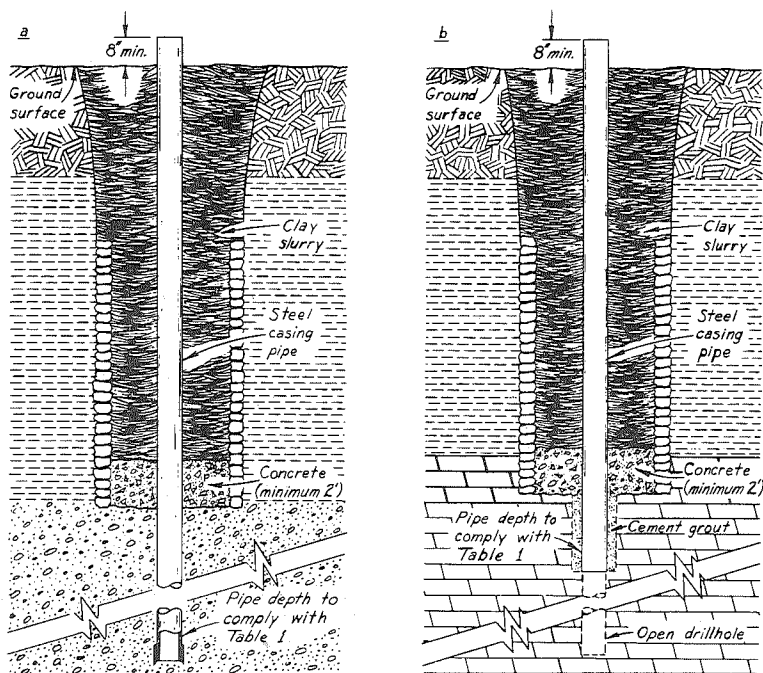

Figure 6. Drilled Well Constructed in Existing Dug Type Well. See NR 112.12.

NR 112.13 Springs. Because of the great variation in springs from the standpoint of sources, locations, surrounding land uses, and elevations in relation to surrounding areas, each spring being considered as a possible source of drinking water must be evaluated on its own merits for possible acceptance. Requests for spring evaluations shall be made to the central office of the department. Evaluations shall be based on the following criteria:

(1) **LOCATION.** (a) The area laterally from the spring for a distance of at least 50 feet, below the spring for a distance of at least 30 feet and above the spring to the crest of the slope shall not be used as pasture, crop land or for human habitation.

(b) The spring outlet shall be located at least 2 feet above the regional flood water level.

(c) The spring shall be derived from a source having sufficient overburden so that if a drilled well were constructed at a distance of 100 feet horizontally and upgrade from the spring to produce water from the spring source, the well construction could comply with the minimum well casing pipe depth specifications of table 1, NR 112.08(2) of this chapter.

(2) **CONSTRUCTION.** To be acceptable as a source of water for drinking and food processing, in addition to meeting the above criteria, a spring shall be protected by the following minimum construction:

(a) Provisions shall be made to divert surface water runoff away from the spring.

(b) A reinforced poured concrete box structure having the following minimum features shall be constructed to house the spring outlet:

1. Five-inch thick walls.
2. Five-inch thick roof.
3. Twenty-four square feet cross-section, with a minimum width of 4 feet.
4. Twenty-inch diameter or 20-inch square access opening in the roof with a 4-inch thick curbing wall extending 8 inches above the roof.
5. Overlapping, tight-fitting, shoebox-type cover with 4-inch skirted sides, constructed out of welded sheet steel.
6. Two 6-inch diameter, steel-pipe sleeves in the roof, having minimum diameters of 4 inches and extending at least 8 inches above the roof for entrance of pump suction pipe and either a pump discharge pipe or a service pipe from a pressure tank.
7. Steel overflow pipe.
8. Discharge pipe from pump or supply pipe from pressure tank extending through the roof and down into the spring, from which point the discharge pipe or supply pipe shall extend below grade to buildings served.
9. Approved type sanitary well seals to seal openings between pipe sleeves and suction pipe and pump discharge or tank service pipe.

(c) An insulated housing shall be provided above the spring box for frost protection for the pump and for the pressure tank, when installed at the spring. (Note: See figure 7.)

History: Cr. Register, June, 1975, No. 234, eff. 10-1-75.

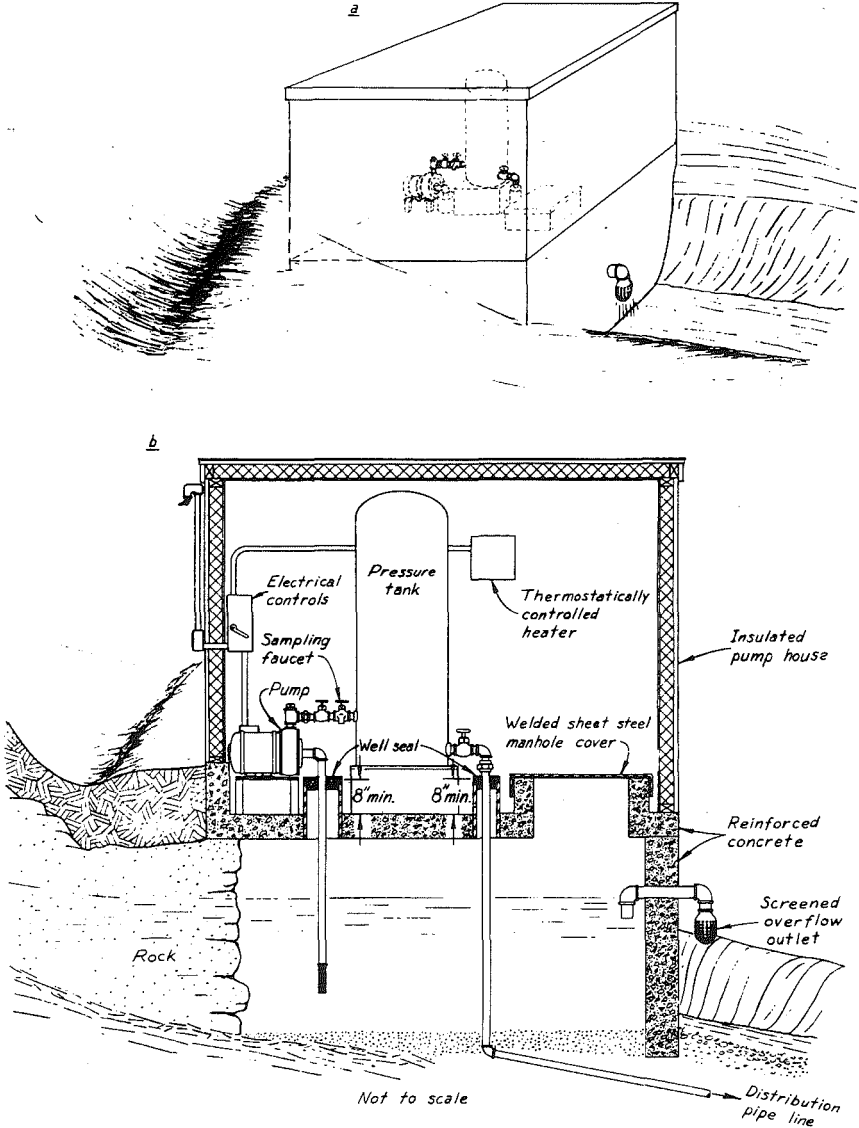

Figure 7. Spring House.

NR 112.14 Surface protection. (1) WATER SUPPLIES EXCEPT THOSE FOR LESS THAN 4 FAMILIES, SCHOOLS, SEWAGE TREATMENT PLANTS AND HIGH CAPACITY INSTALLATIONS. All wells governed by this chapter, except those serving residential units housing a total of not more than 3 families, and school water systems, high capacity water systems and sewage treatment plant water systems shall be provided surface protection in accordance with the provisions of this subsection.

(a) The watertight protective well casing pipe shall extend to a point at least 8 inches above the established ground surface unless a permit for construction of a separate well pit or a subsurface pumphouse adjoining a basement has been obtained from the department; except that, within a flood plain, the top of a well shall terminate at least 2 feet above the regional flood elevation and no pit or subsurface pumphouse shall be constructed. (Note: See section NR 112.07 (4).)

(b) Any pitless subsurface pipe connection to such a well shall be made with approved threaded fittings and shall be made above ground water level. The piping for such a connection shall be kept under gauge pressure. For the purpose of this chapter, approved threaded fittings include pitless adapters and pitless receiver tanks designed to be connected to the well casing pipe and approved by the department. The design criteria on which approvals are based involve materials of construction, wall thickness of pipe, wall thickness of other component parts, dimension of shortest cross-section of welds, method of fabrication and method of connection to the well casing.

(c) On off-set installations in basements, the pump impeller or cylinder shall be located preferably at an elevation above the ground surface or at least at an elevation not subject to flooding and in any case at least 2 feet above the basement floor. Any buried suction pipe shall be enclosed in a pressure conduit. Pressure conduits may terminate at the end of the horizontal line entering a basement if the elevation of the pipe entrance is 2 feet or more above the basement floor and the basement is in active use and not subject to flooding. Pressure conduit shall meet the minimum pipe specifications of the state plumbing code, s. H 62.19, Wis. Adm. Code. A shallow well pump discharge line shall discharge through a seal-cross fitting before entering the pressure tank.

(2) WATER SUPPLIES FOR A MAXIMUM TOTAL OF 3 FAMILIES IN RESIDENTIAL UNITS. Water supplies for residential units housing a total of not more than 3 families, shall be provided surface protection in accordance with the provisions of this subsection.

(a) Watertight protective well casing pipe shall extend to a point at least 8 inches above the established ground surface unless a permit for construction of a separate well pit or sub-surface pumphouse adjoining a basement is obtained from the department, except that, within a flood plain, the top of the well shall terminate at least 2 feet above the regional flood elevation and no pit or subsurface pumphouse may be constructed. (Note: See s. NR 112.14 (1).)

(b) Any pitless subsurface connection to such a well shall be made with approved threaded fittings as defined in NR 112.14 (1) (b) or by means of joints welded in accordance with the standard welding procedure specifications of the department of industry, labor and human relations, Wis. Adm. Code s. Ind. 53.53 (3), and the connection shall be

made above ground water level. In addition, the pump location shall not be subject to flooding. Weld-on pitless adapter units shall be approved units.

(c) On off-set installations in basements, the pump impeller or cylinder shall be located preferably at an elevation above the ground surface or at least at an elevation not subject to flooding and in any case at least 2 feet above the basement floor. Any buried suction pipe shall be enclosed in a conduit. It is recommended that the conduit be pressurized. Conduits may terminate at the end of the horizontal line entering a basement if the elevation of the pipe entrance is 2 feet or more above the basement floor and the basement is in active use and not subject to flooding. Nonpressure conduit shall be at least 4 inches in diameter and conform to s. NR 112.085. Pressure conduit shall meet the minimum pipe specifications of the state plumbing code, s. H 62.19. A shallow well pump discharge line shall discharge through a seal-cross fitting before entering the pressure tank.

(d) Restriction on the pipe material when pressurized conduits are used with pitless adapters and the restrictions on the terminal of such pipe in a basement are the same as under sub. (1).

(3) ALL SCHOOL WATER SYSTEMS, HIGH CAPACITY WATER SYSTEMS AND SEWAGE TREATMENT PLANT WATER SYSTEMS. The watertight protective well casing pipe of wells for all school water systems, high capacity water systems and sewage treatment plant water systems shall terminate at least 12 inches above the established ground grade at the well except in flood plains where the top of the well shall terminate at least 2 feet above the regional flood elevation; no well pits may be constructed; and, except for sewage treatment plant systems, no subsurface pump piping connections shall be made to the well casing pipe.

(4) PITLESS ADAPTERS AND BURIED SUBMERSIBLE PUMP DISCHARGE LINES. Buried submersible pump discharge lines connected to pitless adapters must be maintained under gauge pressure at all times. Therefore, no check valves shall be placed in the pump discharge line between a pitless adapter and a hydro pneumatic tank or approved comparable type pressure vessel. The check valve shall be located either at the top of the submersible pump, in that portion of the discharge pipe within the well or on the adapter spool of an approved unit.

(5) PIT PERMITS FOR OTHER THAN WELL PITS. Pit structures for the housing of offset pumps, for access to the head of a buried pressure tank or to completely house a pressure tank shall not be constructed without a permit from the department.

(6) APPLICATION FOR PIT AND SUBSURFACE PUMPROOM PERMITS. Permit applications to construct a well pit, pump pit, pressure-tank pit, pressure-tank access pit or subsurface pumproom adjoining a building basement, shall be made to the central office of the department on forms provided by the department. Such permits may be granted if the construction will be made in conformance with minimum specifications of the department. (Note: See subs. (1), (2) and (4).)

(a) Separate well pits, pump pits, pressure-tank pits and pressure-tank access pits shall conform to the following minimum specifications:

1. Dimensions:

a. Area. Five square feet of free floor area shall be provided for each square foot of area required for equipment and appurtenances. In no case shall the inside area of a pit be less than 24 square feet.

b. Width. The width of the pit shall be not less than $\frac{2}{3}$ of the length.

c. Height. The height inside shall be at least 6 feet, but not less than 6 inches higher than any equipment installed therein.

d. Walls, floor and roof thicknesses. The wall thickness shall be at least 6 inches, the floor thickness shall be at least 4 inches and the roof thickness shall be at least 5 inches.

2. Construction:

a. Material. The pit shall be constructed of poured concrete thoroughly puddled in place. The concrete shall be prepared according to specifications of NR 112.19 or by use of clean water and washed sand and gravel or crushed rock in the following proportions: 1 part cement, 2 parts sand and 3 parts gravel. The water-cement ratio should not exceed 0.75 to 1.

b. Watertight juncture. The junction of walls, floor and roof shall be watertight. Every conduit or similar connection with the pit shall be watertight.

c. Reinforcement. The deck or pit roof and walls of the pit structure shall be adequately reinforced to insure strength and durability.

3. Elevation of pit roof. The pit roof or deck shall be above the ground surface.

4. Manhole opening:

a. Placement. The pit shall be fitted with a manhole opening. It shall be located directly over the well, unless the well casing itself extends through the cover, or a capped section of pipe at least equal in diameter and thickness to the well casing is cast into the pit roof directly over the well.

b. Size. The manhole opening shall be at least 20 inches square or 20 inches in diameter, inside measurement, and in any case shall be sufficiently large to permit entrance or removal of any unit or equipment that must be installed through the manhole.

c. Curbing. The manhole opening shall be provided with a raised curbing at least 4 inches thick, extending at least 4 inches higher than the pit roof.

d. Cover. A substantial watertight, overlapping, tight-fitting, shoe-box type cover with skirted sides at least 3 inches wide shall be provided for the manhole. A welded sheet-steel cover is preferred, but a cover made out of lumber and covered in turn with sheet metal or tin will be acceptable if maintained in a waterproof condition.

e. Exception. A watertight, cast-iron manhole frame and cover with gasket may be substituted for the concrete curbing.

5. Drainage:

a. Gravity type. Where practical, the pit shall be drained by a separate watertight gravity-type drain discharging to the ground surface at a point free from flooding. The drain shall be constructed of cast iron, copper or galvanized steel having a minimum diameter of 2 inches.

b. Watertight sump type. When no gravity-type drain can be installed in conformance with sub. (5) (a) 5a, a watertight sump, having a minimum depth of 18 inches and a minimum cross-section of 18 inches square or minimum diameter of 18 inches, shall be installed.

6. Termination of well casing. In the case of well pits, the casing shall terminate at least 18 inches above the pit floor and be provided with an approved watertight, sanitary well seal with gasket, or an equivalent watertight connection with the pump.

7. Venting:

a. Pit. A well pit, pump pit, pressure-tank pit or pressure-tank access pit shall be vented by use of two 2-inch diameter galvanized steel pipes located in opposite corners, one pipe to extend to within 1 foot of the pit floor and the other to extend only through the pit roof. The upper end of the vent pipes shall terminate with return bends and be screened.

b. Well. Any well vent pipe shall extend to the top of the pit and terminate with a return bend with a screened outlet.

8. Pump installation. The free space around the well casing shall be such that the upper casing terminal is readily accessible for installation, adjustment or removal of an expanding type or equivalent well seal and for the removal of the pump or piping. The pump powerhead shall be mounted on an elevated subbase of concrete or metal. When pumps are installed with a flanged connection with the casing, all openings in the pump base shall be sealed.

(b) Subsurface pumphouses adjoining basements shall conform to the following minimum specifications:

1. General.

a. The dimensions, construction material, watertight juncture, reinforcement, roof elevation, manhole opening, well casing termination and pump installation shall conform to provisions of sub. (5) (a) 1. through (a) 4. inclusive, sub. (5) (a) 6. and 8.

b. The floor elevation shall be at least 1 foot higher than the basement floor if the basement is constructed with masonry other than reinforced poured concrete.

2. Drainage:

a. The pumphouse floor may drain to the basement floor if the basement in turn is adequately drained.

b. If the basement is not adequately drained, a partition wall at least 1 foot high shall be constructed in the entranceway from the basement and separate drainage facilities shall be provided conforming to the pit drainage requirements of sub. (5) (a) 5.

(7) **PITLESS ADAPTER CONNECTIONS TO STEEL WELL CASINGS.** (a) *Threaded joints.* When the threaded end of a well casing is not conveniently terminated for installation of a pitless adapter, threads shall be provided at the top of a cut-off well casing for attachment of the pitless adapter, including pitless receiver tanks, by one of the following methods:

1. Cutting threads with a die.
2. Fitting and welding a full-length standard recessed coupling to the top of the casing, after reaming out threads to a point at least $\frac{1}{3}$ the length of the coupling, including the recess, for adapters with male threads.
3. Fitting and welding a full-length standard recessed coupling to the top of the casing, after reaming out threads to a point at least $\frac{1}{3}$ the length of the coupling, including the recess, and installing a steel pipe nipple made from pipe conforming to NR 112.085 (1), and threaded on both ends, for pitless adapters with female threads.

(b) *Weld-on units.* An approved type pitless adapter weld-on unit may only be installed on wells where nonpressure conduit installations with offset pumps are permissible. These are installations for private residences, serving not more than 3 families. (Note: See sub. (2).)

(c) *Well and pipe connection restrictions.* 1. The threaded lower end of a full-length adapter shall not be welded to the cut-off end of a well casing.

2. The threaded ends of a short model, complete adapter shall not be welded to the top of a cut-off well casing nor to the section of riser pipe extending from the unit to a point above the ground grade.

3. Pitless adapters, including pitless receiver tanks, shall not be connected to the well casing by means of a compressible joint.

4. Pitless adapter pipe connectors for attachment of pump piping shall be welded to the full adapters in the factory at the time the adapter is assembled by the manufacturer having approval to fabricate the same in cases of those designs not involving a casting where the connector will be part of the casting. Such pipe connector units may be welded to the well casing pipe in the field only for those installations where weld-on adapter units are permissible. Pipe connectors shall not be attached to well casings with compression joints. (Note: See sub. (2).)

(d) *Welding procedure.* The joining of a coupling to the cut-off well casing or of a weld-on pitless adapter unit or pipe connector to a well casing shall be done in accordance with the standard welding procedure specifications of the department of industry, labor and human relations, Ind 53.53 (3), Wis. Adm. Code. (Note: For adaption of pitless adapters, including pitless receiver tanks, see Figures 8 and 9.)

(8) **PITLESS ADAPTER CONNECTIONS TO THERMOPLASTIC WELL CASINGS.** No welding of steel well casing or a pitless adapter is permitted after steel well casing is attached to thermoplastic well casing. If a weld-on pitless adapter is to be utilized in cases allowed by sub. (2), the adapter shall be welded to the steel portion of the casing pipe before the steel casing is threaded into a thermoplastic coupling. The PVC coupling

shall be threaded onto the steel casing or adapter before it is solvent cemented to the top of the PVC casing.

History: Cr. Register, June, 1975, No. 234, eff. 10-1-75; am. (1) (intro.), renum. (3) thru (6) to be (4) thru (7), cr. (3), Register, April, 1978, No. 268, eff. 5-1-78; am. (1) (c) and (7) (a) 3., r. and recr. (2) (c) and cr. (8), Register, October, 1982, No. 322, eff. 11-1-82; reprinted to correct error in (1) (c), Register, January, 1983, No. 325.

Next page is numbered 261

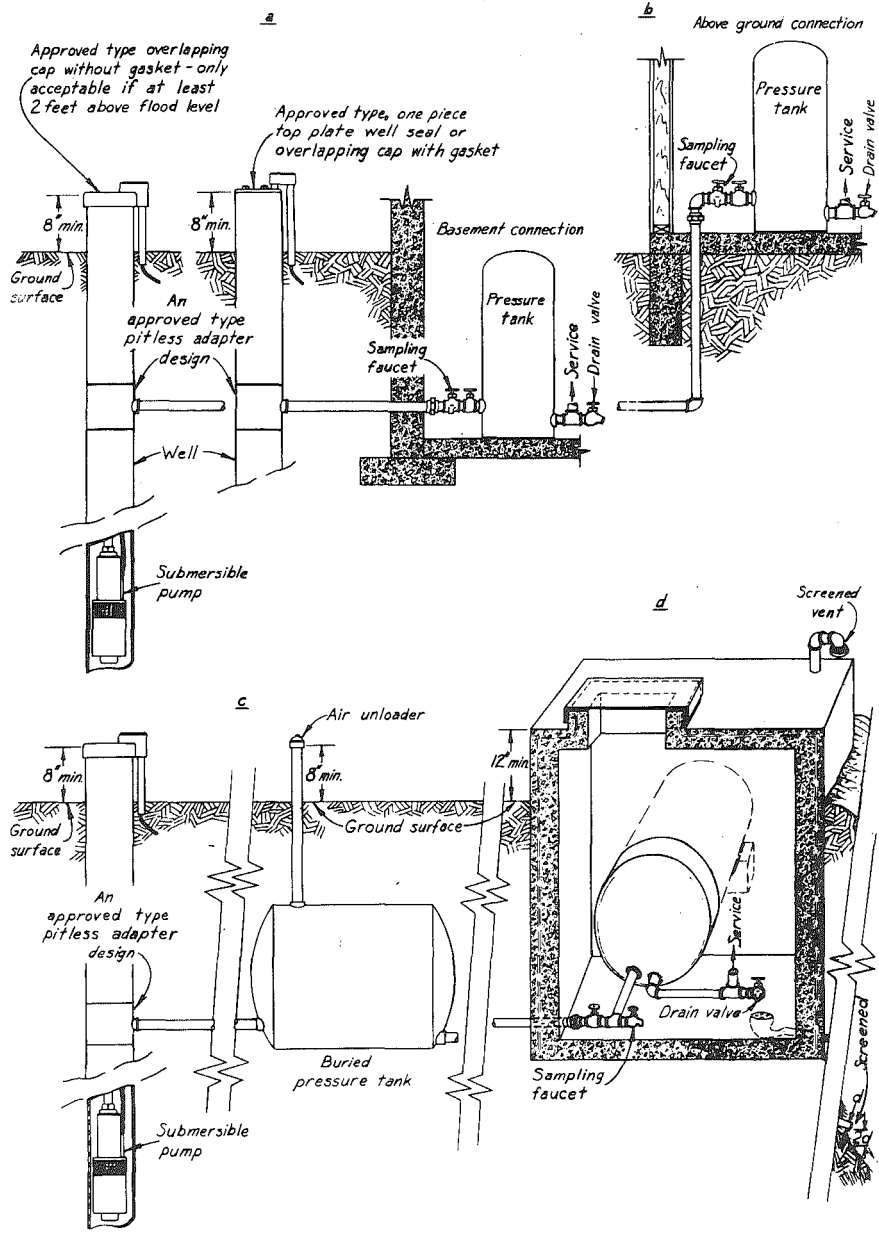

Figure 8. Adaption of Pitless Adapter Unit for Pump Installation.

NR 112.15 Miscellaneous well construction and pump installation requirements. (1) **WELL ALIGNMENT.** The deviation of the center line of a drilled or bored type well from plumb per 100 feet of depth shall not exceed the following tolerances to the depth of pump setting plus 25%:

Diameter of curb in inches	2 to 6	8 to 10	12 or more
Deviation based on diameter	100%	75%	50%

For well depths less than 100 feet the allowable deviation of the center-line shall be proportional to that allowed per 100 feet.

(2) **CAVING PROTECTION.** When caving or sloughing formations that would interfere with the proper functioning of the well or the pumping equipment are encountered, entrance of foreign material shall be prevented by means of liner pipe, cementing or other approved methods.

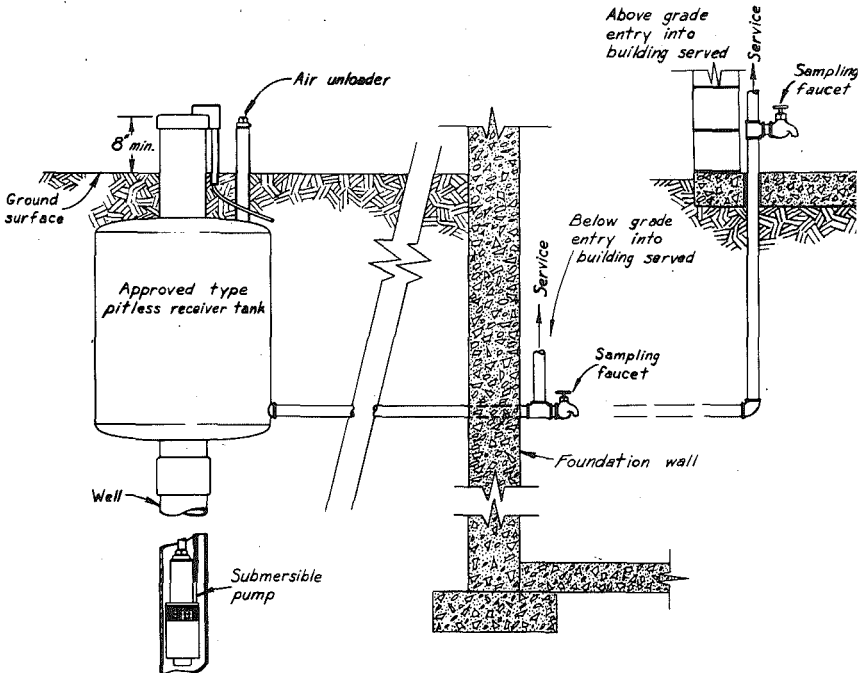

Figure 9. Pitless Receiver Tank Installation.

(3) **FINISHING OPERATIONS.** Upon completing well construction or reconstruction operations or pump installation or repair work requiring removal of the pump or pump piping from the well, the well driller and pump installer shall carry out finishing operations as follows:

(a) *Disinfection.* The well shall be disinfected in the manner prescribed by the department. In addition, the pump installer shall disinfect the pump and discharge piping, the pressure vessel or reservoir.

(b) *Flushing.* The well shall be flushed sufficiently to remove all traces of the disinfectant and to condition the well for use. In addition the pump installer shall flush out the discharge piping and the pressure vessel or reservoir.

(c) *Testing.* The well shall be tested by pumping, except when flowing in excess of requirements, to determine the amount of drawdown and the quantity and stability of the yield within the requirements of NR 112.17 (1) (b), NR 112.03 (2), and NR 112.08 (1) (c), or if in excess thereof, as specified by agreement with the purchaser. With flowing wells, the static water level in a stilling pipe or artesian pressure under static conditions shall be measured as shall be the drawdown or reduction in artesian pressure.

(d) *Sealing.* The well shall be sealed or covered with an approved type well seal or well cap. (Note: See NR 112.17 (1), (2) and (3).)

(4) **BLASTING.** The use of explosives for increasing or recovering yield of any well developed into limestone, shale, granite or quartzite formations, or of any sandstone well in which casings and liners are not grouted or in which the diameter of the drillhole is larger than that of casings or liners above the point of shooting, shall be undertaken only under permit from the department. (Note: See NR 112.16 (3).)

(5) **CHEMICAL CONDITIONING.** (a) *Noncontinuous treatment of wells and pumps.* The use of dry ice, detergents, chlorine, acids, or other chemicals in wells for the purpose of increasing or restoring yield; the use of chemicals, other than chlorine, to combat iron bacteria and sulfur bacteria well infestations and the use of chemicals, other than chlorine, for treatment of pumps for removal of scale or chemical depositions shall be undertaken only under permit from the department. No permit is required for batch chlorination of wells and pumps for disinfection purposes. Chemical treatment of wells requiring a permit shall be done under supervision of a registered well driller or Wisconsin registered professional engineer. Chemical treatment of pumps requiring a permit as established in this subsection shall be done under supervision of a registered pump installer or Wisconsin registered professional engineer. All chemicals other than dry ice or chlorine shall be compounds determined to be acceptable by the department. (Note: See NR 112.16 (3).)

(b) *Continuous water treatment of well and water system.* 1. Potability control. Continuous treatment of water in the well or in the water system for disinfection for potability control shall be undertaken only under a permit obtained by the water supply owner from the department. No permit will be granted for continuous disinfection of a well or water system producing bacteriologically unsafe samples until efforts to construct a new well and reconstruct the well or to reconstruct an

existing well in conformance with this chapter fail to result in a well that will continuously produce bacteriologically safe water.

2. Quality control. Chemical treatment of a well or the total water supply pumped from the well to a point including the pressure tank, reservoir or reservoir and pressure tank when booster pumps are installed, shall be done with chemical compounds and methods approved by the department. Approval of methods of injection of chemicals will be based on adequacy of control of rates of feed against a range of pressures and of the anti-backsiphon provisions of the equipment planned for use.

3. Equipment installation. Installation of treatment equipment requiring plumbing connections to the water system shall be made by a licensed plumber, except that when such equipment is installed prior to the pressure tank, the installation may also be made by a registered pump installer.

(6) OTHER TREATMENT. Nonchemical type mechanical equipment or devices for continuous water treatment shall be installed in the water system only under permit of the department. All nonchemical treatment of water in the system when permitted by the department shall be done with equipment and methods or processes approved by the department. No permit will be granted for the purpose of continuous nonchemical disinfection of a water supply unless efforts to construct a new well and reconstruct the well or to reconstruct an existing well in conformance with the code have failed to result in a well that will continuously produce bacteriologically safe water. Installation of nonchemical treatment equipment requiring plumbing connections to the water system shall be made by a licensed plumber, except that if such equipment is installed prior to the pressure tank, the installation may also be made by a registered pump installer. Approval of the equipment and method or processes is based on their specific ability to perform effectively over a range of conditions and their having adequate controls, and warning devices when necessary, to prevent accidental supplying of polluted water to points of use.

(7) DRILLING AIDS. Materials used as drilling aids such as drilling muds and foam or other aids, shall be compounds or materials approved by the department. Approval of drilling aids is based on toxicity, ground water contaminant possibility and expected effectiveness of the materials.

(8) INJECTION OF FERTILIZERS OR OTHER CHEMICALS FOR AGRICULTURAL PURPOSES. (a) *Potable water supplies or systems.* The injection of fertilizers and pesticides into the discharge pipe or water system is prohibited. Use of such chemicals shall be accomplished by repumping from a steel reservoir tank or a watertight pond. The discharge from the well pump into such reservoir or pond shall have a free fall from a point at least 2 feet above the established reservoir or pond overflow elevation.

(b) *Non-potable water supplies.* 1. Injection of fertilizers. a. Injection of fertilizers into a well or well pump suction pipe is prohibited.

b. The injection of fertilizers should preferably be done in the discharge pipe of a booster pump delivering water from a concrete or steel tank or sealed pond into which the well pump discharges with a free air-break from a point at least 2 discharge pipe diameters above the over-

flow level of the tank or pond, rather than into the discharge pipe of a well pump connected directly to the water system.

c. Injection of fertilizer into the well pump discharge pipe is acceptable, providing it is done with an approved positive displacement type of chemical feed pump at a point following a barometric pipe loop extending at least 30 feet above the highest part of the irrigation system; or a reduced pressure backflow preventer made to and meeting AWWA C506-78 or ASSE 1013 standards; or an underwriters laboratories (UL) approved check valve and preferably a double UL check valve installed in the well pump discharge pipe at the well site. The chemical feed pump shall be shut off at least 5 minutes prior to shutting off of the well pump so as to purge the chemical from the water system.

2. Injection of pesticides. a. The injection of pesticides into a well or well pump suction is prohibited.

b. The injection of pesticides into a water system should preferably be done in the discharge pipe of a booster pump delivering water from a concrete or steel tank or sealed pond into which the well pump discharges with a free air-break from a point at least 2 discharge pipe diameters above the overflow level of the tank or pond.

c. Injection of pesticides into the well pump discharge pipe is prohibited, unless the injection is done with an approved positive displacement type of chemical feed pump at a point following a barometric pipe loop extending to a minimum height of 30 feet above the highest point in the irrigation system or an approved reduced pressure backflow preventer made to and meeting AWWA C506-78 or ASSE 1013 standards, installed in the well pump discharge pipe at the well site but subject to the following conditions:

1) That the department of natural resources shall be notified by the owner of an irrigation system of the installation of a reduced pressure backflow preventer in such system.

2) The backflow preventer shall be installed above flood level and the location shall be accessible for testing, inspection and maintenance.

3) The reduced pressure backflow preventer shall not be bypassed or made inoperative nor shall it be removed from an irrigation system in which pesticides continue to be injected into the pump discharge pipe.

4) An annual testing of the reduced pressure backflow preventer shall be conducted with a differential pressure gauge testing method for reduced pressure backflow preventers by the local plumbing inspector or a person certified by the state department of health and social services, and the owner of the system shall supply a report of the test results to the department before each irrigation season.

5) Pesticide application and use done in compliance with this section must also conform to rules concerning application and use of pesticides contained in section Ag 29.10, Wis. Adm. Code.

3. Standards and tests. a. Copies of the above mentioned ASTM, ASSE and UL standards are available for inspection at the office of the department of natural resources, the secretary of state, or the office of the revisor of statutes, and respective copies may be obtained for per-

sonal use from the American Society of Testing and Materials, 1916 Race Street, Philadelphia, Pennsylvania 19103; the American Society of Sanitary Engineers, 960 Illumination Building, Cleveland, Ohio 44113 and Underwriters Laboratories, Inc., 207 East Ohio Street, Chicago, Illinois 60611.

b. Lists of approved reduced pressure backflow preventers, check valves and positive displacement feed pumps are available for inspection at the offices of the department of natural resources.

c. Certification as a tester may be obtained from the Wisconsin Department of Health and Social Services, Washington Square Building, 1414 E. Washington Avenue, Madison, Wisconsin following successful completion of one of the training courses provided by the University of Wisconsin Extension, Madison, Wisconsin or the University of Southern California School of Engineering, University Park, Los Angeles, California 90007.

History: Cr. Register, June, 1975, No. 234, eff. 10-1-75; cr. (8), Register, April, 1978, No. 268, eff. 5-1-78; am. (8) (b), Register, April, 1980, No. 292, eff. 5-1-80; am. (8) (b) 1. c., Register, August, 1980, No. 296, eff. 9-1-80.

NR 112.16 Samples and reports. (1) **WATER SAMPLES.** Upon completion of the well construction, except those not intended as a source of water supply for drinking or food processing purposes, the well driller shall collect a water sample from the well, by use of a pump, for bacteriological analysis. Likewise, upon completion of the installation of pumping equipment and disinfection and flushing of the well and water system, except those not intended as a source of water supply for drinking or food processing purposes, the pump installer shall collect a sample from the well for bacteriological analysis. Exceptions to these procedures will be permitted when the well driller also installs the pump, in which case submission of the required sample upon completion of the pump installation will be considered satisfactory compliance. Where unforeseeable contamination is encountered, the initial construction of a well will be considered complete if the construction conforms to provisions of this chapter. The water samples shall be submitted either to the state laboratory of hygiene or to an independent laboratory certified under the state laboratory certification program to do bacteriological examination of water; provided that such certified laboratory will file the water sample data sheet and a copy of the water sample analysis report with the department within 20 days following completion of the analysis.

(2) **WELL CONSTRUCTION REPORTS TO DEPARTMENT.** Within 20 days after completing the construction or reconstruction of a well the constructor thereof shall submit a construction report to the department upon a form prescribed and furnished by the department.

(3) **WELL CONDITIONING REPORT TO DEPARTMENT.** Within 20 days after completing any well blasting or chemical treatment operation the well driller, pump installer or other supervisor shall submit a complete report as to methods used and the results achieved for cases covered by the section. (Note: See NR 112.15 (4) and (5) (a).)

(4) **REPORTS TO OWNERS.** The well driller and pump installer shall supply the owner or his agent with a copy of the laboratory analyses report for the sample submitted to the laboratory at completion of their respec-

tive work. The well driller shall also supply to the owner or his agent a copy of the well construction report at the time the report is made to the department.

History: Cr. Register, June, 1975, No. 234, eff. 10-1-75; am. (1), Register, April, 1978, No. 268, eff. 5-1-78.

NR 112.17 Pump installation and construction. (1) **GENERAL.** The installation of every pump shall be so planned and carried out so that the pump will be:

(a) Installed in such manner that the pump and its surroundings can be kept in a sanitary condition.

(b) Properly sized so as to produce the volume of water necessary to meet the requirement of an adequate water supply. (Note: See NR 112.03 (2).)

(c) Designed to meet the well characteristics, durable in character and installed in such manner that continued operation without priming is assured at the time of installation.

(d) Installed in such manner as to provide adequate protection against contamination of any character from any surface or subsurface source.

(2) **UPPER WELL TERMINAL.** (a) For all low capacity water supplies other than for schools, and sewage treatment plants, the casing pipe of any drilled, bored or driven type well or of a dug well having a casing pipe reduction shall project not less than 8 inches above the permanent established ground surface at the well, or 8 inches above a pump house or building floor or platform installed above such established ground surface unless a permit for a subsurface terminal has been obtained. The well casing pipe shall be sealed or covered with an approved type well seal or cap, except that a nonwatertight cap shall not be used in pit installations. Seals for wells terminating outside of buildings shall have a one-piece top plate. (Note: See NR 112.14 (1) and (2) and (3).)

(b) For all school water systems, high capacity water systems and sewage treatment plant water systems, the casing pipe of any well shall project not less than 12 inches above the permanent established ground surface at the well, or 12 inches above a pump house or building floor or platform installed above such established ground surface. The well casing pipe shall be sealed or covered with an approved type well seal or cap. Seals for wells terminating outside of buildings shall have a one-piece top plate. (Note: See NR 112.14 (3).)

(3) **HAND PUMP.** (a) Every shallow well type hand pump and every deep well type hand pump head, shall be so designed and fabricated that no unprotected opening connecting with the interior of the pump exists. The spout shall be of the closed type. (Note: See NR 112.17 (4).)

(b) A hand pump shall be connected firmly to the well casing pipe by threading in case of small diameter well pipe or by bolting the pump flange to a well casing pipe flange with gasket separation so as to effectively seal the top of the casing, except that when a well is located so that the top is at least 2 feet above flood level, a hand pump may be installed by bolting a structured base with recesses to the casing. (Note: See figures 4 & 5.)

(4) POWER DRIVEN PUMP. (a) *Pump setting.* 1. Any deep well vertical centrifugal pump shall be so mounted on or over the well casing pipe or on a pump foundation or a pump stand as to permit effective sealing of the top of the well. Any power-driven shallow well suction pump, deep-well piston pump or deep-well jet pump located over the well shall be installed in such manner as to permit installation and removal of an approved type seal at the top of the well, such as an approved type unit with expandable rubber gasket.

2. In case the pump unit is not located over the well, and the shallow well pump suction pipe, submersible pump discharge pipe or jet pump piping emerges from the top thereof, an approved type seal with expandable rubber gasket or approved equivalent seal shall be provided between the well casing and the piping. A similar type seal with expandable rubber gasket shall be provided at the terminal of a nonpressure conduit containing suction, submersible or jet pump piping. It is recommended that any buried suction line for an off-set pump installation be enclosed in a pressure conduit.

3. On above-ground pump installations, provided the elevation of the top of the well is at least 2 feet above the regional flood water level at the site and provided the discharge head base of a vertical centrifugal pump will be mounted on a base plate or foundation in such manner as to exclude entrance of insects into the well, the discharge head shall preferably be set on a concrete pump support base with protective well casing pipe projecting at least one inch above the concrete pump support base and into the base of the discharge head or the discharge head shall be installed with its base flange set with gasket onto a pipe flange attached to the top of the protective well casing by threaded or welded joint and with the discharge head flange bolted to the pipe flange. (Note: See sub. (8) and s. NR 112.14 (1), (2) and (3).)

4. If the pump base of a deep well vertical centrifugal pump discharge head is not of a recessed type or if the pump support flange for the pump column is of larger diameter than the protective well casing, the extension of the well casing one inch above the bottom of a pump discharge head subbase also will be considered an effective seal, subject to the same restrictions as stipulated in subparagraph 3. and provided that:

a. The top of the subbase and the bottom of the pump discharge head base are secured together as an integral unit by bolts, and

b. If either the top surface of the subbase or the bottom of the pump discharge head base is not a machined surface, a gasket is provided between the 2 surfaces prior to joining them permanently together.

(b) *Above-ground pumphouse or well house or shelter.* The structure housing a power driven pump shall be constructed having the following minimum features:

1. Reinforced poured-concrete floor with top of the floor at least 4 inches above the established grade.

2. Walk-in door opening outward when the pumphouse is large enough.

3. Trapped floor drain discharging to the ground surface when a door is not installed.

4. Thermostatically controlled electrical heating unit.
5. Removable or hinged roof.
6. Insulated walls and roof.
7. Walls firmly secured to floor.
8. Dimensions and actual details of wall and roof design are optional. The dimensions in table 4, figure 12 are recommendations. (Note: See s. NR 112.14 (2) and figures 12 and 13.)

(c) *Lubrication of vertical centrifugal pumps.* 1. Oil lubricated vertical centrifugal pumps are limited to those cases where they are necessary to provide positive lubrication at deep pump settings but in no case shall they be approved for wells in unconsolidated formations or where the pump operation is expected to lower the water level in the well during pumping to a point less than 5 feet above the bottom of the protective well casing pipe.

2. Normally water lubricated vertical centrifugal pumps are required. For water levels deeper than 50 feet, provision shall be made for prelubricating the column bearings prior to pump startup. The necessity of lubrication during pump backspin when allowed to occur shall be determined and provided if necessary. Water for lubrication of pumps shall be supplied by piping connected to the water pressure system.

(d) *Protection from freezing.* Unless an approved-type above ground discharge unit is installed or the discharge pipe is installed above grade and drains back above grade into the well between pumping cycles, the pump discharge line and accessory equipment installed above grade shall be protected against freezing by insulation of structure and piping and installation of dependable heating facilities, preferably a thermostatically controlled type.

(e) *Pressure tank accessibility.* Hydropneumatic tanks in sizes of 1,000 gallons or greater preferably shall be installed above ground but if buried shall have the head end cradled in a basement wall or in the wall of an access pit constructed to the specifications for well pits. A permit shall be obtained for the construction of the access pit. Such large tanks shall have other additional support cradles. (Note: See NR 112.14 (4) and (5).)

(f) *Installation of meters.* Water meters shall be installed at a point in the pump discharge pipe prior to its connection to the hydropneumatic tank and prior to any branch service line.

TABLE 3
HIGH CAPACITY, SCHOOL AND SEWAGE TREATMENT PLANT
DRILLED WELL REQUIREMENTS - POTABLE WATER SUPPLY

1 Type	2 Nature of Water Bearing Formation (Aquifer)	3 Geologic Formations Overlying Aquifer	4 Minimum Nominal Casing Diameter Inches	Upper Drillhole				9 Lower Drillhole Minimum Well Diameter	10 Maximum Nominal Protective Liner Diameter	11 Construction Conditions
				Upper Enlarged Drillhole		Regular Drillhole				
				5 Minimum Diameter	6 Minimum Depth	7 Minimum Diameter	8 Bottom Elevation			
a.	Sand or gravel	Sand or mixture of sand and gravel; or clay or similar material containing layers of sand and gravel; or clay or similar material to varying depths.	6" See construction conditions.	Well casing pipe outside diameter plus 3" if well casing will be assembled with welded joints; or coupling outside diameter plus 3" if well casing will be assembled with threaded and coupled joints.	60' with cable tool drilling & 60' plus such additional depth necessary to place the desired length of screen, with rotary drilling, unless a gravel-pack is planned, in which case the depth of outer drillhole shall be a minimum of 65' plus the desired screen length in either type of drilling. Exception to this requirement holds for sewage treatment plant wells where the minimum amount of protective well casing pipe shall be 100'. See note 2 below.	6" See construction conditions.	Exception See note 2 below.	6"	Not applicable.	<p>a. The protective well casing pipe normally shall extend to a minimum depth of 65' to a minimum depth of 100' for sewage treatment plant wells or to such greater depth will assure that the well casing will extend to a minimum of 5' below the pumping well level. With cable tool drilling the upper enlarged drillhole shall be kept open with temporary well casing, unless the drillhole will penetrate clay or other material which similarly stand open, and the upper drillhole shall be kept 1/3 filled with clay slurry throughout the driving of permanent well casing. With rotary drilling, the outer drillhole shall be maintained at full diameter with drilling mud. The annular space surrounding the protective well casing to minimum depth of 60 feet normally and to 95 feet in sewage treatment plant wells shall be permanently sealed with cement grout placed by a suitable pump from the bottom of the annular space upward. When an outer pipe is used to maintain the enlarged upper drillhole it shall be pulled back at least 10' but preferably shall be entirely removed immediately following completion of grouting the well. The vertical zone of contamination shall be sealed off. See notes 1 and 2 below.</p> <p>An adequate screen shall be provided. Unless a gravel-pack well is planned, the screen shall be installed in such manner that removal or replacement can be accomplished without adversely affecting the watertight construction of the well. For economic reasons an inner pipe separate from the protective well casing to which the screen would be attached is not required, but it is preferred. Either the placement of the screen to the bottom of the drillhole and jacking back of the casing or the bail-down method will be acceptable for the initial screen placement. When a separate pipe is used to place the screen within the protective casing, the pipe shall have a nominal diameter at least 2" than that of the inside diameter of the protective well casing, in which case the protective well casing shall have a minimum diameter of 8", unless a gravel-pack well construction is planned. With a construction having an inner pipe attached to a screen and a gravel-pack, the inner pipe nominal diameter shall be 4" less than the diameter of the protective casing diameter and the outer drillhole shall have a diameter conforming to requirements of column 5. In either case, the protective well casing pipe shall conform to the pipe standards of NR 112.08(2) (d).</p> <p>In a gravel-pack well construction, the gravel used shall be properly graded, washed and sterilized igneous rock gravel free from foreign material. If filler pipes will be installed they shall not be attached to the protective well casing at an elevation less than 12" above the established ground grade at the well or the floor of a building or pump house or well house. The gravel-pack shall be placed through an adequately sized temporary pipe and the gravel-pack shall not extend to an elevation higher than 62' normally, and 97' in the case of sewage treatment plant wells, below the established ground surface. A minimum of a 2" sand seal shall be placed upon the gravel-pack and the remainder of the annular space shall be filled with cement grout placed by an approved pressure method. There shall normally be placed a minimum of 60' of cement grout. See notes 1 and 2 below.</p>

NOTE 1. Greater depth of casing is required in areas where well histories show that the vertical zone of contamination extends to a greater depth.
NOTE 2. Minimum casing depth for sewage treatment plant wells shall be 100'.

TABLE 3
HIGH CAPACITY AND SCHOOL
DRILLED WELL REQUIREMENTS - NONPOTABLE WATER SUPPLY

1 Type	2 Nature of Water Bearing Formation (Aquifer)	3 Geologic Formations Overlying Aquifer	4 Minimum Nominal Casing Diameter Inches	Upper Drillhole				9 Lower Drillhole Minimum Well Diameter	10 Maximum Nominal Protective Liner Diameter	11 Construction Conditions
				Upper Enlarged Drillhole		Regular Drillhole				
				5 Minimum Diameter	6 Minimum Depth	7 Minimum Diameter	8 Bottom Elevation			
b.	Sand or gravel	Sand or a mixture of sand and gravel.	6" See construction conditions.	None required with cable tool drilling but shall be casing diameter plus 4" if one is constructed. See construction conditions. Casing diameter plus 2" with rotary drilling.	30' with cable tool drilling & 30' plus such additional depth necessary to place the desired length of screen, with rotary drilling, unless a gravel-pack is planned, in which case the depth of outer drillhole shall be a minimum of 35' plus the desired screen length in either type of drilling.	6" See construction conditions.	See construction conditions	6"	Not applicable	bc. The well casing pipe normally shall extend to a minimum depth of 35' or to a greater depth that will assure that the well casing will extend to a minimum of 5' below the pumping water level. With cable tool drilling the upper enlarged drillhole shall be kept open with temporary well casing, unless the drillhole will penetrate clay or other material which will similarly stand open, and the upper drillhole shall be kept 1/3 full with clay slurry throughout the driving of permanent well casing. With rotary drilling the outer drillhole shall be maintained at full diameter with drilling mud. The annular space surrounding the protective well casing to a minimum depth of 30 feet, when is constructed, shall be permanently sealed with clay slurry or cement grout placed suitable pump from the bottom of the annular space upward. When an outer pipe used to maintain the enlarged upper drillhole it shall be pulled back at least 10' but preferably shall be entirely removed immediately following completion of grouting well. See note 1 below. An adequate screen shall be provided. The screen shall be installed in such manner removal or replacement can be accomplished. For economic reasons an inner pipe separate from the protective well casing to which the screen would be attached is not required, but it is preferred. Either the placement of the screen to the bottom of the drillhole and jacking back of the casing or the bail-down method will be acceptable the initial screen placement. When a separate pipe is used to place the screen within well casing, the pipe shall have a nominal diameter at least 2" less than that of the diameter of the well casing, in which case the well casing shall have a minimum diameter of 8", unless a gravel-pack well construction is planned. With a construction having inner pipe attached to a screen and a gravel-pack, the inner pipe nominal diameter shall be 4" less than the diameter of the well casing diameter and the outer drillhole shall have a diameter conforming to requirements of column 5.
c.	Sand and gravel	Sand or mixture of sand and gravel; or clay or similar material containing layers of sand and gravel; or clay or similar material to varying depths.	6" See construction conditions.	None required in sand and gravel with cable tool drilling. Casing diameter plus 4" with cable tool if one drilled in sand and gravel or is required when drilling in clay or similar material. Casing diameter plus 2" with rotary drilling.	30' with cable tool drilling & 30' plus such additional depth necessary to place the desired length of screen, with rotary drilling, unless a gravel-pack is planned, in which case the depth of outer drillhole shall be a minimum of 35' plus the desired screen length in either type of drilling.	6" See construction conditions.	See construction conditions	6"	Not applicable	In a gravel-pack well construction, the gravel used shall be properly graded, washed sterilized igneous rock gravel free from foreign material. If filler pipes will be installed they shall not be attached to the protective well casing at an elevation less than 12' above the established ground grade at the well or the floor of a building or pump house or well house. The gravel-pack shall be placed through an adequately sized temporary pipe and the gravel-pack shall not extend to an elevation higher than 32' below the established ground surface. A minimum of a 2' sand seal shall be placed upon the gravel pack and the remainder of the annular space shall preferably be filled with cement grout placed by an approved pressure method, but drill cuttings or clay slurry will be acceptable. See note 1 below.

NOTE 1. Some drillers construct an enlarged upper drillhole to a depth of several feet with cable tool equipment by choice under geologic conditions of column 3, line b, to facilitate use of long lengths of pipe.

TABLE 3
HIGH CAPACITY, SCHOOL AND SEWAGE TREATMENT PLANT
DRILLED WELL REQUIREMENTS - POTABLE WATER SUPPLY

1 Type	2 Nature of Water Bearing Formation (Aquifer)	3 Geologic Formations Overlying Aquifer	4 Minimum Nominal Casing Diameter Inches	Upper Drillhole				9 Lower Drillhole Minimum Well Diameter	10 Maximum Nominal Protective Liner Diameter	11 Construction Conditions	
				Upper Enlarged Drillhole		Regular Drillhole					
				5 Minimum Diameter	6 Minimum Depth	7 Minimum Diameter	8 Bottom Elevation				
d.	Limestone (See note 2) or shale (See note 3)	Unconsolidated materials, mainly sand or gravel to depth of at least 60' to a radius of 1/2 mile. No record of sink holes, test holes, quarries or abandoned wells in above area.	6"	Casing outside diameter plus 3" if well casing pipe will be assembled with welded joints. Coupling outside diameter plus 3" if well casing will be assembled with threaded and coupled joints.	60' with cable tool drilling & to rock with rotary drilling, except for sewage treatment plant wells if rock lies at depth less than 100' the minimum depth of drillhole is 100'. See note 4 below.	6" with cable tool drilling. Not applicable with rotary drilling.	See construction conditions exception-see note 4 below.	6"	Pipe O.D. 3" less than lower drillhole diameter except that for wells 10" in dia. or less pipe dia. shall be nominal 2" less than drill-hole dia.	The protective well casing pipe shall be firmly seated in the rock formation. With cable tool drilling, the upper enlarged drillhole shall be kept open with temporary well casing and the annular space shall be permanently sealed with cement grout. With rotary drilling, the upper enlarged drillhole shall be maintained at full diameter with drilling mud or with temporary well casing and the annular space shall be permanently sealed with cement grout. Temporary outer casing shall be removed immediately following grouting. The vertical zone of contamination must be sealed off. See notes 1 and 4 below.	d, e, f Protective well casing pipe shall be placed concentrically within the upper enlarged drillhole having a minimum diameter conforming to column 5, lines d, e and f, depending upon the manner of assembly of pipe. The pipe shall be sealed in place with cement grout applied by a suitable pump from the bottom of the casing upward. Protective liner pipe shall be assembled with welded joints, placed concentrically within the drillhole and sealed in place with cement grout placed by a suitable pump or other approved method from the bottom of the liner pipe upward. When developing wells in the sandstone aquifer overlain by the "Maquoketa" shale and Niagara formation, the Niagara formation should be cased off in all cases and shall be cased off where the deep aquifer water has a high dissolved solids content. Liner pipe placed through the shale only to prevent casing shall be a minimum of 2" less in diameter than the drillhole and the bottom 20' shall be sealed in place with cement grout or clay slurry.
e.	Limestone (See note 2) or shale (See note 3)	Clay or similar material or such materials with some sand and gravel zones to depth of at least 60' to a radius of 1/2 mile. No record of sink holes, test holes, quarries or abandoned wells in above area.	6"	Casing outside diameter plus 3" if well casing pipe will be assembled with welded joints. Coupling outside diameter plus 3" if well casing will be assembled with threaded and coupled joints.	60' with cable tool drilling & to rock with rotary drilling, except for sewage treatment plant wells if rock lies at depth less than 100' the minimum depth of drillhole is 100'. See note 4 below.	6" with cable tool drilling. Not applicable with rotary drilling.	See construction conditions exception-see note 4 below.	6"	Pipe O.D. 3" less than lower drillhole diameter except that for wells 10" in dia. or less pipe dia. shall be nominal 2" less than drill-hole dia.	The protective well casing pipe shall be firmly seated into the rock formation. With cable tool drilling, the upper enlarged drillhole shall be kept 1/3 filled with clay slurry throughout the driving of the protective well casing, unless caving formations are expected, in which case a temporary outer casing shall be used. The annular space shall be permanently filled with cement grout applied in an approved manner. Construction conditions for drilling with rotary equipment are the same as above for d. Temporary outer casing shall be removed immediately following grouting. The vertical zone of contamination must be sealed off. See notes 1 and 4 below.	
f.	Limestone (See note 2) or shale (See note 3)	Unconsolidated materials for depth less than 60' within a radius of 1/2 mile. No record of sink holes, test holes, quarries or abandoned wells in above area.	6"	Casing outside diameter plus 3" if well casing pipe will be assembled with welded joints. Coupling outside diameter plus 3" if well casing will be assembled with threaded and coupled joints.	10' into uncreviced rock below 50' in either limerock or shale, except for sewage treatment plant wells the minimum depth is 100'. See note 4 below.	Not applicable.		6"	Pipe O.D. 3" less than lower drillhole diameter except that for wells 10" in dia. or less pipe dia. shall be nominal 2" less than drill-hole dia.	The upper enlarged drillhole through caving formations above the rock shall be kept open by temporary well casing with cable tool drilling and with such casing or drilling mud with rotary drilling. If the formation over the rock is clay or material which will similarly stand open, with rotary drilling the drill cuttings shall be removed by drilling mud. The annular space shall be permanently filled with cement grout. Temporary outer casing shall be removed immediately following grouting. The vertical zone of contamination must be sealed off. See notes 1 & 4 below.	

NOTE 1. Casing only to rock under conditions of column 3, lines d & e and to the depth indicated in column 6, line f for condition of column 3, line f, is only acceptable as a minimum when it is adequate to seal off the vertical zone of contamination. Greater depth of protective casing is required in areas where well histories show that the vertical zone of contamination extends to a greater depth.

NOTE 2. Although the carbonate rocks in this state are primarily dolomites, the term limestone has been given to them in the well construction specifications because it is the common term given to them by drillers.

NOTE 3. Wells normally shall not be developed into a shale formation. Such constructions are limited primarily to "Maquoketa" shale where the limestone is missing or very thin but only when the shale is known to be firm enough so that the drillhole will remain open and the water therefrom is not turbid. These wells may occur along the western edge of the Niagara dolomite extending from Door County to the Illinois border, at Blue Mound, at the Platteville Mound and in the Sinsinawa area in Grant County. Shale wells under similar geologic conditions in other areas of the state where overlying rock is missing or thin will also be acceptable.

NOTE 4. Minimum casing depths for sewage treatment plant wells shall be 100'.

TABLE 3
HIGH CAPACITY AND SCHOOL
DRILLED WELL REQUIREMENTS - NONPOTABLE WATER SUPPLY

1 Type	2 Nature of Water Bearing Formation (Aquifer)	3 Geologic Formations Overlying Aquifer	4 Minimum Nominal Casing Diameter Inches	Upper Drillhole				9 Lower Drillhole Minimum Well Diameter	10 Maximum Nominal Protective Liner Diameter	11 Construction Conditions	
				Upper Enlarged Drillhole		Regular Drillhole					
				5 Minimum Diameter	6 Minimum Depth	7 Minimum Diameter	8 Bottom Elevation				
g.	Limestone (See note 2) or shale (See note 3)	Unconsolidated materials, mainly sand or gravel, to depth of at least 40'.	6"	Casing diameter plus 4" if one is constructed with cable tool drilling. See construction conditions. Casing diameter plus 2" with rotary drilling.	None required with cable tool drilling. To rock with rotary drilling.	6" with cable tool drilling. Not applicable with rotary drilling.	See construction conditions	6"	Not applicable.	The protective well casing pipe shall be firmly seated in the rock formation. When an upper enlarged drillhole is constructed with cable tool equipment, the annular space shall be filled with clay slurry or cement grout placed in an approved manner. See note 1 below. With rotary drilling, the upper enlarged drillhole shall be maintained at full diameter with drilling mud or with temporary well casing and the annular space shall be permanently sealed with drilling mud or cement grout, except that only cement grout shall be used when the upper enlarged drillhole is constructed more than 2' into the limestone.	g, h Well casing pipe placed in an upper enlarged drillhole only 2" greater in diameter than the nominal well casing pipe diameter, as is only permissible with rotary drilling, shall be assembled with welded joints and sealed in place with drilling mud or cement grout placed in the annular space by a suitable pump from the bottom of the casing upward.
h.	Limestone (See note 2) or shale (See note 3)	Clay or similar material or such materials with some sand and gravel zones to depth of at least 40'.	6"	Casing diameter plus 4" with cable tool drilling. Casing diameter plus 2" with rotary drilling. See construction conditions.	To the bottom of the clay or to the 20' depth, whichever is the lesser, with cable tool drilling. To rock with rotary drilling.	6" with cable tool drilling. Not applicable with rotary drilling.	See construction conditions	6"	Not applicable.	The well casing shall be firmly seated into the rock formation. With cable tool drilling, the upper enlarged drillhole shall be kept 1/3 filled with clay slurry throughout the driving of the well casing, unless caving formations are expected, in which case a temporary outer casing shall be used. The annular space shall be permanently sealed with clay slurry or cement grout applied in an approved manner. Construction conditions are the same as for line g. Temporary outer casing shall be removed immediately following grouting of the well.	i The upper enlarged drillhole diameter need be only 2" greater than the nominal well casing pipe diameter when the well casing pipe is assembled with welded joints and the cement grout is placed in the annular space by a suitable pump or other approved pressure method from the bottom of the casing upward.
i.	Limestone (See note 2) or shale (See note 3)	Unconsolidated materials for depth less than 40'.	6"	Casing diameter plus 4" with cable tool drilling. Casing diameter plus 2" with rotary drilling. See construction conditions.	10' into uncreviced rock below 30' in limerock. 40' in shale.	Not applicable.		6"	Not applicable.	The upper enlarged drillhole through caving formations above the rock shall be kept open by temporary well casing with cable tool drilling and with such casing or drilling mud with rotary drilling. If the formation over the rock is clay or material which will similarly stand open, with rotary drilling the drill cuttings preferably shall be removed by drilling mud but use of air will be permitted for such geologic formations. The annular space shall be permanently filled with cement grout.	

NOTE 1. Some drillers construct an enlarged upper drillhole with cable tool equipment by choice under geologic conditions of column 3, line g, to facilitate use of longer lengths of pipe.
NOTE 2. Although the carbonate rocks in this state are primarily dolomites, the term limestone has been given to them in the well construction specifications because it is the common term given to them by drillers.
NOTE 3. Wells normally shall not be developed into a shale formation. Such constructions are limited primarily to "Maquoketa" shale where the limestone is missing or very thin but only when the shale is known to be firm enough so that the drillhole will remain open and the water therefrom is not turbid. These wells may occur along the western edge of the Niagara dolomite extending from Door County to the Illinois border, at Blue Mound, at the Platteville Mound and in the Sinsinawa area in Grant County. Shale wells under similar geologic conditions in other areas of the state where overlying rock is missing or thin will also be acceptable.

TABLE 3

HIGH CAPACITY, SCHOOL AND SEWAGE TREATMENT PLANT
DRILLED WELL REQUIREMENTS – POTABLE WATER SUPPLY

1 Type	2 Nature of Water Bearing Formation (Aquifer)	3 Geologic Formations Overlying Aquifer	4 Minimum Nominal Casing Diameter Inches	Upper Drillhole				9 Lower Drillhole Minimum Well Diameter	10 Maximum Nominal Protective Liner Diameter	11 Construction Conditions
				Upper Enlarged Drillhole		Regular Drillhole				
				5 Minimum Diameter	6 Minimum Depth	7 Minimum Diameter	8 Bottom Elevation			
j.	Granite or Quartzite (See note 1)	Unconsolidated materials mainly sand or gravel, to depth of at least 60' to a radius of 1/2 mile.	6"	Casing outside diameter plus 3" if well casing pipe will be assembled with welded joints. Coupling outside diameter plus 3" if well casing will be assembled with threaded and coupled joints.	60' with cable tool drilling & to rock with rotary drilling, except for sewage treatment plant wells if rock lies at depth less than 100' the minimum depth of drill-hole is 100'. See note 3 below.	6" with cable tool drilling. Not applicable with rotary drilling.	See construction conditions. Exception see note 3 below.	6"	Pipe O.D. 3" less than lower drillhole dia. except that for wells 10" in dia. or less pipe dia. shall be nominal 2" less than drill-hole dia.	The protective well casing pipe shall be firmly seated in the rock formation. With cable tool drilling, the upper enlarged drillhole shall be kept open with temporary well casing and the annular space shall be permanently sealed with cement grout. With rotary drilling, the upper enlarged drillhole shall be maintained at full diameter with drilling mud or with temporary well casing and the annular space shall be permanently sealed with cement grout. Temporary outer casing shall be removed immediately following grouting. The vertical zone of contamination must be sealed off. See notes 2 and 3 below.
k.	Granite or Quartzite (See note 1)	Clay or similar material or such materials with some sand and gravel zones to a depth of at least 60' to a radius of 1/2 mile.	6"	Casing outside diameter plus 3" if well casing pipe will be assembled with welded joints. Coupling outside diameter plus 3" if well casing will be assembled with threaded and coupled joints.	60' with cable tool drilling & to rock with rotary drilling, except for sewage treatment plant wells if rock lies at depth less than 100' the minimum depth of drill-hole is 100'. See note 3 below.	6" with cable tool drilling. Not applicable with rotary drilling.	See construction conditions. Exception see note 3 below.	6"	Pipe O.D. 3" less than lower drillhole dia. except that for wells 10" in dia. or less pipe dia. shall be nominal 2" less than drill-hole dia.	The protective well casing pipe shall be firmly seated into the rock formation. With cable tool drilling, the upper enlarged drillhole shall be kept 1/3 filled with clay slurry throughout the driving of the protective well casing, unless caving formations are expected, in which case a temporary outer casing shall be used. The annular space shall be permanently filled with cement grout applied in an approved manner. Construction conditions for drilling with rotary equipment are the same as above for j. Temporary outer casing shall be removed immediately following grouting. The vertical zone of contamination must be sealed off. See notes 2 and 3 below.
l.	Granite or Quartzite (See note 1)	Unconsolidated materials for depth less than 60' within a radius of 1/2 mile.	6"	Casing outside diameter plus 3" if well casing pipe will be assembled with welded joints. Coupling outside diameter plus 3" if well casing will be assembled with threaded and coupled joints.	60' except for sewage treatment plant wells the minimum depth is 100'. See note 3 below.	Not applicable.		6"	Pipe O.D. 3" less than lower drillhole dia. except that for wells 10" in dia. or less pipe dia. shall be nominal 2" less than drill-hole dia.	The upper enlarged drillhole through caving formations above the rock shall be kept open by temporary well casing with cable tool drilling and with such casing or drilling mud with rotary drilling. If the formation over the rock is clay or material which will similarly stand open, with rotary drilling the drill cuttings shall be removed by drilling mud. The annular space shall be permanently filled with cement grout. Temporary outer casing shall be removed immediately following grouting. The vertical zone of contamination must be sealed off. See notes 2 and 3 below.

NOTE 1. Crystalline rocks are classed as granite because they are commonly referred to as granite by drillers regardless of their true rock type. This includes trap rock.

NOTE 2. Casing only to rock under conditions of column 3, lines j & k and to the depth indicated in column 6, line 1, for condition of column 3, line 1, is only acceptable as a minimum when it is adequate to seal off the vertical zone of contamination. Greater depth of protective casing is required in areas where well histories show that the vertical zone of contamination extends to a greater depth.

NOTE 3. Minimum casing depths for sewage treatment plant wells shall be 100'.

TABLE 3
HIGH CAPACITY AND SCHOOL
DRILLED WELL REQUIREMENTS - NONPOTABLE WATER SUPPLY

1 Type	2 Nature of Water Bearing Formation (Aquifer)	3 Geologic Formations Overlying Aquifer	4 Minimum Nominal Casing Diameter Inches	Upper Drillhole				9 Lower Drillhole Minimum Well Diameter	10 Maximum Nominal Protective Liner Diameter	11 Construction Conditions
				Upper Enlarged Drillhole		Regular Drillhole				
				5 Minimum Diameter	6 Minimum Depth	7 Minimum Diameter	8 Bottom Elevation			
m.	Granite or Quartzite (See note 1)	Unconsolidated materials mainly sand or gravel, to depth of at least 40'.	6"	Casing diameter plus 4" if one is constructed with cable tool drilling. See construction conditions. Casing diameter plus 2" with rotary drilling.	None required with cable tool. To rock with rotary drilling.	6" with cable tool drilling. Not applicable with rotary drilling.	See construction conditions.	6"	Not applicable	The well casing pipe shall be firmly seated in the rock formation. When an enlarged upper drillhole is constructed with cable tool equipment, the annular space shall be filled with clay slurry or cement grout placed in an approved manner. See note 2 below. With rotary drilling equipment, the upper enlarged drillhole shall be maintained at full diameter with drilling mud or temporary well casing and the annular space shall be permanently sealed with drilling mud or cement grout, except that only cement grout shall be used when the upper enlarged drillhole is constructed more than 2' into the granite.
n.	Granite or Quartzite (See note 1)	Clay or similar material or such materials with some sand and gravel zones to a depth of at least 40'.	6"	Casing diameter plus 4" with cable tool drilling. Casing diameter plus 2" with rotary drilling. See construction conditions.	To the bottom of the clay or to the 20' depth whichever is the lesser with cable tool drilling. To rock with rotary drilling.	6" with cable tool drilling. Not applicable with rotary drilling.	See construction conditions.	6"	Not applicable	The well casing shall be firmly seated into the rock formation. With cable tool drilling, the upper enlarged drillhole shall be kept 1/3 filled with clay slurry throughout the driving of the well casing, unless caving formations are expected, in which case a temporary outer casing shall be used. The annular space shall be permanently sealed with clay slurry or cement grout applied in an approved manner. Construction conditions are the same as for line m. Temporary outer casing shall be removed immediately following grouting of the well.
o.	Granite or Quartzite (See note 1)	Unconsolidated materials for depth less than 40'.	6"	Casing diameter plus 4" with cable tool drilling. Casing diameter plus 2" with rotary drilling. See construction conditions.	40'	Not applicable		6"	Not applicable	The upper enlarged drillhole through caving formations above the rock shall be kept open by temporary well casing with cable tool drilling and with such casing or drilling mud with rotary drilling. If the formation over the rock is clay or material which will similarly stand open, with rotary drilling the drill cuttings preferably shall be removed by drilling mud but use of air will be permitted for such geologic formations. The annular space shall be permanently filled with cement grout.

NOTE 1. Crystalline rocks are classed as granite because they are commonly referred to as granite by drillers regardless of their true rock type. This includes trap rock.
NOTE 2. Some drillers construct an enlarged upper drillhole with cable tool equipment by choice under geologic conditions of column 3, line m, to facilitate use of longer lengths of pipe.

TABLE 3
HIGH CAPACITY, SCHOOL AND SEWAGE TREATMENT PLANT
DRILLED WELL REQUIREMENTS – POTABLE WATER SUPPLY

1 Type	2 Nature of Water Bearing Formation (Aquifer)	3 Geologic Formations Overlying Aquifer	4 Minimum Nominal Casing Diameter Inches	Upper Drillhole				9 Lower Drillhole Minimum Well Diameter	10 Maximum Nominal Protective Liner Diameter	11 Construction Conditions	
				Upper Enlarged Drillhole		Regular Drillhole					
				5 Minimum Diameter	6 Minimum Depth	7 Minimum Diameter	8 Bottom Elevation				
p.	Sandstone	Unconsolidated materials mainly sand and gravel to a depth of 60' or more.	6"	Casing outside diameter plus 3" if well casing pipe will be assembled with welded joints. Coupling outside diameter plus 3" if well casing will be assembled with threaded and coupled joints.	60' with cable tool drilling & to rock with rotary drilling, except for sewage treatment plant wells if rock lies at depth less than 100' the minimum depth of drillhole is 100'. See note 2 below.	6" with cable tool drilling. Not applicable with rotary drilling.	See construction conditions. Exception see note 2 below.	6"	Pipe O.D. 3" less than lower drillhole dia. except that for wells 10" in dia. or less pipe dia. shall be nominal 2" less than drillhole dia.	The protective well casing pipe shall be firmly seated in the rock formation. With cable tool drilling, the upper enlarged drillhole shall be kept open with temporary well casing and the annular space shall be permanently sealed with cement grout. With rotary drilling, the upper enlarged drillhole shall be maintained at full diameter with drilling mud or with temporary well casing and the annular space shall be permanently sealed with cement grout. Temporary outer casing shall be removed immediately following grouting. The vertical zone of contamination must be sealed off. See notes 1 and 2 below.	p, q, r Protective well casing pipe shall be placed concentric within the upper enlarged drillhole having a minimum diameter conforming to column 5, lines p, q and r, depending upon the manner of assembly of pipe. The pipe shall be sealed in place with cement grout applied by a suitable pump from the bottom of the casing upward.
q.	Sandstone	Clay or similar material or such material with some sand and gravel zones to depth of 60' or more.	6"	Casing outside diameter plus 3" if well casing pipe will be assembled with welded joints. Coupling outside diameter plus 3" if well casing will be assembled with threaded and coupled joints.	60' with cable tool drilling & to rock with rotary drilling, except for sewage treatment plant wells if rock lies at depth less than 100' the minimum depth of drillhole is 100'. See note 2 below.	6" with cable tool drilling. Not applicable with rotary drilling.	See construction conditions. Exception see note 2 below.	6"	Pipe O.D. 3" less than lower drillhole dia. except that for wells 10" in dia. or less pipe dia. shall be nominal 2" less than drillhole dia.	The protective well casing pipe shall be firmly seated into the rock formation. With cable tool drilling, the upper enlarged drillhole shall be kept 1/3 filled with clay slurry throughout the driving of the protective well casing, unless caving formations are expected, in which case a temporary outer casing shall be used. The annular space shall be permanently filled with cement grout applied in an approved manner. Construction conditions for drilling with rotary equipment are the same as above for p. Temporary outer casing shall be removed immediately following grouting. The vertical zone of contamination must be sealed off. See notes 1 and 2 below.	Protective liner pipe shall be assembled with welded joints placed concentric with the drillhole and sealed in place with cement grout placed by a suitable pump other approved method from the bottom of the liner pipe upward.
r.	Sandstone	Any material except limestone to a depth of less than 60'.	6"	Casing outside diameter plus 3" if well casing pipe will be assembled with welded joints. Coupling outside diameter plus 3" if well casing will be assembled with threaded and coupled joints.	Into firm sandstone or to the 60' depth whichever is greater, except for sewage treatment plant wells the minimum depth is 100'. See note 2 below.	Not applicable.		6"	Pipe O.D. 3" less than lower drillhole dia. except that for wells 10" in dia. or less pipe dia. shall be nominal 2" less than drillhole dia.	The upper enlarged drillhole through caving formations above the rock shall be kept open by temporary well casing with cable tool drilling and with such casing or drilling mud with rotary drilling. If the formation over the rock is clay or material which will similarly stand open, with rotary drilling the drill cuttings shall be removed by drilling mud. The annular space shall be permanently filled with cement grout. Temporary outer casing shall be removed immediately following grouting. The vertical zone of contamination must be sealed off. See notes 1 and 2 below.	

NOTE 1. Casing only to rock under conditions of column 3, lines p and q and to the depth indicated in column 6, line r for condition of column 3, line r, is only acceptable as a minimum when it is adequate to seal off the vertical zone of contamination. Greater depth of protective casing is required in areas where well histories show that the vertical zone of contamination extends to a greater depth.

NOTE 2. Minimum casing depth for sewage treatment plant wells shall be 100'.

TABLE 3
HIGH CAPACITY AND SCHOOL
DRILLED WELL REQUIREMENTS - NONPOTABLE WATER SUPPLY

1 Type	2 Nature of Water Bearing Formation (Aquifer)	3 Geologic Formations Overlying Aquifer	4 Minimum Nominal Casing Diameter Inches	Upper Drillhole				9 Lower Drillhole Minimum Well Diameter	10 Maximum Nominal Protective Liner Diameter	11 Construction Conditions	
				Upper Enlarged Drillhole		Regular Drillhole					
				5 Minimum Diameter	6 Minimum Depth	7 Minimum Diameter	8 Bottom Elevation				
s.	Sandstone	Unconsolidated materials mainly sand and gravel to a depth of 25' or more.	6"	Casing diameter plus 4" if one is constructed with cable tool drilling. See construction conditions. Casing diameter plus 2" with rotary drilling.	None required with cable tool. Into firm sandstone with rotary drilling.	6" with cable tool drilling. Not applicable with rotary drilling.	See construction conditions.	6"	Not applicable.	The well casing pipe shall be firmly seated in the rock formation. When an upper enlarged drillhole is constructed with cable tool equipment, the annular space shall be filled with clay slurry or cement grout placed in an approved manner. See note 1 below. With rotary drilling, the upper enlarged drillhole shall be maintained at full diameter with drilling mud or with temporary well casing and the annular space shall be permanently sealed with drilling mud or cement grout, except that only cement grout shall be used when the upper enlarged drillhole is constructed more than 2' into the sandstone.	s, t Well casing pipe placed in an upper enlarged drillhole only 2" greater in diameter than the nominal well casing pipe diameter, as is only permissible with rotary drilling, shall be assembled with welded joints and sealed in place with drilling mud or cement grout placed in the annular space by a suitable pump from the bottom of the casing upward.
t.	Sandstone	Clay or similar material or such material with some sand and gravel zones to depth of 25' or more.	6"	Casing diameter plus 4" with cable tool drilling. Casing diameter plus 2" with rotary drilling. See construction conditions.	To the bottom the clay or to the 20' depth whichever is the lesser, with cable tool drilling. Into firm sandstone with rotary drilling.	6" with cable tool drilling. Not applicable with rotary drilling.	See construction conditions.	6"	Not applicable.	The well casing pipe shall be firmly seated in the rock formation. With cable tool drilling, the upper enlarged drillhole shall be kept open by temporary well casing, when necessary and shall be kept 1/3 filled with clay slurry throughout the driving of the well casing. The balance of the annular space shall be filled with clay slurry or cement grout applied in an approved manner. Construction conditions for drilling with rotary equipment are the same as above for line s.	
u.	Sandstone	Any material except limestone to a depth of less than 25'.	6"	Casing diameter plus 4" with cable tool drilling. Casing diameter plus 2" with rotary drilling. See construction conditions.	Into firm sandstone or to the 30' depth whichever is greater.	Not applicable.		6"	Not applicable.	The upper enlarged drillhole through caving formations above the rock shall be kept open by temporary well casing with cable tool drilling and by such casing or drilling mud with rotary drilling. If the formation over the rock is clay or material which will similarly stand open, with rotary drilling the drill cuttings preferably shall be removed by mud but use of air will be permitted for such geologic formations. The annular space surrounding the well casing shall be permanently filled with cement grout.	

NOTE 1. Some drillers construct enlarged upper drillholes to a depth of several feet with cable tool equipment by choice under geologic conditions of column 3, line s, to facilitate use of longer lengths of pipe.

TABLE 3
HIGH CAPACITY, SCHOOL AND SEWAGE TREATMENT PLANT
DRILLED WELL REQUIREMENTS - POTABLE WATER SUPPLY

1 Type	2 Nature of Water Bearing Formation (Aquifer)	3 Geologic Formations Overlying Aquifer	4 Minimum Nominal Casing Diameter Inches	Upper Drillhole				9 Lower Drillhole Minimum Well Diameter	10 Maximum Nominal Protective Liner Diameter	11 Construction Conditions	
				Upper Enlarged Drillhole		Regular Drillhole					
				5 Minimum Diameter	6 Minimum Depth	7 Minimum Diameter	8 Bottom Elevation				
v.	Sandstone	Limestone to depth of 60' or less with or without unconsolidated overburden over the limestone.	6"	Casing outside diameter plus 3" if well casing pipe will be assembled with welded joints. Coupling outside diameter plus 3" if well casing will be assembled with threaded and coupled joints.	60' or 15' into firm sandstone, whichever is greater, except for sewage treatment plant wells the minimum is 100'. See note 3 below.	Not applicable.		6"	Pipe O.D. 3" less than lower drillhole dia. except that for wells 10" in dia. or less pipe dia. shall be nominal 2" less than drill-hole dia.	The upper enlarged drillhole through caving formations above the rock shall be kept open by temporary well casing with cable tool drilling and by such casing or drilling mud with rotary drilling. If the formation over the rock is clay or material which will similarly stand open, with rotary drilling the drill cuttings preferably shall be removed by mud but use of air will be permitted for such geologic formation. The annular space surrounding the protective well casing shall be permanently filled with cement grout. The vertical zone of contamination must be sealed off. See notes 2 & 3 below.	v, w Protective well casing pipe shall be placed concentrically within the upper enlarged drillhole having a minimum diameter conforming to column 5, lines v, and w, depending upon the manner of assembly of pipe. The pipe shall be sealed in place with cement grout applied by a suitable pump from the bottom of the casing upward.
w.	Sandstone	Limestone extending to a depth greater than 60' with or without unconsolidated overburden over the limestone.	6"	Casing outside diameter plus 3" if well casing pipe will be assembled with welded joints. Coupling outside diameter plus 3" if well casing will be assembled with threaded and coupled joints.	10' into uncreviced rock below 50', except for sewage treatment plant wells the minimum depth is 100'. See note 3 below.	Not applicable.		6"	Pipe O.D. 3" less than lower drillhole dia. except that for wells 10" in dia. or less pipe dia. shall be nominal 2" less than drill-hole dia.	Protective liner pipe shall be assembled with welded joints, placed concentrically within the drillhole and sealed in place with cement grout placed by a suitable pump or other approved method from the bottom of the liner pipe upward.	

NOTE 1. Although the carbonate rocks in this state are primarily dolomites, the term limestone has been given to them in the well construction specifications because it is the common term given to them by the drillers.
NOTE 2. Casing only to the depth indicated in column 6, lines v & w, for conditions of column 3, lines v & w, is only acceptable as a minimum when it is adequate to seal off the vertical zone of contamination. Greater depth of protective casing is required in areas where well histories show that the vertical zone of contamination extends to a greater depth.
NOTE 3. Minimum casing depth for sewage treatment plant wells shall be 100'.

TABLE 3
HIGH CAPACITY AND SCHOOL
DRILLED WELL REQUIREMENTS - NONPOTABLE WATER SUPPLY

1 Type	2 Nature of Water Bearing Formation (Aquifer)	3 Geologic Formations Overlying Aquifer	4 Minimum Nominal Casing Diameter Inches	Upper Drillhole				9 Lower Drillhole Minimum Well Diameter	10 Maximum Nominal Protective Liner Diameter	11 Construction Conditions
				Upper Enlarged Drillhole		Regular Drillhole				
				5 Minimum Diameter	6 Minimum Depth	7 Minimum Diameter	8 Bottom Elevation			
x.	Sandstone	Limestone to depth of 40' or less with or without unconsolidated overburden over the limestone.	6"	Casing diameter plus 4" with cable tool drilling. Casing diameter plus 2" with rotary drilling. See construction conditions.	40'	Not applicable.		6"	Not applicable.	<p>The upper enlarged drillhole through caving formations above the rock shall be kept open by temporary well casing with cable tool drilling and by such casing or drilling mud with rotary drilling. If the formation over the rock is clay or material which will similarly stand open, with rotary drilling the drill cuttings preferably shall be removed by mud but use of air will be permitted for such geologic formation. The annular space surrounding the well casing shall be permanently filled with cement grout.</p> <p>The upper enlarged drillhole diameter need be only 2" greater than the nominal well casing pipe diameter when the well casing pipe is assembled with welded joints and the cement grout is placed in the annular space by a suitable pump or other approved pressure method from the bottom of the casing upward.</p>
y.	Sandstone	Limestone extending to a depth greater than 40' with or without unconsolidated overburden over the limestone.	6"	Casing diameter plus 4" with cable tool drilling. Casing diameter plus 2" with rotary drilling. See construction conditions.	40'	Not applicable.		6"	Not applicable.	<p>x, y Well casing pipe placed in an upper enlarged drillhole only 2" greater in diameter than the nominal well casing pipe diameter, shall be assembled with welded joints and sealed in place with cement grout placed in the annular space by a suitable pump from the bottom of the casing upward.</p>

NOTE 1. Although the carbonate rocks in this state are primarily dolomites, the term limestone has been given to them in the well construction specifications because it is the common term given to them by the drillers.

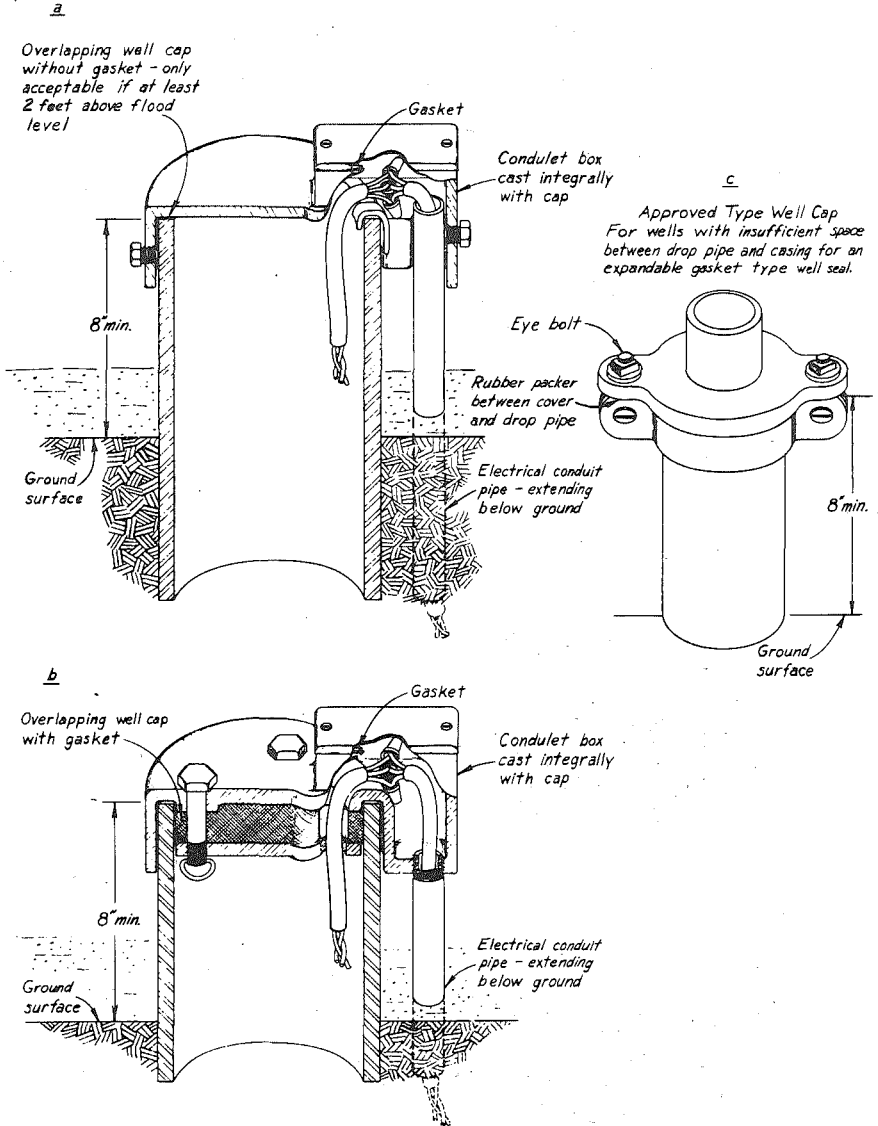

Figure 10. Types of Well Seals. (a) overlapping well cap with skirted sides. (b) and (c) seals using compressible rubber gaskets. See NR 112.17(2) and (4).

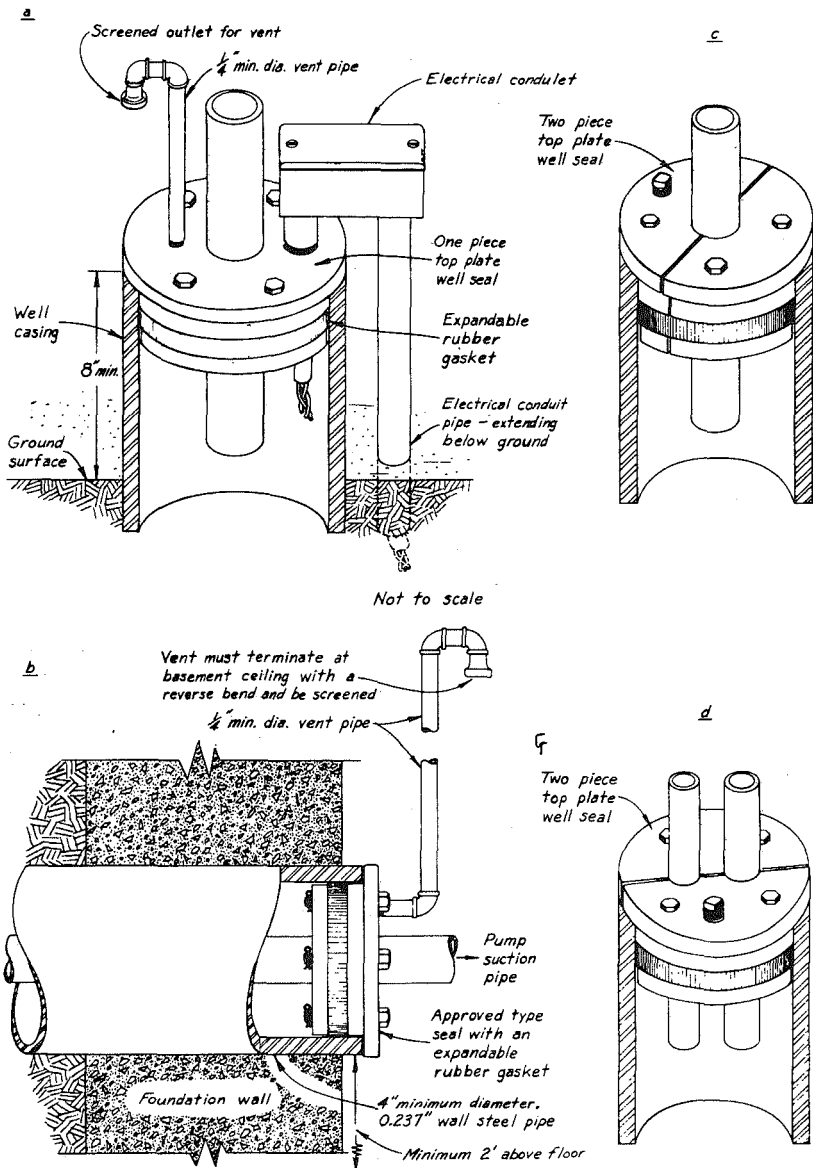

Figure 11. Types of Well Seals. (a) top of well seal using compressible rubber gasket. (c) and (d) also top of well seals with compressible rubber gaskets but with split top and bottom plates and gasket requiring acceptable housing protection. (b) nonpressure conduit seal using compressible rubber gasket. See NR 112.17(2) and (4).

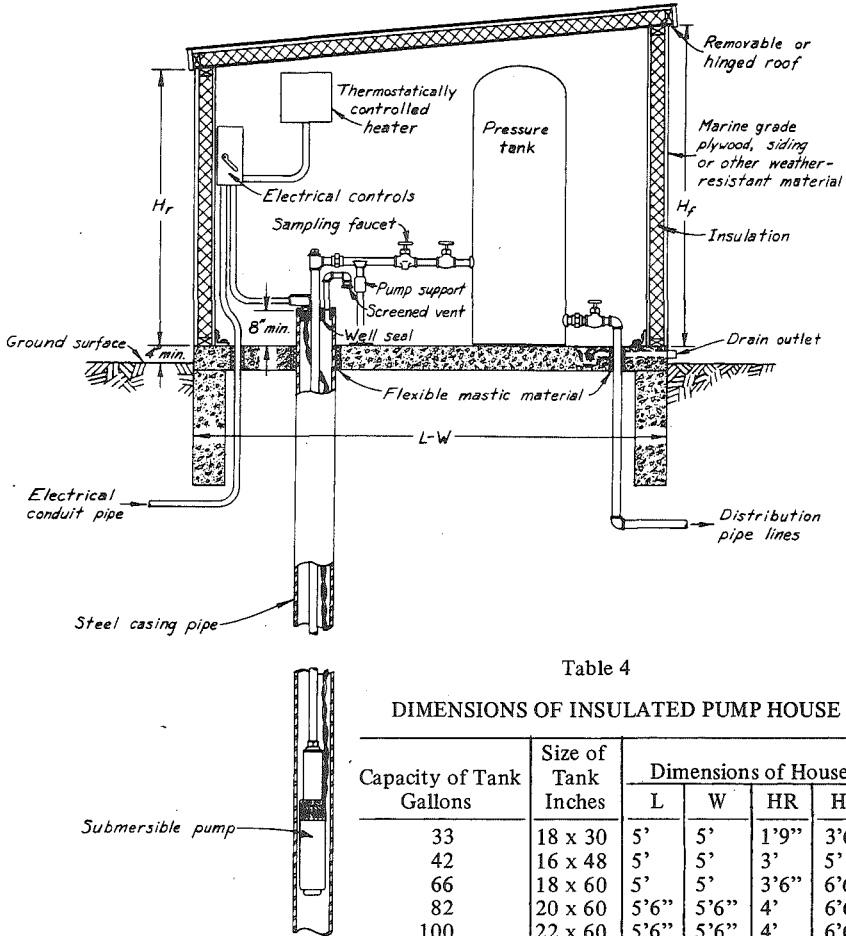

Table 4

DIMENSIONS OF INSULATED PUMP HOUSE

Capacity of Tank Gallons	Size of Tank Inches	Dimensions of House			
		L	W	HR	HF
33	18 x 30	5'	5'	1'9"	3'6"
42	16 x 48	5'	5'	3'	5'
66	18 x 60	5'	5'	3'6"	6'6"
82	20 x 60	5'6"	5'6"	4'	6'6"
100	22 x 60	5'6"	5'6"	4'	6'6"
120	24 x 60	5'6"	5'6"	4'	6'6"
220	30 x 72	6'6"	6'6"	5'	7'6"

Figure 12. Insulated Pumphouse Enclosing Pressure Tank.

WISCONSIN ADMINISTRATIVE CODE

292

NR 112

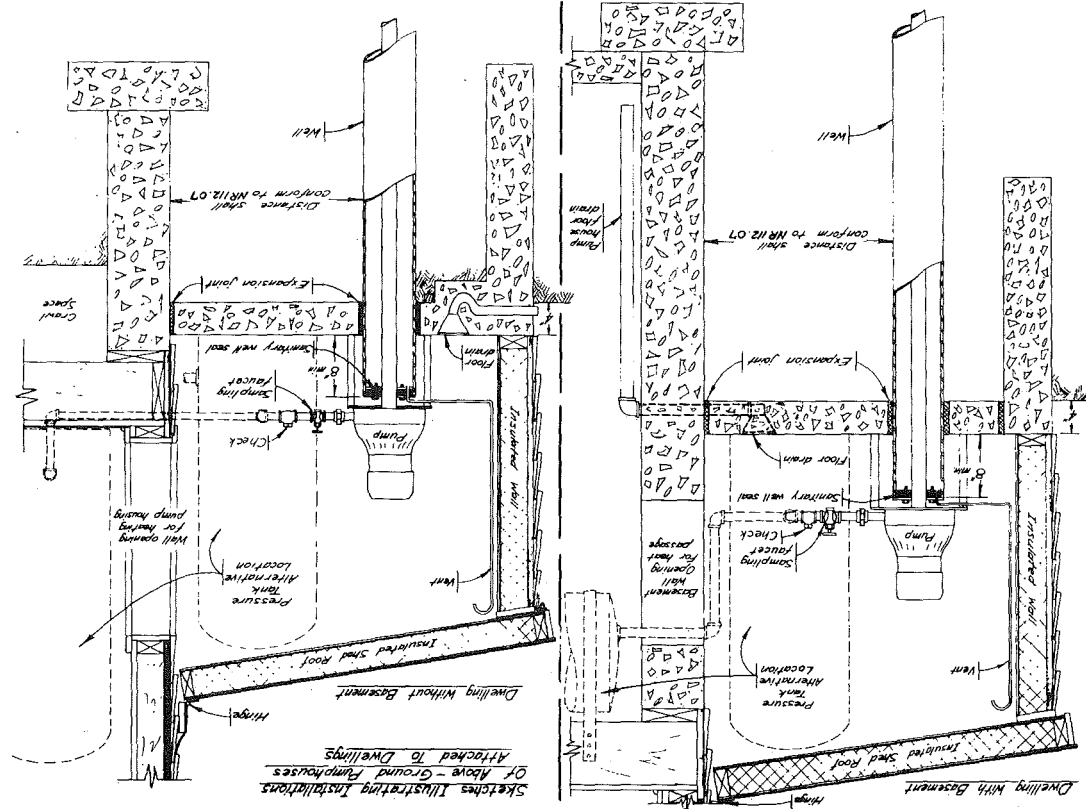

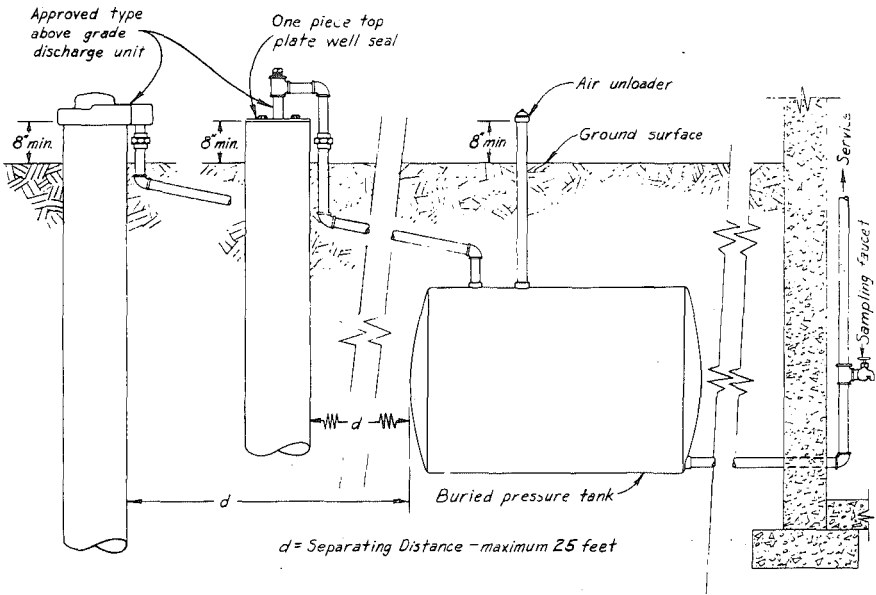

Figure 14. Pump Installations using Submersible Pumps and Approved Above-Ground Discharge Unit.

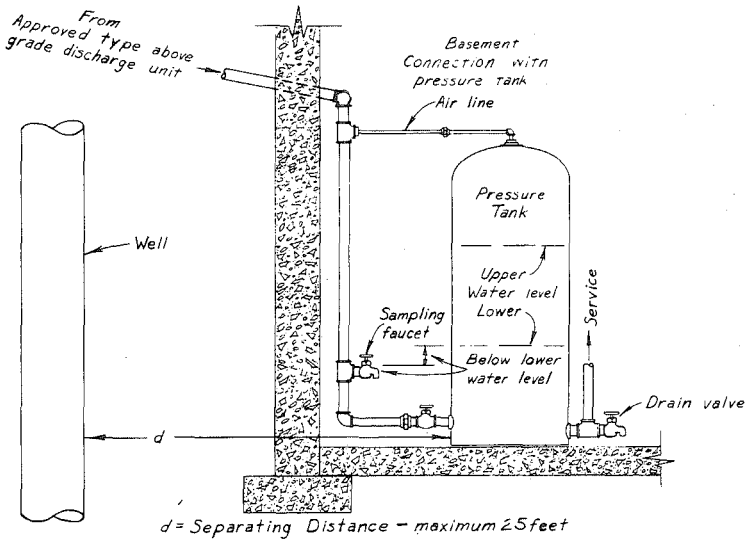

Figure 15. Alternative Pressure Tank Location with Submersible Pump Installation and Approved Above-Ground Discharge Unit.

(5) **RESERVOIR CONSTRUCTION.** (a) A subsurface ground storage reservoir may be used to store water for drinking and other domestic purposes providing that it is constructed in accordance with the following minimum specifications:

1. **Floor.** The floor of a reservoir shall be reinforced poured concrete with a thickness of at least 5 inches and a curbing wall 6 inches high and 6 inches thick, having a keyway for a construction joint with the walls. Any pump supply pipe and service pipe planned to extend through the floor, any copper water stop strip for the wall construction joint, and any reservoir drain facility shall be installed during the time of pouring the concrete floor.

2. **Walls.** The walls of a reservoir shall be reinforced poured concrete at least 6 inches thick. Should it be planned to install the pump supply pipe to the reservoir through a wall and to install the service line pipe in a wall as opposed to installation of the units in the reservoir floor, the pipe fittings for such units shall be installed at the time of pouring the walls so as to effect a watertight joint.

3. **Roof.** The roof shall be reinforced poured concrete at least 5 inches thick. An access manhole at least 24 inches in diameter or 24 inches square shall be constructed as an integral part of the reservoir roof. The manhole shall have a curbing wall extending at least 12 inches above the earth covering the roof or at least 6 inches higher than the roof, if the roof is not buried. The manhole curbing preferably shall be constructed entirely of 4-inch thick reinforced poured concrete, but may be partially steel or cast iron. The curbing shall be provided with a snug fitting, overlapping cover with a minimum of 3-inch wide skirted sides. The cover preferably shall be constructed with welded sheet steel but may be constructed with reinforced poured concrete.

4. **Overflow.** An overflow pipe, if used, shall be located just under the roof of the reservoir entirely above grade and terminate with a down-turned pipe at a point at least 12 inches above the ground grade. The pipe shall have a screened outlet. The overflow pipe shall be of sufficient diameter to permit waste of water at a rate in excess of the well pump operating capacity.

5. **Vent pipe.** A vent pipe shall be installed whenever the roof of the reservoir will terminate below the ground surface or at an inadequate distance above grade to permit installation of an overflow pipe in a reservoir wall just below the roof. The diameter of such vent pipe shall be large enough so that it can act as an overflow pipe to permit waste of water in excess of the well pump operating capacity. It shall be installed in the reservoir roof at the time of construction of the roof and shall be encased with 6 inches of concrete from the top of the roof to the ground surface if the roof is buried. The vent pipe shall terminate with a "U" bend with screened outlet a minimum of one foot above the ground grade or top of the reservoir. (Note: See Figures 16 and 17 for acceptable pump installation with reservoir.)

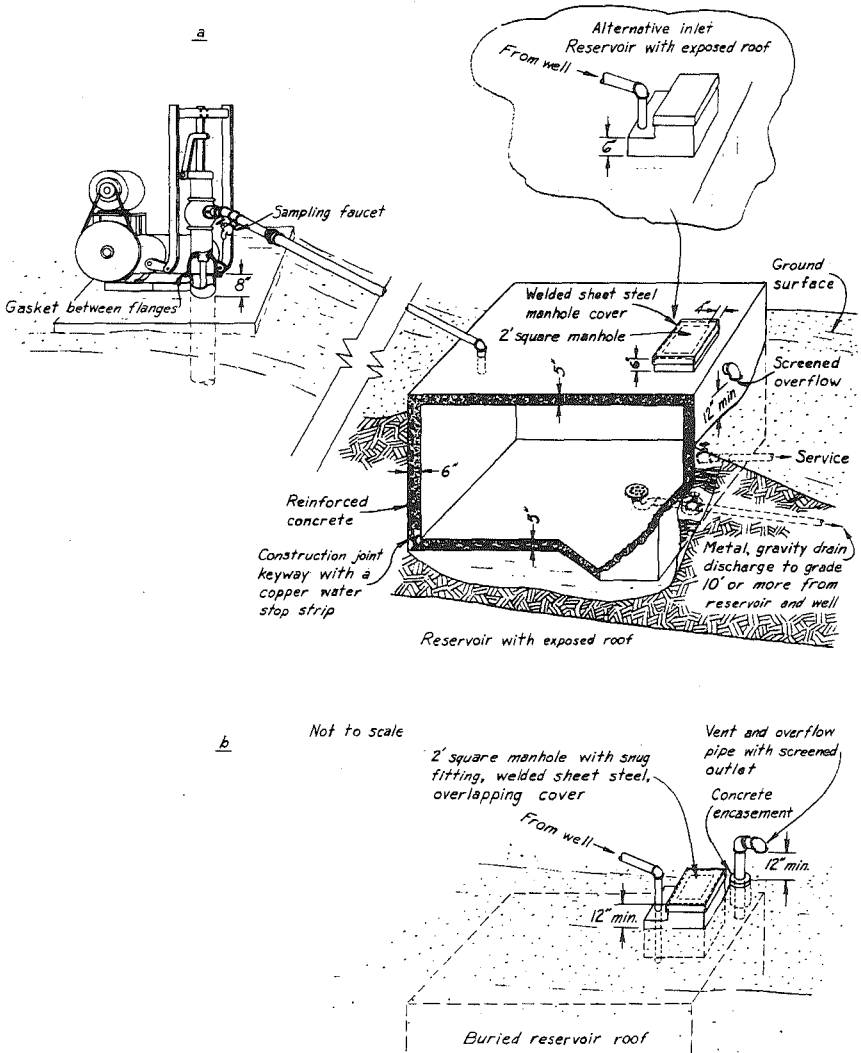

Figure 16. Water Storage Reservoir. (b) shows Acceptable Method of Supplying Water to Reservoir from pump when roof of reservoir is buried.

6. Supply pipe. Any gravity supply pipe from a hand type pump shall be assembled with permanent pipe fittings and shall be conducted into the reservoir through the roof or curbing for the manhole, if the roof is not buried, and only through the manhole curbing if the roof is buried. A supply pipe may be connected to the reservoir below grade provided that it will be under no less than 5 feet of head at any time. This will necessitate a pitless adapter installation, either with a submersible or deep well reciprocating type pump. The supply pipe in such case shall terminate at or no more than a few inches above the bottom of the reservoir and a float control switch or low and high water level electrical pump-control rods shall be installed. Any check valve shall be placed only in the portion of the pump discharge pipe located within the well. The supply and service pipe may be combined.

(6) PRESSURE VESSELS: (a) *Steel pressure vessels.* All steel tanks for containing water under pressure for domestic supplies, including those having an air space for expansion, shall meet the following specifications:

1. They shall have a $\frac{1}{4}$ inch minimum side wall and head wall thickness, when the tanks are approved pitless receiver units attached directly to well casings.

2. They shall have a $\frac{3}{16}$ -inch minimum side wall and head wall thickness when the tanks will be buried within 10 feet of wells.

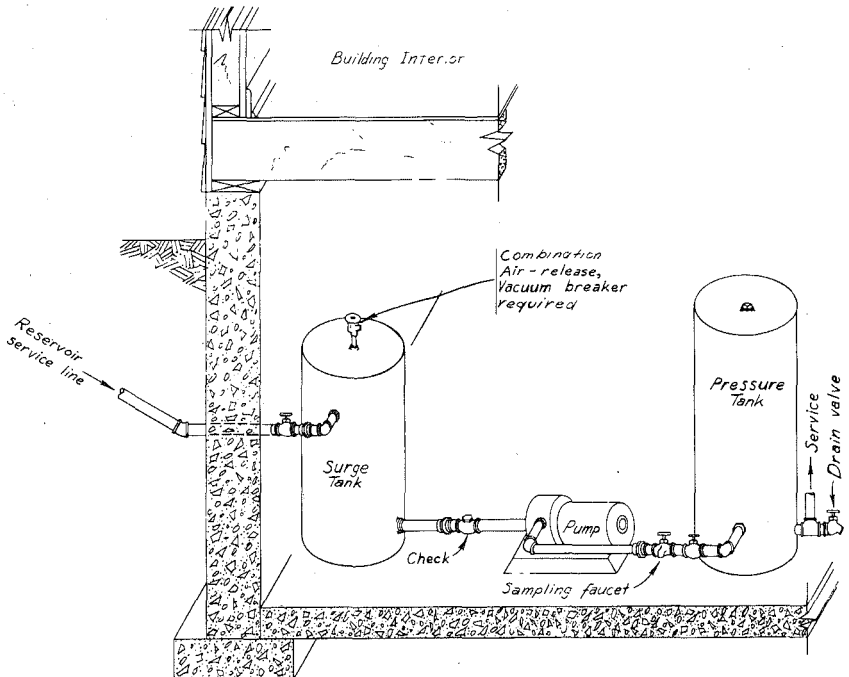

Figure 17. Acceptable Installation of Booster Pump on Service Line from Reservoir, when necessary.

3. They shall be identified by stamping showing the manufacturer's name, a serial number, the allowable working pressure and the year fabricated.

4. No tanks relying on expansion of a rubber cylinder or liner within a restricting metal container rather than on compression of air to provide pressure in the water supply system shall be used unless approved by the department. Approvals are based on strength of container and information indicating either National Sanitation Foundation (NSF) or Food and Drug Administration (FDA) approved products are used.

5. Inner tank surface paints and other coatings shall comply with the American Water Works Association (AWWA) standard D102 and be approved by the department. The AWWA Standard D102 is available for inspection at the offices of the department of natural resources, the secretary of state, and the revisor of statutes and may be obtained for personal use from the American Water Works Association, Inc., 6666 W. Quincey Ave., Denver, Colorado 80235.

6. No floating discs shall be used in tanks to reduce the air-water contact surface unless the disc material is approved by the department. Approvals are based on information indicating either NSF or FDA approved products are used.

(b) *Nonmetal pressure vessels.* No nonmetal tanks for containing water under pressure for domestic supplies, including those having an air space for expansion shall be used unless approved by the department. Approvals are based on strength of container and information indicating either NSF or FDA approved products are used and practicability in making pipe connections.

(Note: For safety requirements for both steel and nonmetal pressure vessels, consult Wis. Adm. Code, chapter Ind. 41, which contains the Boiler & Pressure Vessel Code of the department of industry, labor and human relations.)

(7) **PIPE MATERIALS.** Pump piping shall conform to the State Plumbing Code as set forth in Wis. Adm. Code, chapter H62. Limitations on use of plastic pipe are also found in chapter H62. Similar quality plastic pipe will be acceptable as drop pipe installed entirely within a well below the well seal.

(8) **WELL VENT.** Any well vent pipe shall be installed watertight to a point not less than 24 inches above any known flood water level but at least 6 inches above the top of the well except that in well pits or subsurface pumphrooms or when a vent exists in the well seal at the basement end of a nonpressure conduit the vent pipe shall extend to the ceiling of the structure. Such pipe shall be not less than $\frac{1}{4}$ inch in diameter and shall be firmly attached to a well seal or base of a deep well vertical centrifugal pump when one is installed. The vent pipe shall be terminated in a reverse bend and be screened so as to prevent entrance of foreign matter. Any opening in a pump base shall be sealed watertight.

(9) **SAMPLING FAUCET.** (a) In all pressure water systems provision shall be made for collection of water samples by installation of a sampling faucet on the discharge side of the pump. Such faucet shall be installed between the pump and a reservoir or between a pump and pressure tank when the tank is not buried, or when the tank position or the type of pump installation permits this without loss of air from the tank.

(b) In the case of buried pressure tanks, when either an approved type pitless adapter or an approved type above-ground discharge unit, depending on displacement of water in the exposed discharge pipe by air from the tank for frost protection, is installed, a sampling faucet is required in the service line from the tank at a point immediately following the point of entry into the building or building basement.

(c) When an approved above ground discharge unit is used, and the tank is in the basement the sampling faucet must be installed in the service pipe from the tank at an elevation sufficiently above the floor to facilitate obtaining a water sample unless the installation is so made that a sampling faucet can be placed in the discharge line without the problem of permitting loss of air from the system when the faucet is opened. Drain valves for tanks which are often placed in the service line from the tank at a point very near the floor are not acceptable as a sampling faucet.

(10) CASING NOT PART OF PUMP INSTALLATION. In areas where ground water is known to be corrosive, no pipe serving as the casing of any well shall be used as a delivery pipe or be utilized in the pumping operation. Moving pump parts located in any well shall be enclosed.

(11) DISINFECTION AND SAMPLING. Upon completing the installation of pumping equipment, the installer thereof shall disinfect the equipment by disinfecting the well and drawing water into the system by pumping and shall sample water in accordance with NR 112.15(3) (a) and (b) and NR 112.16(1) and (4).

(12) EMERGENCY PUMP INSTALLATIONS. No pump shall be repaired and reinstalled or newly installed for a well when it is a nonconforming structure except that a pump may be reinstalled or newly installed in such well in an emergency situation provided that the owner is informed in writing of the needed correction or replacement of the well, as the case may be, and a copy of such communication is filed with the department.

(13) PUMP INSTALLATIONS FOR FLOWING WELLS. (a) *Underground pipe connections.* No underground pipe connections shall be made to a flowing well except when an approved type pitless adapter is used.

(b) *Suction lines.* No shallow well type pump shall be connected directly to the pipe connected to a pitless adapter of a flowing well or to a pipe extending out of the seal at the top of the well and redirected back into the ground and over to a building basement. Such piping from the well shall enter a surge tank having either an overflow pipe or a vacuum breaker valve installed in the top of the tank. Any booster pump shall be connected to the surge tank and can discharge into a hydro-pneumatic tank.

(c) *Overflow piping.* 1. Where possible, once an artesian well is placed in use, the flow from the well to waste shall be stopped.

2. If the well has been constructed in conformance with section NR 112.08(3), a controlled overflow pipe may be installed, if necessary, to prevent physical damage due to escaping water upward outside the well casing or to prevent a freezing problem from occurring in the top portion of the well.

3. Any overflow to prevent freezing shall be limited to the absolute minimum to preserve ground water and pressure. The overflow pipe may be either installed at the top of the well or on a surge tank. The overflow pipe shall terminate at least 2 pipe diameters above a drain at the well site or in a building or building basement. (**Note:** Illustrations of acceptable pump installations with flowing wells are illustrated in figures 18 through 24.)

History: Cr. Register, June, 1975, No. 234, eff. 10-1-75; am. (4) (a) 4. d. and figures 13, 14 and 15, Register, March, 1977, No. 255, eff. 4-1-77; renum. (2) to be (2) (a) and am., cr. (2) (b), am. (4) (a) 3 and 4, renum. (4) (a) 4.c. to be (4) (b) and am., cr. (4) (c), (e) and (f), renum. (4) (a) 4.a. to be (4) (d), Register, April, 1978, No. 268, eff. 5-1-78; am. (4) (a) 2., Register, October, 1982, No. 322, eff. 11-1-82.

NR 112.18 Well construction equipment. (1) **ADEQUACY.** Every registered well driller shall be adequately equipped or shall have ready access to adequate equipment to enable him to fully comply with all regulatory requirements applicable to any construction undertaken by him.

(2) **IDENTIFICATION.** The well driller's name and current permit number shall be conspicuously displayed on every well construction job, preferably on his equipment, but may be displayed on a temporary sign.

History: Cr. Register, June, 1975, No. 234, eff. 10-1-75.

NR 112.19 Concrete and grout mixtures. (1) **CONCRETE AGGREGATE AND MIXTURE.** (a) Concrete for use in construction of wells, well platforms and pump floors shall be made of clean, hard, tough and durable aggregates. The maximum diameter of aggregate particles shall not exceed 1/5 of the minimum width between forms. The fine aggregate, or sand, should be separated from the coarse aggregate by means of ¼ inch screen and the ratio of coarse aggregate to fine aggregate shall be about 1½ to 1, by volume. This ratio shall not exceed 2 to 1 nor be less than 1 to 2. From 30 to 70 % of the sand passing a ¼ inch screen should be retained on a number 30 sieve.

(b) In proportioning concrete, sufficient sand and coarse aggregate shall be mixed to make approximately 3 cubic feet of mixed aggregate. To this aggregate shall be added 1 sack of cement and 5½ gallons of water. If the aggregate is wet, the water ratio shall be no more than 5 gallons per sack of cement. The consistency shall be wet enough to permit easy placement without an excess of water.

(2) **CONCRETE GROUT.** The mixture shall consist of cement, sand and water in the proportion of one bag of cement (94 pounds), and an equal volume of dry sand, and 5 to 6 gallons of clean water. It may be used in lieu of cement grout in the dry portion of a hole but only if applied through a conductor pipe extending to the point of placement and department approval has been received pursuant to NR 112.04.

(3) **NEAT CEMENT GROUT.** Neat cement grout shall consist of cement and water in the proportion of one bag of cement (94 pounds) to 5 to 6 gallons of clean water. Approved ingredients to increase fluidity, reduce shrinkage or control time of set may be used in a grout mixture.

History: Cr. Register, June, 1975, No. 234, eff. 10-1-75.

NOTE:

No overflow provision - only practical if possible to stop flow without escape of water upward outside of casing.

Approved sanitary well seal - Solid top plate type with expandable rubber gasket.

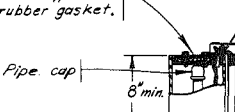

Electrical conduit

Electrical conduit

Ground surface

Well casing

Distance shall comply with NR 112.07

NOTE:

Installation of a locking device on the adapter pull pipe may be needed to resist the upward thrust due to natural pressure.

Braze the port opening shut - watertight or obtain spool without an opening or brazed shut.

Any spool type approved adapter.

Sketch is schematic, with no attempt to illustrate proper support that would identify the adapter with a manufacturer's product.

Braze bushing in place for locking fitting for emergence of electrical wiring or obtain spool with wire already sealed in the port opening.

Here or here Only acceptable check valve location is in the well.

Submersible pump

Dwelling

Electrical control box

Pressure Tank

Sampling faucet

Figure 18. Pump Installation for Flowing Artesian Well using an Approved Pitless Adapter and Submersible Pump with no Overflow Provision.

practical if possible to stop flow without escape of water upward outside of casing.

Approved sanitary well seal - Solid top plate type with expandable rubber gasket.

Pipe cap
Ground surface
8 min.

Well casing
Distance shall comply with NR 112.07

NOTE:
Installation of a locking device on the adapter pull pipe may be needed to resist the upward thrust due to natural pressure.

Braze the port openings shut watertight. Preferably order without cores.

Any spool type approved adapter.

Sketch is schematic, with no attempt to illustrate proper support that would identify the adapter with a manufacturer's product.

Plain drop pipe (No pump in well)

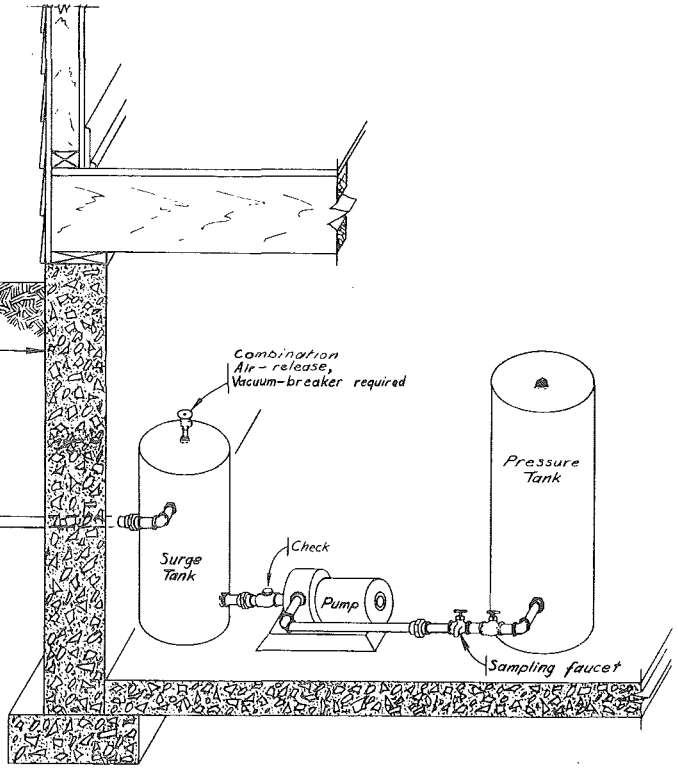
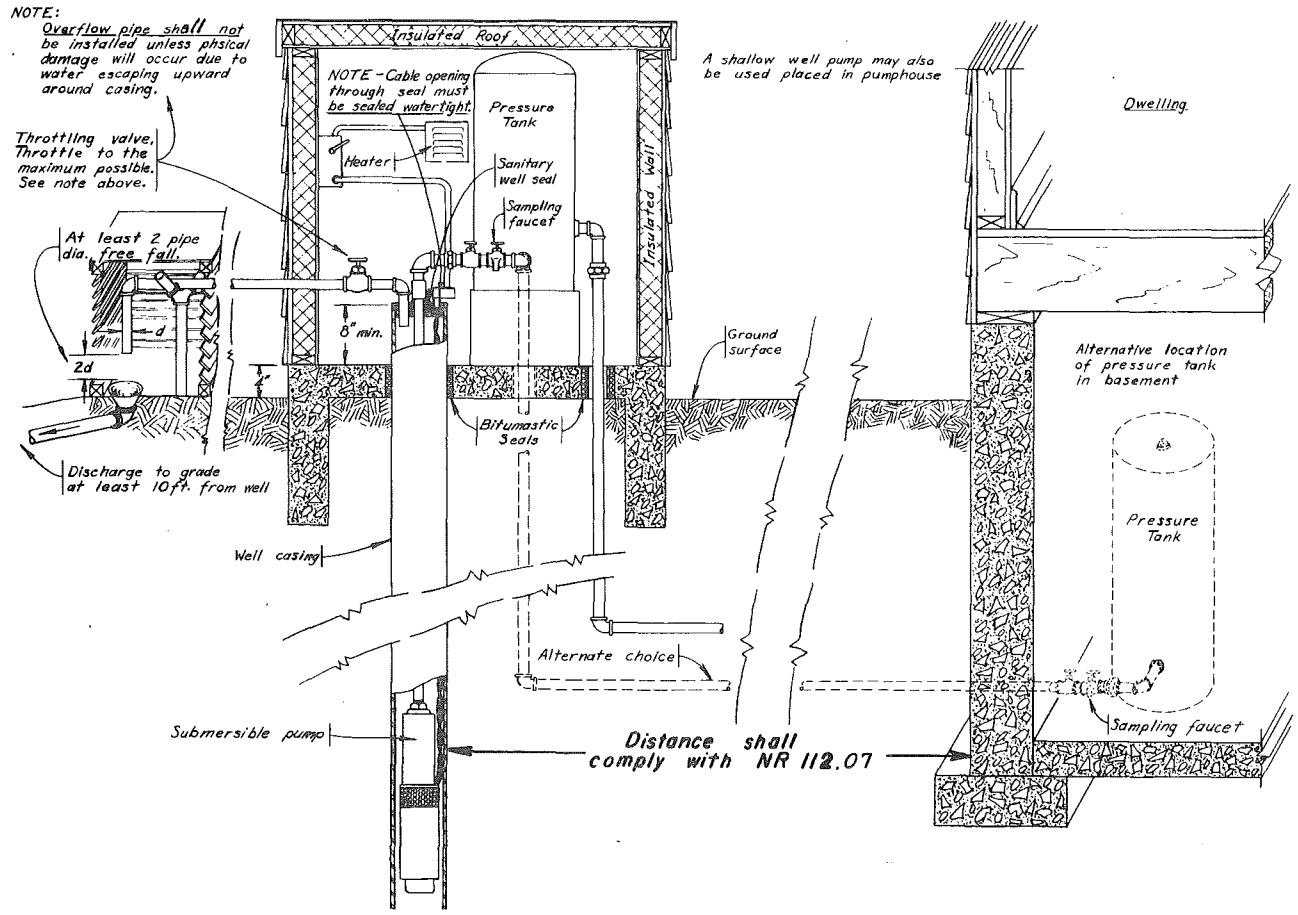

Figure 19. Pump Installation for Flowing Artesian Well using an Approved Pitless Adapter, Surge Tank and Booster Pump with no Overflow Provision.



E:
Well overflow pipe shall only be installed if physical damage would otherwise occur due to water escaping upward around the casing or to prevent freezing of the top of the well, should it not be desired to construct an insulated structure over the well. However, the insulated structure would be preferred for frost protection, should the overflow pipe not be necessary to prevent physical damage to the well.

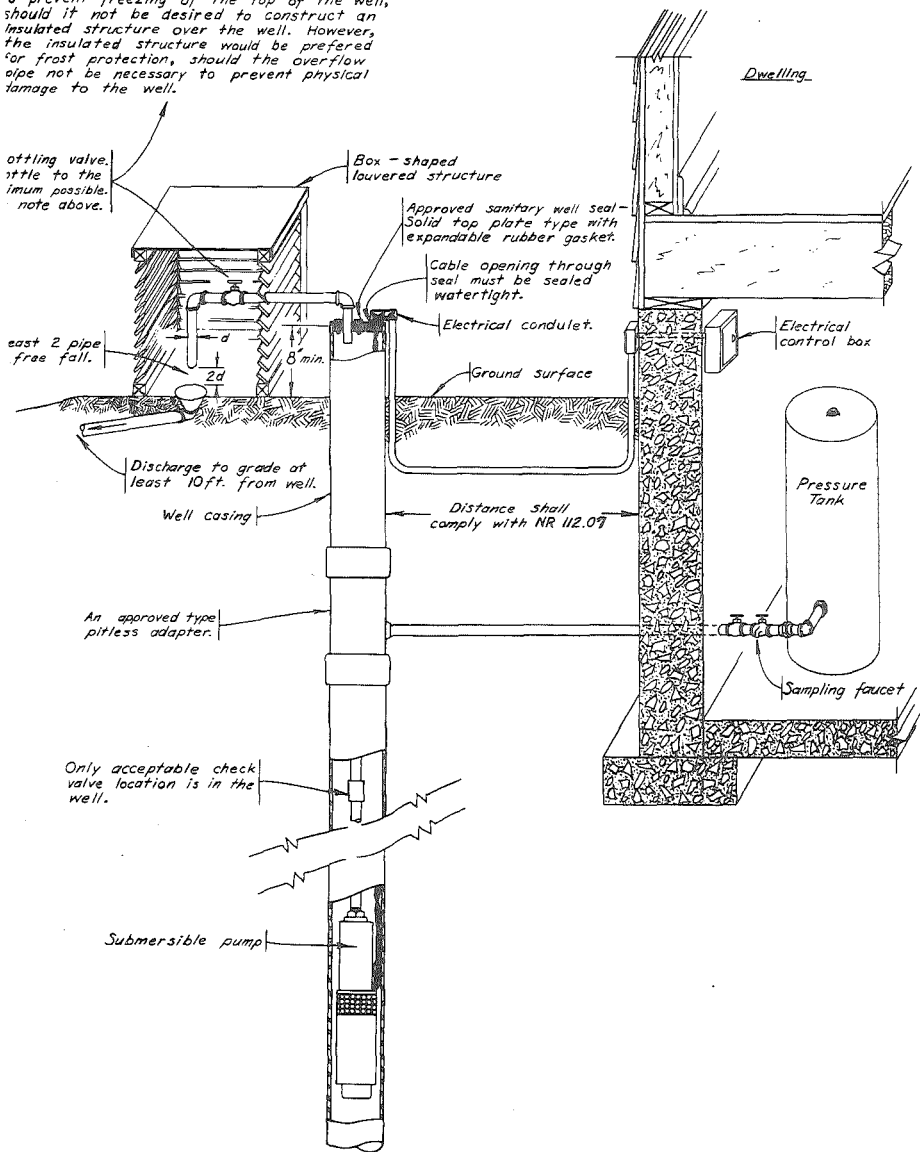

Figure 21. Pump Installation for Flowing Well using an Approved Pitless Adapter and Submersible Pump and Overflow Provision, if necessary.

NOTE:

Well overflow pipe shall only be installed if physical damage would otherwise occur due to water escaping upward around the casing or to prevent freezing of the top of the well, should it not be desired to construct an insulated structure over the well. However, the insulated structure would be preferred for frost protection, should the overflow pipe not be necessary to prevent physical damage to the well.

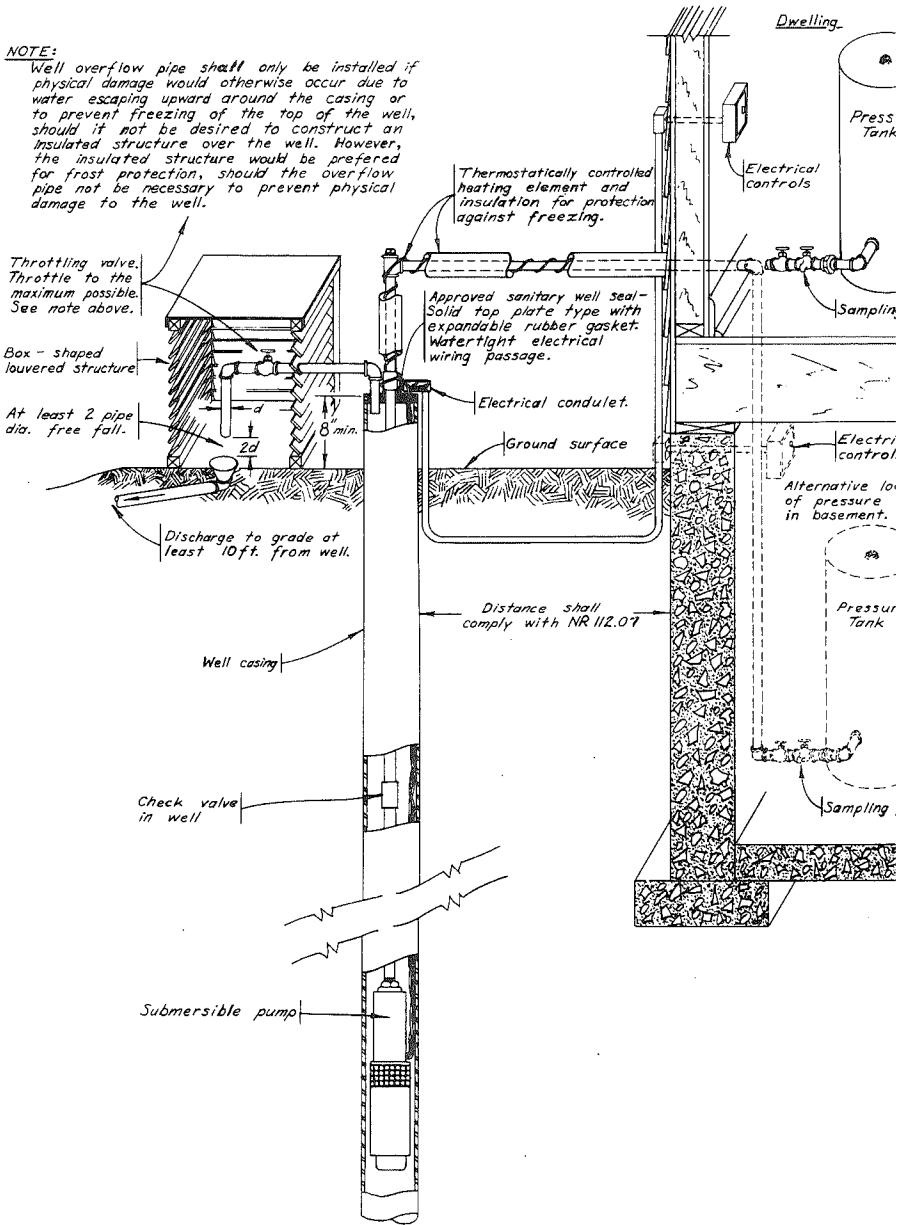

Figure 22. Pump Installation for Flowing Well Using a Submersible Pump and Above-Ground Discharge and Overflow Pipe, if necessary.

Approved sanitary well seal -
Solid top plate type with
expandable rubber gasket.

Pipe cap
Ground surface
8 min.

NOTE:
Installation of a locking
device on the adapter
pull pipe may be needed
to resist the upward
thrust due to natural
pressure.

Braze the port openings
shut watertight. Preferably
order without cores.

Any spool type
approved adapter.

Sketch is schematic, with no
attempt to illustrate proper
support that would identify
the adapter with a manu-
facturer's product.

Well casing
Distance shall
comply with NR 112.07

Plain drop pipe
(No pump in well)

NOTE:
Overflow pipe shall not be
installed unless physical
damage will occur due to
water escaping upward
around casing.
Undoubtedly, an overflow will
contribute moisture to the basement air.

Combination air - release
Vacuum-breaker only necessary
if overflow can and will be
omitted

Throttling valve.
Throttle to the
maximum possible
see note above.

Floor drain - if cast
iron pipe, must be at
least 8ft. from well.
Other pipe material,
drain must be at least
25 ft. from well.

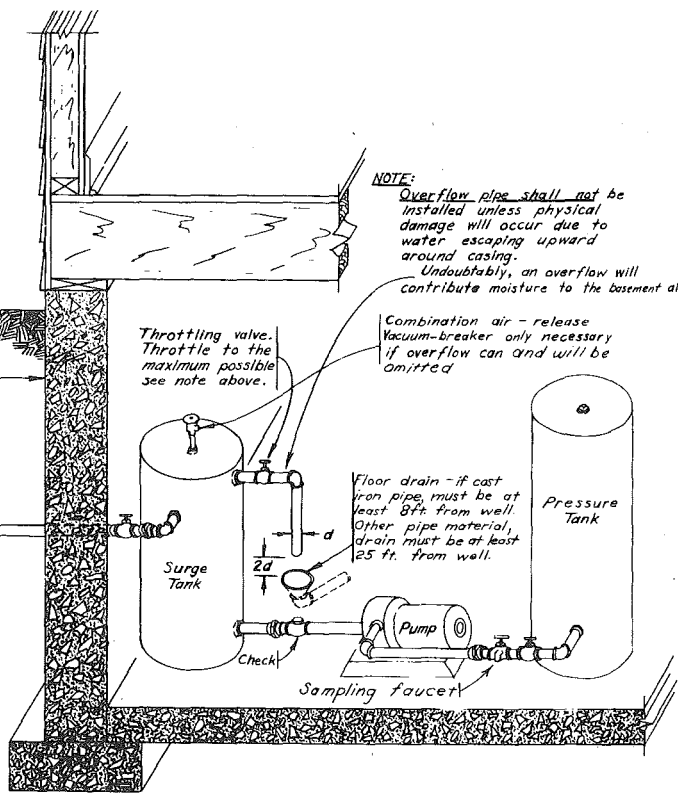
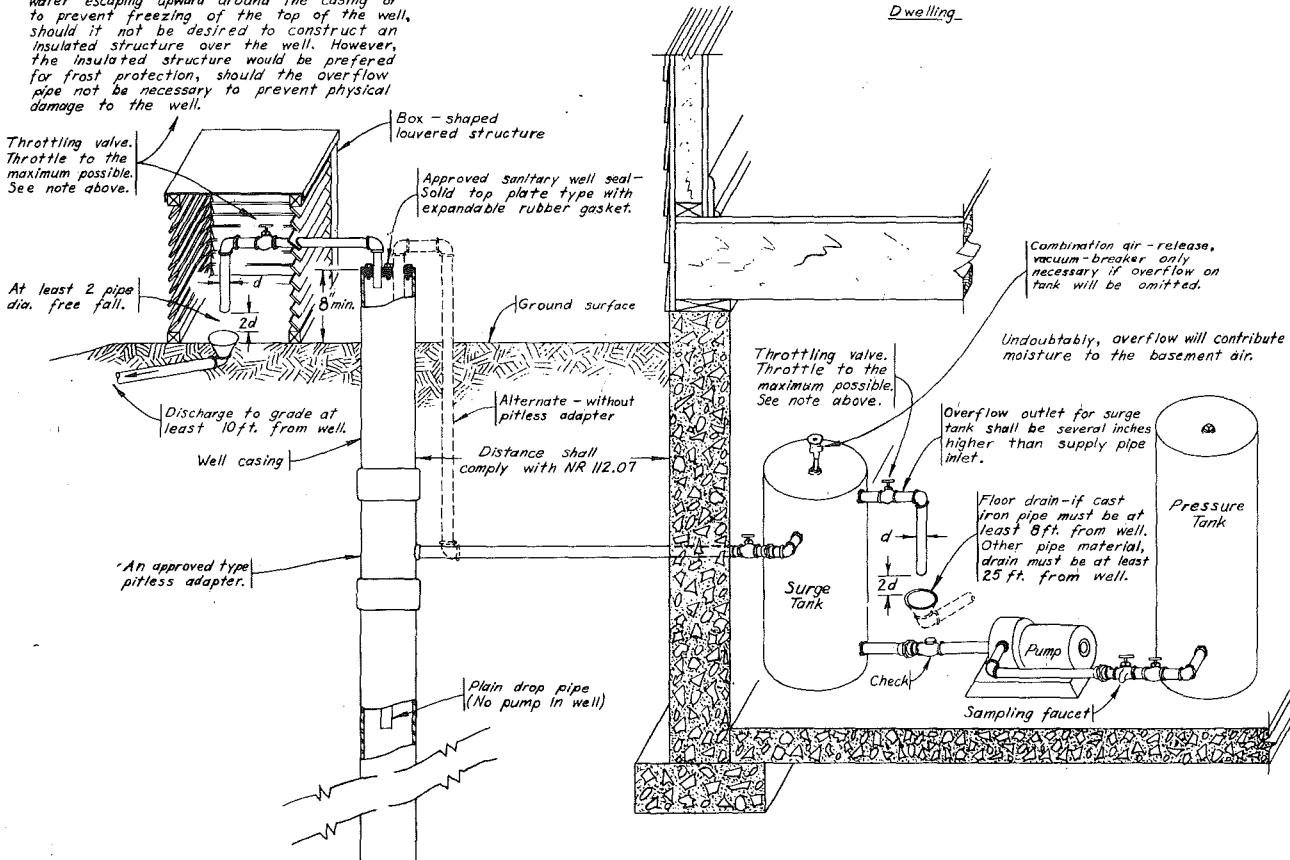

Figure 23. Pump Installation for Flowing Well Using an Approved Pitless Adapter, Surge Tank and Booster Pump, with Overflow Provision off the Surge Tank, if necessary.

NOTE:

Well overflow pipe shall only be installed if physical damage would otherwise occur due to water escaping upward around the casing or to prevent freezing of the top of the well, should it not be desired to construct an insulated structure over the well. However, the insulated structure would be preferred for frost protection, should the overflow pipe not be necessary to prevent physical damage to the well.



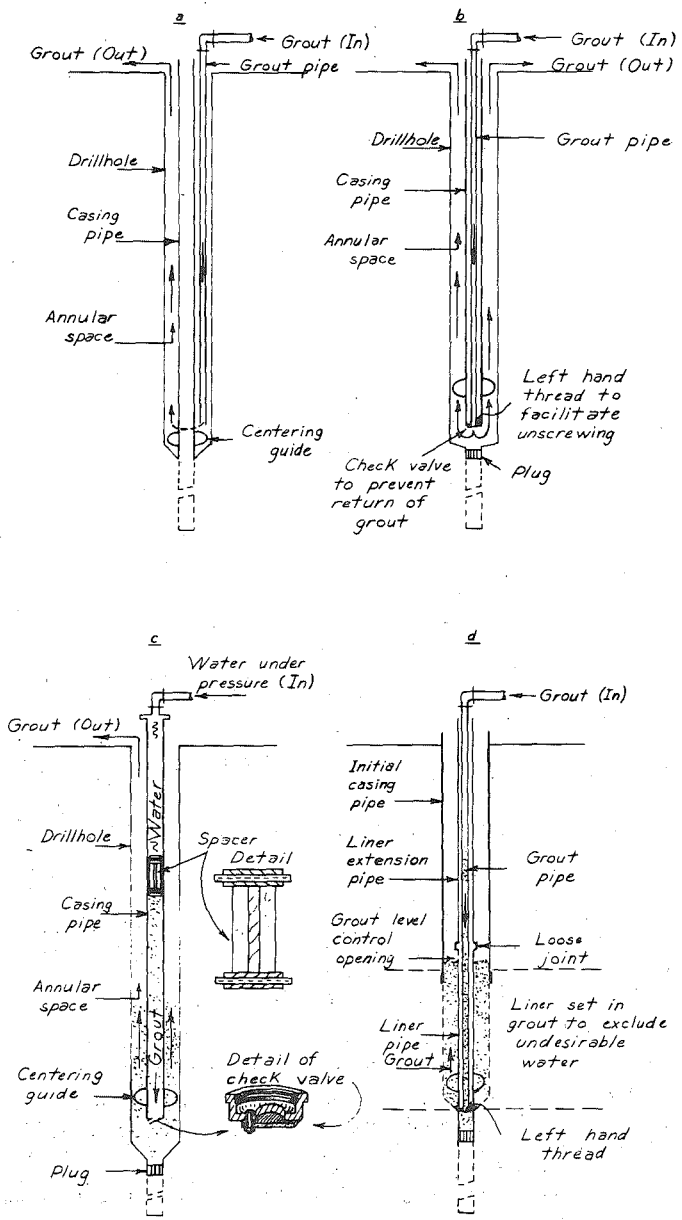

Figure 25. Arrangements for Grouting Annular Space.

NR 112.20 Well disposal of pollutants. The use of any well for disposal of solid wastes, sewage or surface or wastewater drainage is prohibited. (Note: See NR 112.03 (51) for definition of sewage.)

History: Cr. Register, June, 1975, No. 234, eff. 10-1-75.

NR 112.21 Abandonment of wells. (1) **METHODS.** When a well is permanently abandoned the owner thereof shall remove from the well any debris, pump, piping, unsealed liners or other obstruction that may interfere with sealing operations and fill and seal the well in such manner as to prevent it from acting as a channel for contamination or vertical movement of water by using one of the following methods:

(a) *Drift or other unconsolidated formation wells.* Such wells shall be filled entirely with concrete or clean clay slurry, in which latter case a concrete plug at least 20 feet thick shall be poured at the top of the well. Inner ungrouted well casing and screen shall be removed from gravel-pack wells prior to filling. The top 7 feet of curbing shall be removed prior to filling dug or bored wells.

(b) *Limestone formation wells.* Preferably any limestone strata shall be filled entirely with concrete. As an alternate, layers of concrete and gravel or stone aggregate may be used except that the top 20 feet of the rock formation and the entire cased portion shall likewise be filled with concrete. An exception to filling the cased portion with concrete under the alternate method may be made where the well casing is set in rock and sealed in place with cement grout. In such a case, a concrete plug at least 40 feet thick shall be placed extending at least 20 feet above and below the bottom of the casing. The remainder of the cased portion up to 20 feet from the surface may be filled with gravel, crushed rock, sand or clay slurry, provided that the top 20 feet shall also be filled with concrete.

(c) *Sandstone formation wells.* Preferably any sandstone formations shall be filled entirely with concrete. As an alternate, disinfected sand or pea gravel may be used except that the top 20 feet of the formation and the entire cased portion in this alternate method shall likewise be filled with concrete. An exception to entirely filling the well casing with concrete may be made where the well casing is set in rock and sealed in place with cement grout. In such a case, a concrete plug at least 40-feet thick shall be placed extending at least 20 feet above and below the bottom of the casing. The remainder of the cased portion up to 20 feet from the surface may be filled with pea gravel, sand or clay slurry, provided that the top 20 feet shall also be filled with concrete.

(d) *Shale rock, granite and quartzite formation wells.* The same procedure as with limestone formation wells shall be used.

(e) *Mixed formation wells.* Drift or other unconsolidated formations, limestone, sandstone, shale, granite and quartzite strata shall be filled in compliance with NR 112.21 (1) (a), (b), (c) and (d). Where the alternate methods to filling the well entirely with concrete are selected, concrete or concrete grout plugs at least 40 feet in depth, extending at least 20 feet above and below the point of surface contact between every recognized different geologic formation shall be provided.

(f) *Flowing wells.* In filling flowing wells the flow shall be confined by extending well casing pipe, if possible, and the well shall be filled with

materials in accord with applicable preceding subsections or with cement grout applied by a pressure method.

(g) *Sealing procedure restriction.* Filling material for nonflowing wells shall be applied through a conductor pipe except that when practical a dump bailer may be used. When concrete is placed under water by a conductor pipe, the bottom end of the conductor pipe shall be submerged in the concrete at all times.

(2) **TEMPORARY ABANDONMENT.** When a well is temporarily removed from service the top shall be sealed with a watertight threaded or welded cap or it shall be filled with clean clay slurry.

(3) **REPORT TO DEPARTMENT.** A report shall be made to the department by the owner of every well which has been permanently abandoned or temporarily removed from service. Such report shall include a detailed description of location, construction and geologic features and method of sealing.

History: Cr. Register, June, 1975, No. 234, eff. 10-1-75.

NR 112.22 Cooperation with the department. Well drillers and pump installers shall, when requested by the department, do the following:

(1) Give at least 48 hours notice to the department of the day and date upon which any well under construction, or part thereof, or any installation of pumping equipment, or part thereof, by such driller or installer, or any employe or agent thereof, will be completed.

(2) Assist the department in ascertaining the size, depth and character of the construction for any such well or the character of the installation of the pumping equipment.

(3) Assist the department in obtaining and determining the character of the samples of water from any such well.

(4) Assist the department in conducting necessary tests.

(5) Provide such other information as may be required by the department in order to determine if such well has been constructed or any equipment has been installed in accordance with the provisions of this chapter or with approved comparable construction.

History: Cr. Register, June, 1975, No. 234, eff. 10-1-75.

NR 112.23 Standards for existing installations. (1) **LOCATION AND CONSTRUCTION.** Each existing water supply system shall be viewed as an individual unit and its safety shall be determined on the basis of its location and construction.

(a) *Location.* The location shall reasonably conform to the provisions of s. NR 112.07 or the separation requirements in effect at the time of the well or pump installation, or, if more recent, at the time of installation of any contaminant source.

(b) *Construction.* The underground construction shall be in reasonable compliance with ss. NR 112.08 and 112.085 as to depth and type of casing and curbing or with the minimum requirements in effect at the time of construction. Well pits, pump pits, pressure-tank pits, pressure-

1953

tank access pits and subsurface pumprooms adjoining basements existing prior to April 10, 1953 shall meet the following requirements:

1. The floor and roof shall be crack-free poured concrete having a thickness of at least 4 inches. The walls shall be 6-inch thick watertight poured concrete or equivalent construction unless the pit or pumproom has a history of being continuously dry in which case masonry walls of concrete block, brick or stone with mortared joints shall be acceptable. A 3-inch thick concrete facing on substantial masonry walls shall be accepted as equivalent wall construction. The junction of walls and floors shall be watertight. The roof or deck shall be above the ground surface.
2. The well pit shall be fitted with a manhole opening having a raised curbing edge at least 4 inches thick and at least 4 inches higher than the pit roof. A substantial, watertight, overlapping, tight-fitting cover with skirted sides shall be provided for the manhole. The cover preferably shall be constructed with welded sheet steel but it may be constructed out of lumber covered with sheet metal or tin.
3. The subsurface pumproom shall either have a manhole as in subd. 2., or a section of well casing pipe with diameter equal to or greater than the well casing, installed directly above the well casing and sealed with an approved type well seal or cap.
4. Where practical the pit shall be drained by a separate watertight, metal gravity type drain discharging to the ground surface, such drain being constructed either with steel or with cast iron pipe. When such a drain is not installed, a watertight sump shall exist. If ground water gains access to the pit through the floor or walls, the pit shall be abandoned and filled after extension of the well casing with an acceptable joint. A subsurface pumproom adjoining a basement may be drained to the basement provided the basement in turn is adequately drained. Otherwise a partition wall at least 1 foot high in the pumproom entrance and separate drainage facilities similar to that required for separate pits shall exist. No pit drain or sump pump discharge pipe shall be connected directly with any sewer, other drain or plumbing system.
5. The well casing shall terminate at least 6 inches above the floor of a pit or of a subsurface pumproom and be provided with an approved type sanitary well seal with metal top and bottom plates, a rubber gasket and draw/bolts.
6. Well pit vent pipes, if used, shall be 2-inch diameter galvanized steel pipes located in opposite corners, one pipe to extend to within 1 foot of the pit floor and the other to extend only through the pit roof. The upper end of each vent pipe shall terminate with a return bend with a screened outlet.

(2) PUMP INSTALLATION. Pump installations existing prior to April 10, 1953, shall conform to the following requirements. Existing installations made after that date shall conform to the requirements in effect at the time of the installation. When a new pump installation is necessary, it shall comply with the current requirements of this chapter.

(a) *Offset units.* For installations completed after April 10, 1953, suction piping shall be enclosed in a conduit in accordance with s. NR 112.14 (2) (c). If nonpressure conduit pipe is used to enclose suction, submersible or jet pump piping, it shall be a minimum of new 4-inch

diameter or larger diameter pipe meeting the specifications of s. NR 112.085 (1) or, for thermoplastic cased wells, with s. NR 112.085 (2). Such conduit may terminate in a basement if the elevation of the pipe is at least 2 feet above the basement floor and the basement is in active use and is not subject to flooding. For installations completed prior to April 10, 1953, the suction line of an offset shallow well pump or the piping of an offset jet pump shall be contained in a sealed conduit between the well and a basement, be connected to the well through a stuffing box or short sealed conduit in a conforming well pit, or be connected to the well with a pitless adapter approved prior to April 10, 1953. Nonpressure conduit shall enter the basement so that the bottom of the conduit is at least 6 inches above the basement floor.

Note: It is recommended that the pump impeller or cylinder of pump units located in basements be located above the ground level or be at least 2 feet above the floor.

(b) *Pit setting.* A deep well reciprocating, turbine or jet pump and set-length type force pump located in a conforming pit shall be so installed as to permit the sealing of the top of the well with an approved type watertight sanitary well seal with gasket, or an equivalent watertight connection with the pump. Any well vent pipe shall extend to the ceiling of the pit and terminate with a return bend and shall have a screened outlet.

(c) *Hand type pumps.* Hand type pumps may be continued in service provided that the pump base flange rests upon a casing flange and the flanges are separated by a gasket. The casing flange must be placed at least 6 inches above the ground or a concrete pump platform. If water is pumped from a hand pump to a reservoir, the piping attachment to the pump shall be made with permanent pipe fittings. Whenever a reservoir exists, the discharge pipe from the pump shall enter the reservoir in a watertight manner through that portion of the structure extending above the ground grade unless a subsurface reservoir supply line is connected to the well by an approved type pitless adapter for a submersible or deep well reciprocating pump and the supply line can be maintained under a positive head of at least 5 feet. The supply pipe in such case shall terminate at or no more than a few inches above the bottom of the reservoir and a float control switch or low and high water level electrical pump-control rods shall exist. Any check valve shall exist only in the portion of the pump discharge pipe located within the well.

(d) *Reservoirs.* 1. The roof of any existing reservoir shall be crack-free, reinforced, poured concrete having a thickness of at least 5 inches. The floor of the reservoir normally shall be crack-free poured concrete at least 4 inches thick. The walls of the reservoir shall be crack-free, reinforced, poured concrete at least 5 inches thick or equivalent construction. A 3-inch thick reinforced concrete facing on substantial masonry walls may be accepted as equivalent wall construction. Exception to this requirement will be made where masonry with mortared joints has been used in the construction of the walls, or roof or both and the masonry is crack-free.

2. The manhole curbing shall extend at least 12 inches above the ground grade unless the reservoir roof terminates above the ground grade, in which case the curbing shall terminate at least 6 inches above the reservoir roof. The manhole shall be provided with a tight-fitting, overlapping cover with a minimum of 3-inch wide skirted sides. The

NR 112

manhole cover shall preferably be constructed of welded sheet steel but one constructed of concrete will be acceptable. The manhole cover shall be fitted snugly over the manhole curbing so as to prevent entrance of insects and vermin into the reservoir.

3. Any reservoir overflow pipe shall be located just under the roof of the reservoir and entirely above the ground grade and terminate with a down-turned pipe with a screened outlet at a point at least 12 inches above the ground grade. If an existing overflow pipe is totally buried between the reservoir and its outlet, it shall be eliminated by properly sealing the pipe with concrete back to the reservoir.

4. The reservoir location shall be equivalent to that required for an existing well.

(3) **INSPECTIONS.** Inspections of existing installations will be made for problem water supplies and also those requiring certification when staff are available to provide such service.

History: Cr. Register, June, 1975, No. 234, eff. 10-1-75; am. (1) (a), (b) (intro.), (2) (intro.) and (a), Register, October, 1982, No. 322, eff. 11-1-82.

NR 112.24 Severability. Should any section, paragraph, phrase, sentence, clause or word of this chapter be declared invalid or unconstitutional for any reason, the remainder of this chapter shall not be affected thereby.

History: Cr. Register, June, 1975, No. 234, eff. 10-1-75.

NR 112.26 Well and pump installation approvals. (1) **HIGH CAPACITY WELL APPROVALS.** (a) No wells shall be constructed, reconstructed, rehabilitated, installed or operated to withdraw water from underground sources for any purpose where the operating capacity, either singly or in the aggregate with that of other wells on the property will be in excess of 70 gallons per minute, unless the owner, lessee, or any other person having a possessory interest obtains a written approval from the department. In any case involving an application by a person other than the owner of the subject property the owner shall join in the application.

(b) If the department finds that a proposed high capacity well will reduce the availability of groundwater to any public utility as defined by s. 196.01, Stats., it may deny approval or grant a limited approval under which it imposes such conditions as to locations, depth, pumping capacity or rate of flow and ultimate use so that the water supply of any public utility will not be impaired.

(c) Any well constructed pursuant to this subsection shall be constructed in accordance with NR 112.08.

(d) Approval applications shall provide the following basic information:

1. Description of property, including any contiguous property owned or leased by the applicant.

2. Property owner, giving names of partners, if a partnership, and officials if a corporation.

3. Proposed well owner, giving name of lessee if lessee is to construct well.

4. Proposed well operator, giving name of lessee if lessee is to operate well.

5. Existing well locations on property.

6. Description of designs of existing wells and pump installations on same and contiguous property owned or leased by the applicant.

Next page is numbered 313

7. Estimate of current water use from each well and proposed water use from each well following completion of the proposed well or wells or pump installation or installations, giving type of use.

8. Plan and specifications of proposed well construction indicating geologic formations expected to be encountered; drillhole diameters and depths; type of drilling equipment to be used; well casing pipe and liner pipe wall thickness, weight ASTM or API specification and grade and type of end finish; proposed area of grouting; material to be used to seal the annular space surrounding the well casing pipe and liner pipe; and the proposed method of grouting.

9. Plan of proposed pump installation, including interconnection of the pump discharge pipe with water system, pressure or storage tanks, elevated tanks, reservoirs, booster pumps, metering and proposed means for measuring well water levels and sampling.

10. Plan of property showing the location of buildings, wells, and possible contamination sources such as sewers, drains, septic tanks, waste disposal system units, buried fuel storage tanks.

11. Map giving location of nearest public utility wells.

12. Map giving location of private wells on different properties within 2,500 feet. Where the department determines that the possibility of interference to neighboring wells may occur at a greater distance it may require additional information on private well locations.

13. Alternative sources of supply.

(e) If the original applicant relinquishes control of the well, a new approval shall be obtained from the department by lessee or new owner for continuation of operation of a high capacity water system.

(f) Emergency approval may be granted by the department where fire hazard, imminent crop damage, or other similar emergency requires it when it has been determined that such well will not adversely affect the availability of ground water to a public utility. The owner, lessee, or any other person having a possessory interest shall obtain, within 60 days from the issuance of an emergency approval under this subsection, written approval from the department for continued operation of any well constructed pursuant to this subsection. The applicant for emergency approval shall provide information on the proposed well location, construction, reconstruction, rehabilitation, reactivation or pump installation and proposed rate of operation.

(g) Approval by the department does not relieve the applicant of any liability which may result from injury or damage suffered by any person upon operation of the well.

(h) The department may require the installation of metering and water level measuring equipment.

(i) The owner, lessee or any other person who owns or operates a high capacity water supply at any time shall submit on forms supplied by the department, monthly pumpage and well water level reports, as requested by the department.

(j) Failure of applicant to comply with any conditions of approval or the construction and operation of any well in violation of the rules of the department shall void said approval.

(k) The department shall retain jurisdiction over all wells approved under this section and may limit or deny pumping if changed circumstances warrant such action for protection of a public utility.

(1) Any well driller, pump installer or contractor shall independently verify the approval of the department prior to initiation of construction, reconstruction, rehabilitation, installation, or operation of a high capacity well. Failure to verify the existence of such approval shall be a violation of this chapter.

(2) SCHOOL WATER SUPPLY APPROVALS. (a) No well shall be constructed, reconstructed, rehabilitated, installed or operated for a school water supply unless the school district or other owner obtains a written approval from the department.

(b) Any well constructed pursuant to this section shall be constructed in accordance with NR 112.08.

(c) Plans and specifications for any wells to be constructed and for any pumps to be installed pursuant to this subsection shall be submitted in duplicate by a registered professional engineer or registered driller, in case of wells and by a registered professional engineer or registered pump installer in the case of pumps.

(d) Approval applications shall provide the following basic information:

1. Name of school.
2. Ownership of school and mailing address.
3. Location of school.
4. Name and address of school clerk and school officials, superintendent or director, etc.
5. Number of classrooms.
6. Number of pupils currently and ultimately.
7. Plan and specifications of proposed well construction indicating geological formations expected to be encountered; drillhole diameters and depths; type of drilling equipment to be used; well casing pipe and liner pipe wall thickness, weight, ASTM or API specification and grade and type of end finish; proposed area of grouting; material to be used to seal the annular space surrounding the well casing pipe and liner pipe; and the proposed method of grouting.
8. Description of existing wells and pump installations.
9. Plan and specifications for the pump installation including interconnection of the pump discharge pipe with the water system pressure or storage tanks, reservoirs, booster pumps, metering and proposed means for measuring well water levels and sampling.

10. Plan of property showing the location of the buildings, wells and possible pollution sources such as sewers, drains, septic tanks and sewage disposal units and buried fuel oil tanks.

11. Computations made to determine the quantity of water necessary to adequately serve the school at its ultimate capacity.

(e) Approval by the department does not relieve the applicant of any liability which may result from injury or damage suffered by any person upon operation of the well.

(f) The department may require the installation of metering and water level measuring equipment to obtain pumpage and water level data.

(g) The school shall submit on forms provided by the department monthly pumpage and well water level reports as requested by the department.

(h) Prior approval is required for any proposed installation of chemical treatment equipment in any school water system.

(i) Failure of school to comply with conditions of approval of the construction and operation of any well in violation of this chapter shall void the approval.

(j) Any well driller, pump installer or contractor shall independently verify the approval of the department prior to initiation of construction, reconstruction, rehabilitation, installation or operation of a school water system well. Failure to verify the existence of such approval shall be a violation of this chapter.

(3) SEWAGE TREATMENT PLANT WATER SYSTEM APPROVALS. (a) No well shall be constructed, reconstructed, rehabilitated, installed or operated for a sewage treatment plant unless the municipality, sanitary district or private owner obtains a written approval from the department.

(b) Any well constructed pursuant to this section shall be constructed in accordance with NR 112.08.

(c) Plans and specifications for any well to be constructed and any pump to be installed pursuant to this subsection shall be submitted in duplicate under the seal of a registered professional engineer.

(d) Approval applications shall provide the following basic information:

1. Ownership.

2. Officials and their addresses.

3. Plan and specification of proposed well construction indicating geologic formations expected to be encountered; drillhole diameters and depths; type of drilling equipment to be used; well casing pipe and liner pipe wall thickness, weight, ASTM or API specification and grade, and type of end finish; proposed area of grouting; material to be used to seal the annular space surrounding the well casing pipe and liner pipe; and the proposed method of grouting.

4. Plan of proposed pump installation, including interconnection of the pump discharge pipe with the water system, pressure or storage tanks, booster pumps and method of protection of the water system from back siphonage of lines supplying hoses for plant wash down or lines supplying water used in disinfection of sewage.

5. Plan of property showing the locations of buildings, wells, sewers (giving types of sewers), manholes and sewage treatment structures.

(e) Approval of the department does not relieve the applicant of any liability which may result from injury or damage suffered by any person upon operation of the well.

(f) Failure of owner to comply with a condition of approval or the construction and operation of any well in violation of the rules of the department shall void said approval.

(g) Any well driller, pump installer or contractor shall independently verify the approval of the department prior to initiation of construction, reconstruction, rehabilitation, installation, or operation of a sewage treatment plant well. Failure to verify the existence of such approval shall be a violation of this chapter.

History: Cr. Register, April, 1978, No. 268, eff. 5-1-78.

NR 112.27 Drinking water standards. Community water systems serving less than 15 living units and non-community water systems shall comply with the drinking water standards contained in Wis. Adm. Code chapter NR 109.

History: Cr. Register, April, 1978, No. 268, eff. 5-1-78.

Appendix

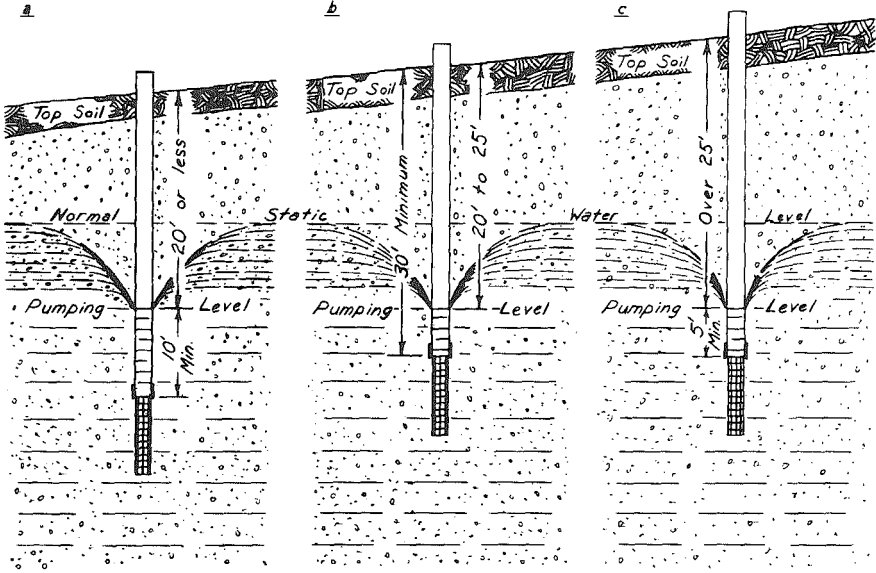

Figure A-1. Construction of Wells in Sand and Gravel with Screens, by Percussion Equipment. See Table 1, a.

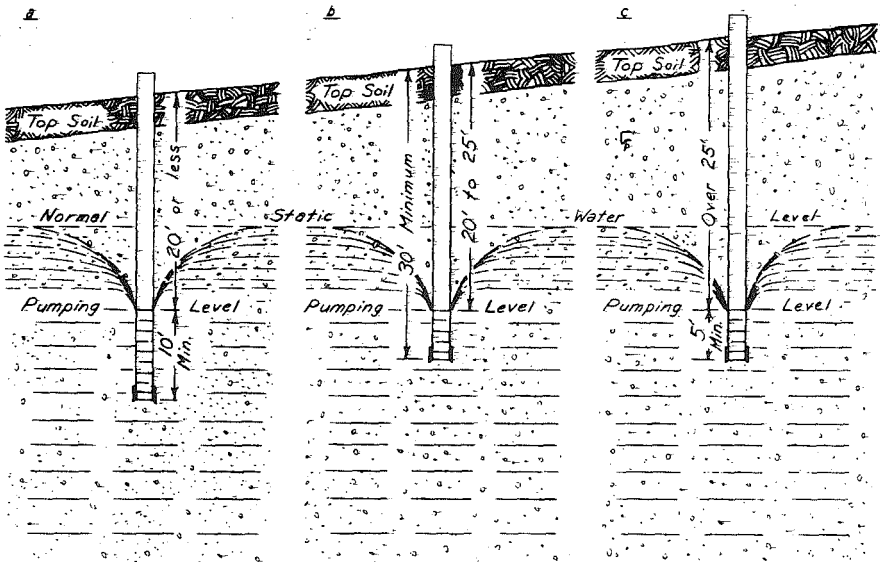

Figure A-2. Construction of Wells in Sand and Gravel without Screens, by Percussion Equipment. See Table 1, a.

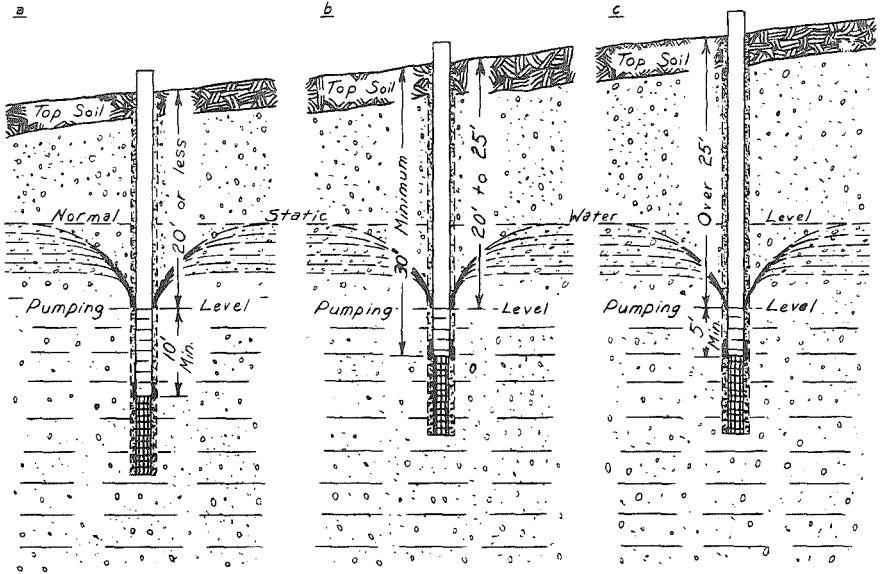

Figure A-3. Construction of Wells in Sand and Gravel with Screens, by Rotary Equipment. See Table 1, a.

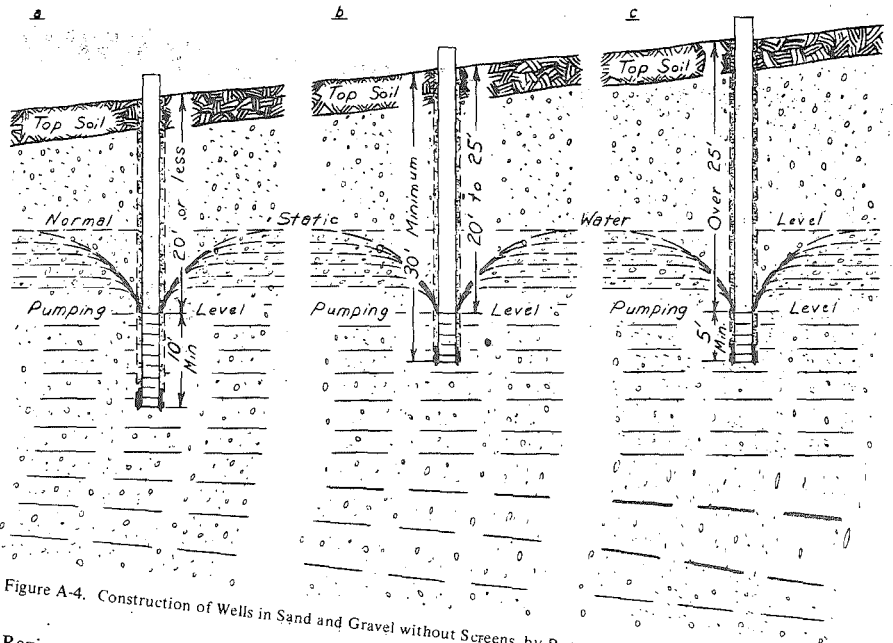

Figure A-4. Construction of Wells in Sand and Gravel without Screens, by Rotary Equipment. See Table 1, a.

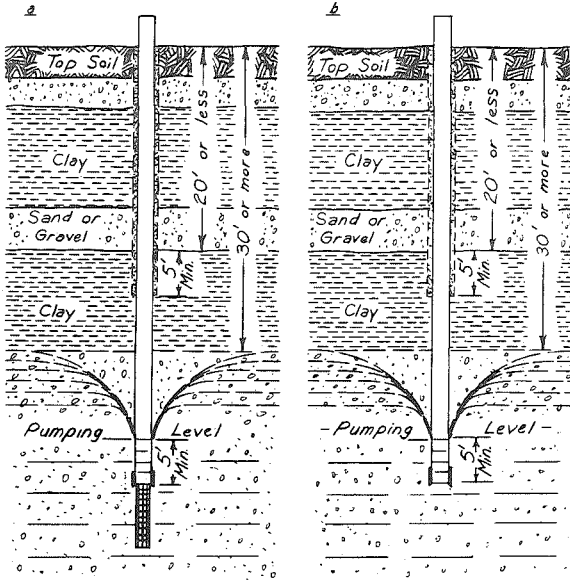

Figure A-5. Construction of Wells Terminating in Sand and Gravel Underlying Clay or Similar Material containing layers of Sand and Gravel, with and without Screens, by Percussion Equipment. See Table 1, b.

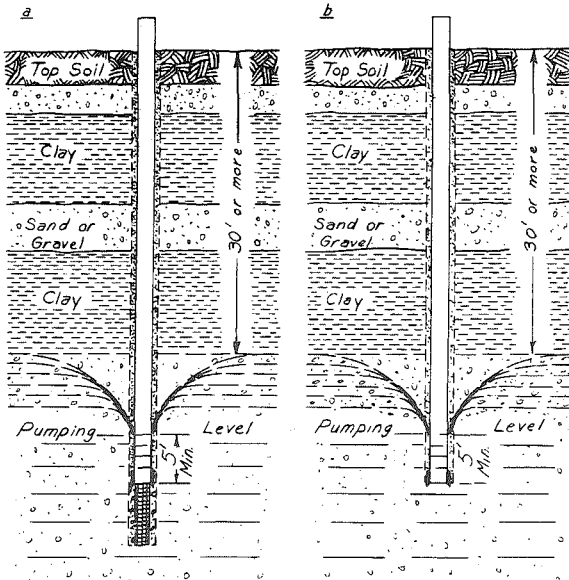

Figure A-6. Construction of Wells Terminating in Sand and Gravel Underlying Clay or Similar Material containing layers of Sand and Gravel, with and without Screens, by Rotary Equipment. See Table 1, b.

NR 112

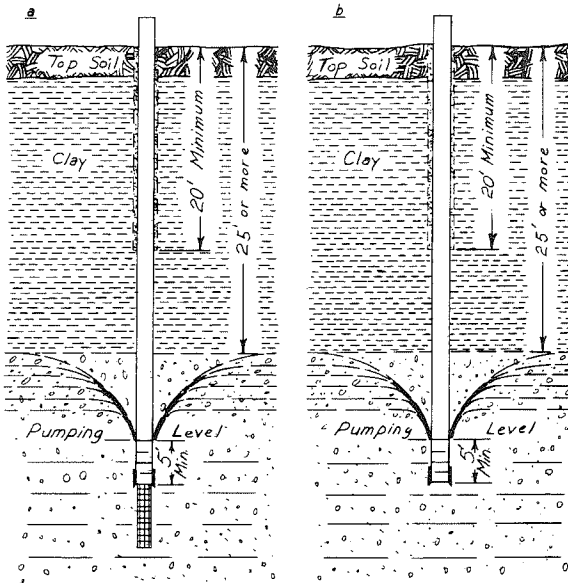

Figure A-7. Construction of Wells Terminating in Sand and Gravel Underlying Clay or Similar Material, with and without Screens, by Percussion Equipment. See Table 1, c.

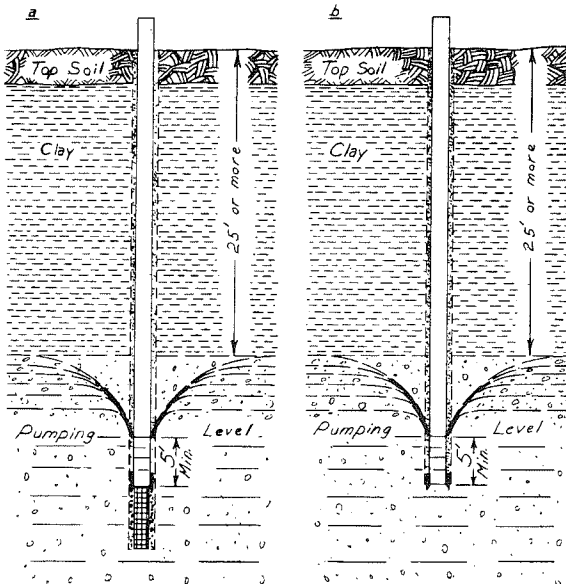

Figure A-8. Construction of Wells Terminating in Sand and Gravel Underlying Clay or Similar Material, with and without Screens, by Rotary Equipment. See Table 1, c.

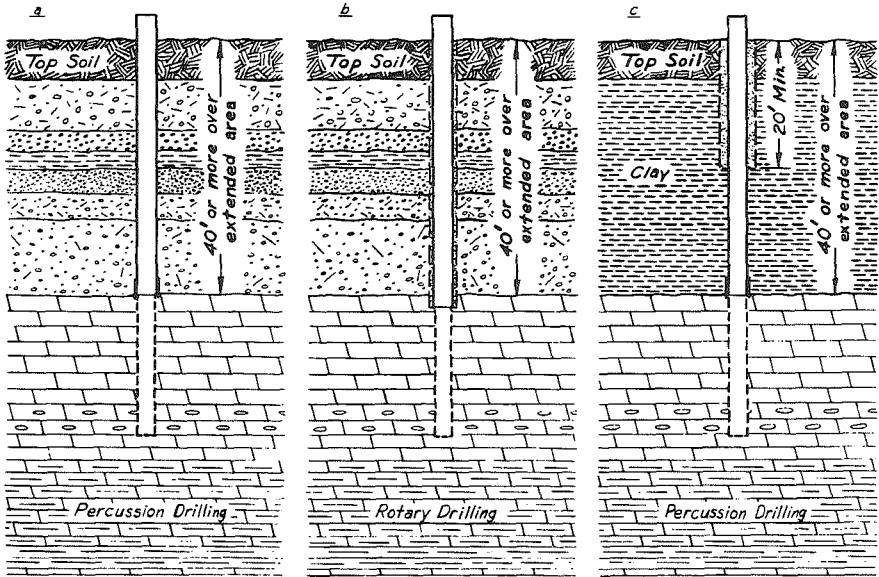

Figure A-9. Construction of Wells Terminating in Limestone Underlying Unconsolidated Materials comprising Mainly Sand and Gravel or Clay or Similar Material, extending to a depth of 40 feet or greater depth. See Table 1, d and e.

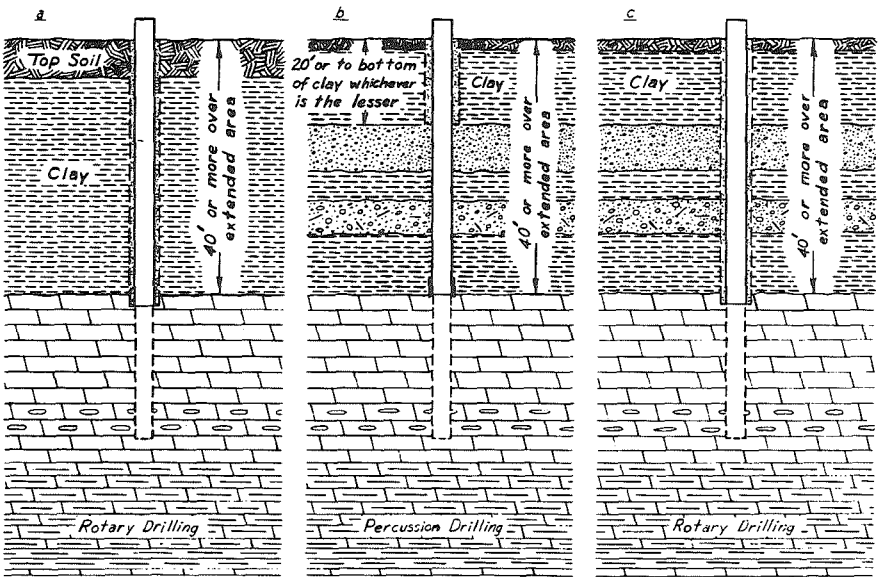

Figure A-10. Construction of Wells Terminating in Limestone Underlying Clay or Similar Materials or such materials with some Sand and Gravel Zones, extending to a depth of 40 feet or greater depth. See Table 1, e.

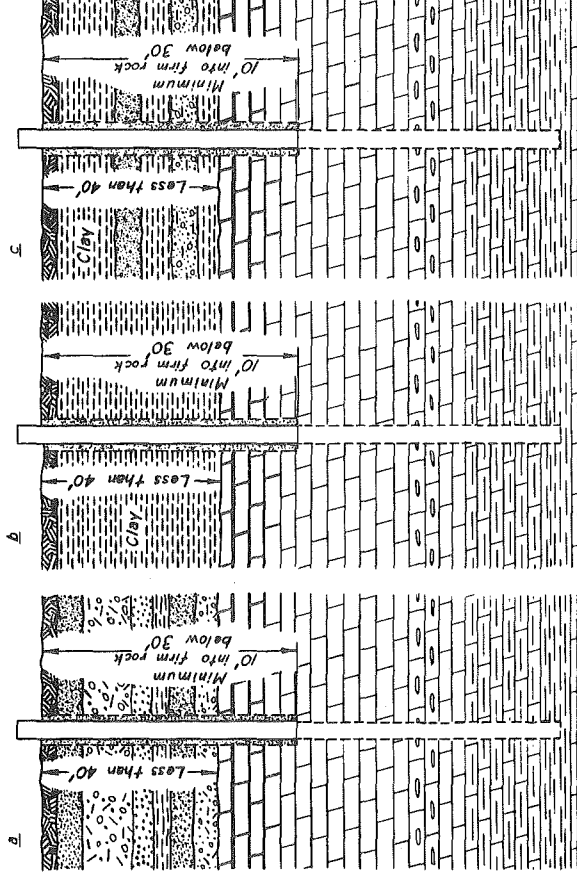

Figure A-11. Construction of Wells Terminating in Limestone Underlying Unconsolidated Materials comprising mainly Sand and Gravel, or Clay or Similar Material or a Mixture of Sand, Gravel and Clay or Similar Material, extending to a depth of less than 40 feet by either Percussion or Rotary Equipment. See Table 1, f.

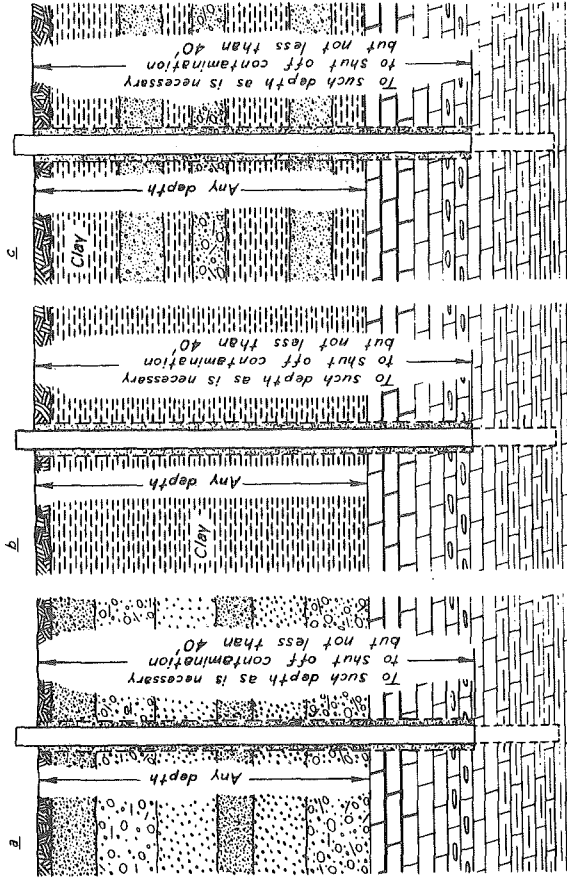

Figure A-12. Construction of Wells Terminating in Limestone Underlying Unconsolidated Materials comprising mainly Sand and Gravel, or Clay or Similar Material or a Mixture of Sand, Gravel and Clay or Similar Material, extending to variable depths, by either Percussion or Rotary Equipment. See Table 1, d, e and f.

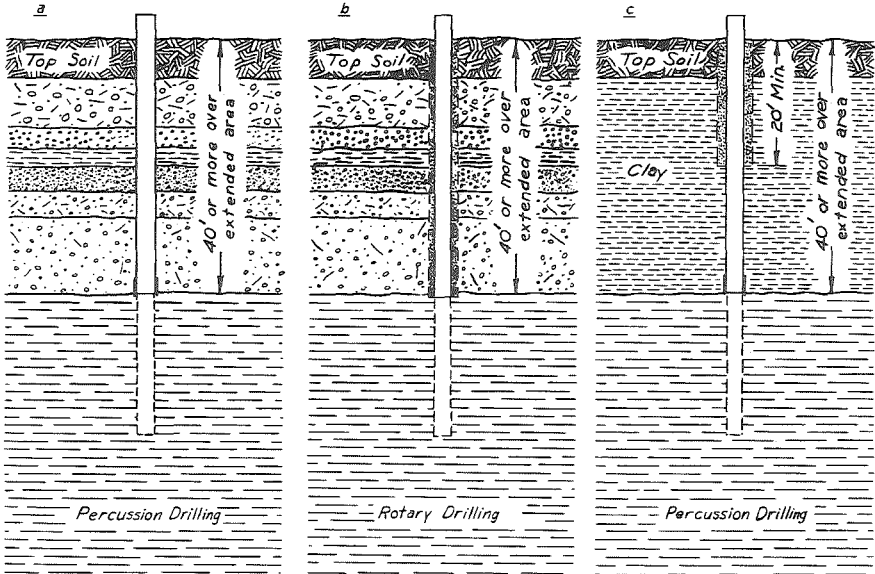

Figure A-13. Construction of Wells Terminating in Shale Underlying Unconsolidated Materials comprising mainly Sand and Gravel or Clay or Similar Material, extending to a depth of 40 feet or greater depth. See Table I, g and h.

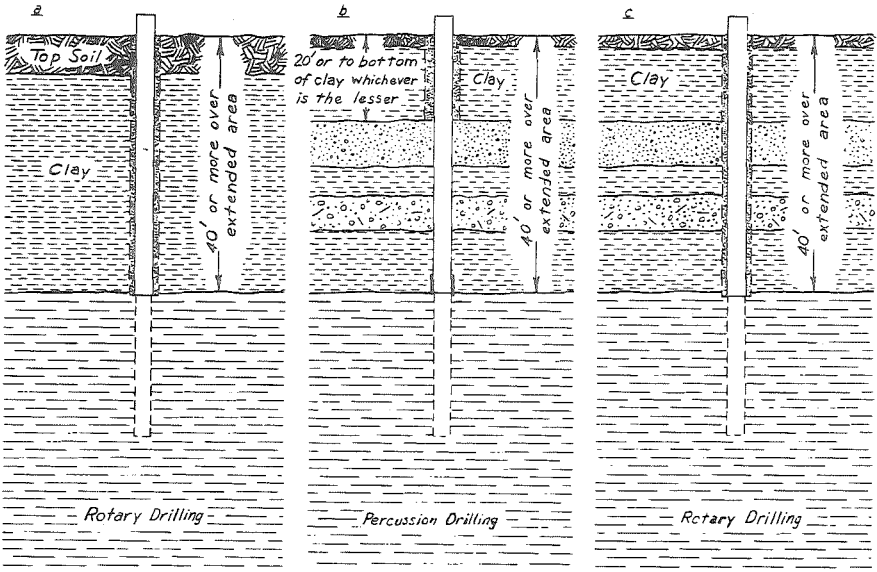

Figure A-14. Construction of Wells Terminating in Shale Underlying Clay or Similar Material or such materials with some Sand and Gravel Zones, extending to a depth of 40 feet or greater depth. See Table I, h.

NR 112

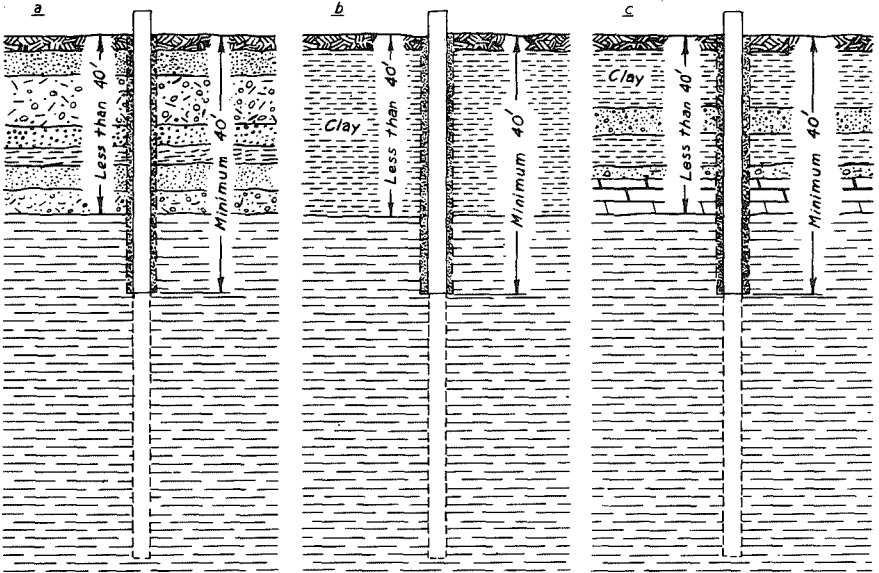

Figure A-15. Construction of Wells Terminating in Shale Underlying Unconsolidated Materials comprising mainly Sand and Gravel, or Clay or Similar Material, or a Mixture of Sand, Gravel and Clay or Similar Material, extending to a depth of less than 40 feet, by either Percussion or Rotary Equipment. See Table 1, i.

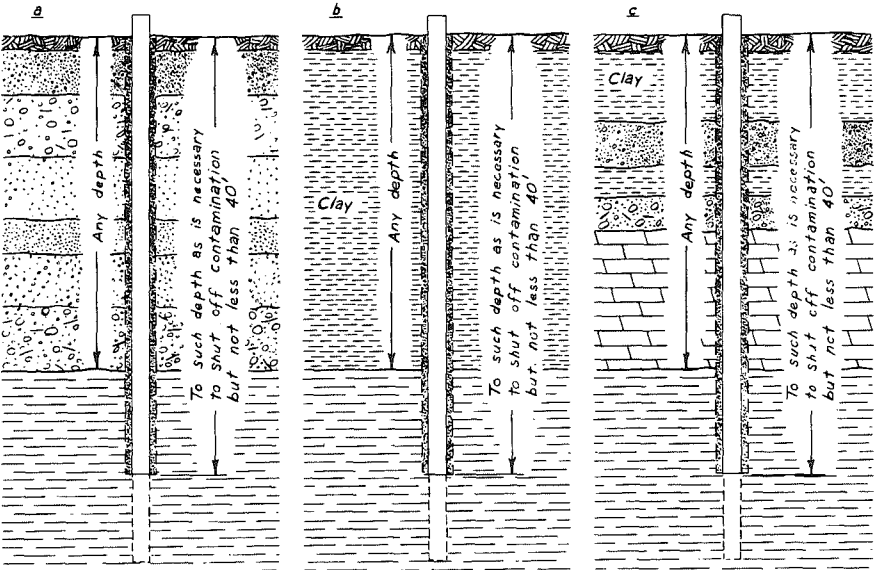

Figure A-16. Construction of Wells Terminating in Shale Underlying Unconsolidated Materials comprising mainly Sand and Gravel, or Clay or Similar Material, or a Mixture of Sand, Gravel and Clay or Similar Material, extending to variable depths, by either Percussion or Rotary Equipment. See Table 1, g, h and i.

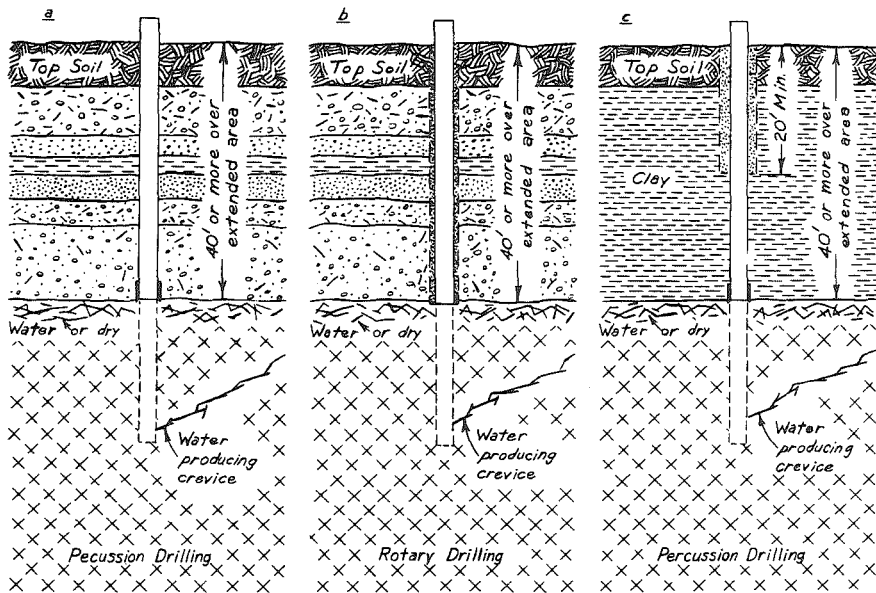

Figure A-17. Construction of Wells Terminating in Granite or Quartzite Underlying Unconsolidated Materials, comprising mainly Sand and Gravel or Clay or Similar Material, extending to a depth of 40 feet or greater depth. See Table 1, j and k.

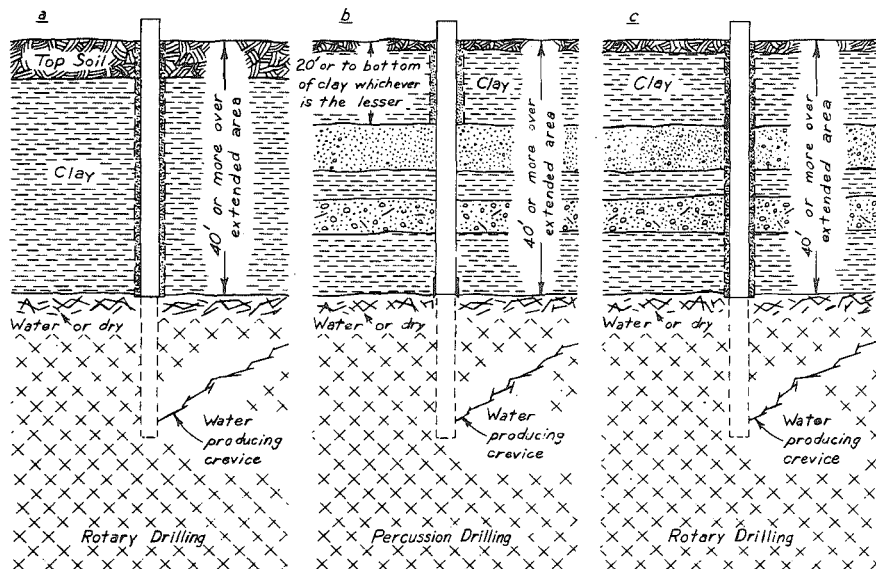

Figure A-18. Construction of Wells Terminating in Granite or Quartzite Underlying Clay or Similar Material or such Materials with some Sand and Gravel Zones, extending to a depth of 40 feet or greater depth. See Table 1, k.

NR 112

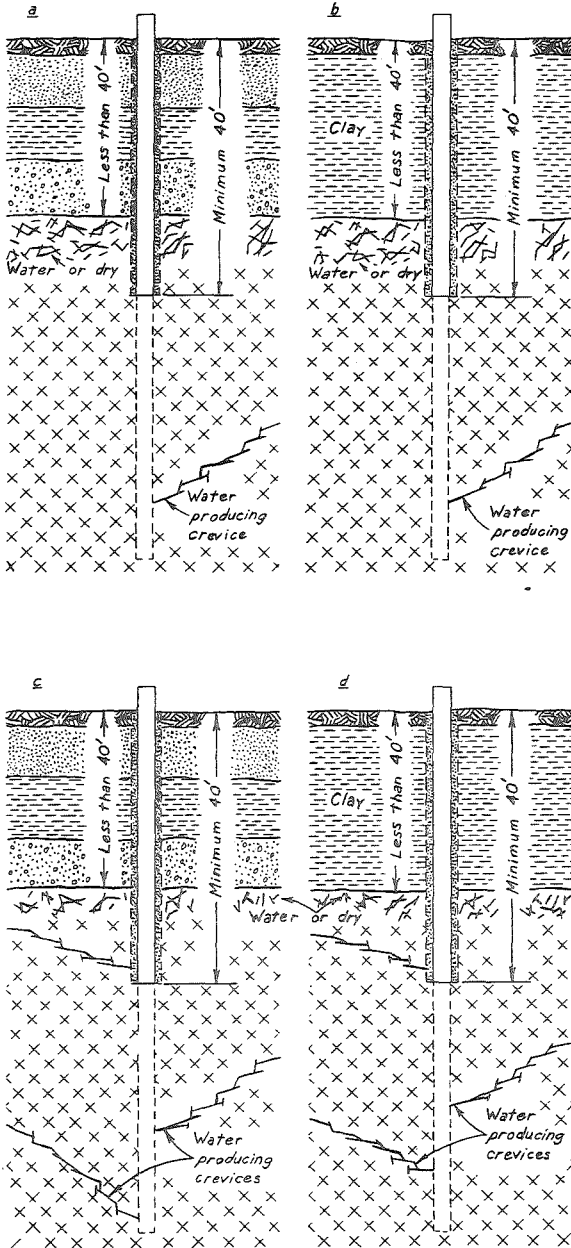

Figure A-19. Construction of Wells Terminating in Granite or Quartzite Underlying Unconsolidated Materials, extending to a depth of less than 40 feet, by either Percussion or Rotary Equipment. See Table 1, l.

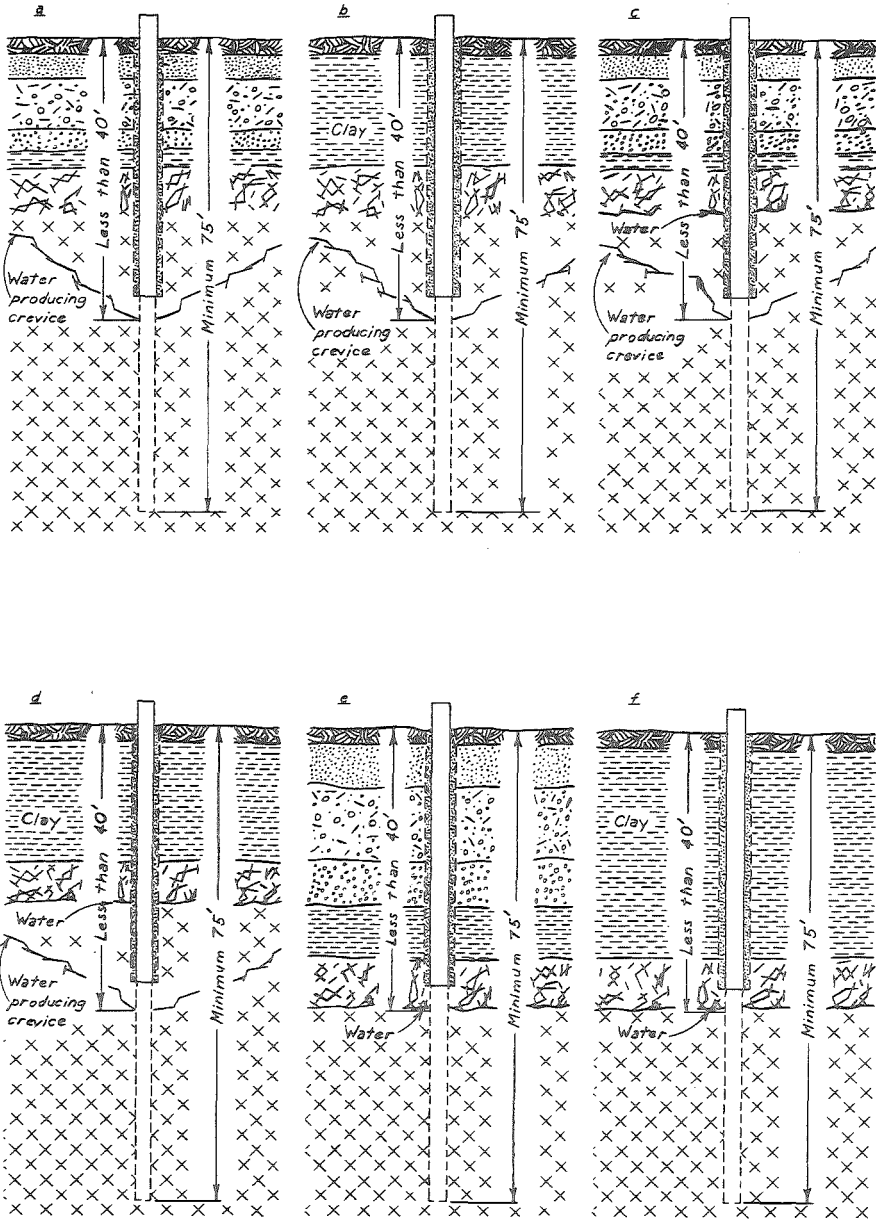

Figure A-20. Construction of Wells Terminating in Granite or Quartzite Underlying Unconsolidated Materials comprising mainly Sand and Gravel, or Clay or Similar Material or a Mixture of Sand, Gravel and Clay or Similar Material, extending to a depth of less than 40 feet, by either Percussion or Rotary Equipment. Permission is required to construct a well with less than 40 feet of well casing pipe. See Table 1, l.

NR 112

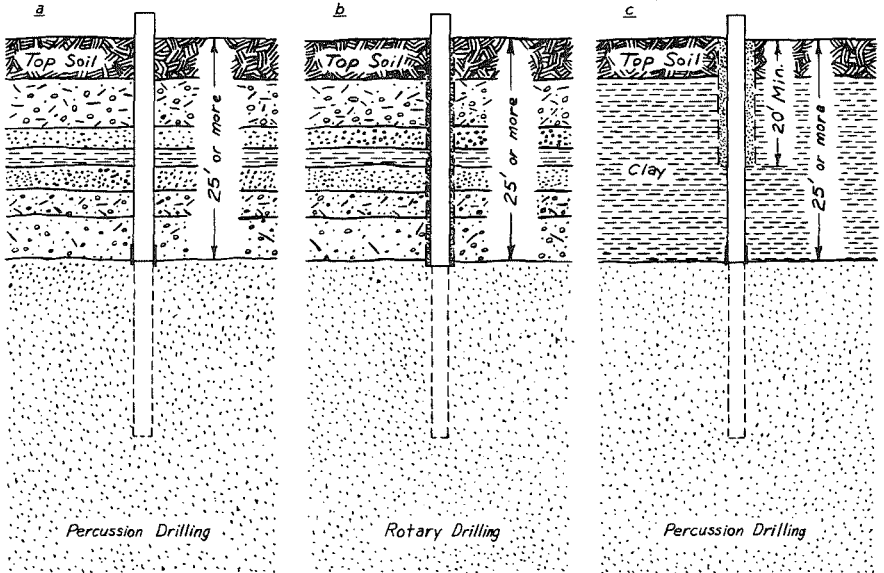

Figure A-21. Construction of Wells Terminating in Sandstone Underlying Unconsolidated Materials comprising mainly Sand and Gravel, or Clay or Similar Material, extending to a depth of 25 feet or greater depth. See Table 1, m and n.

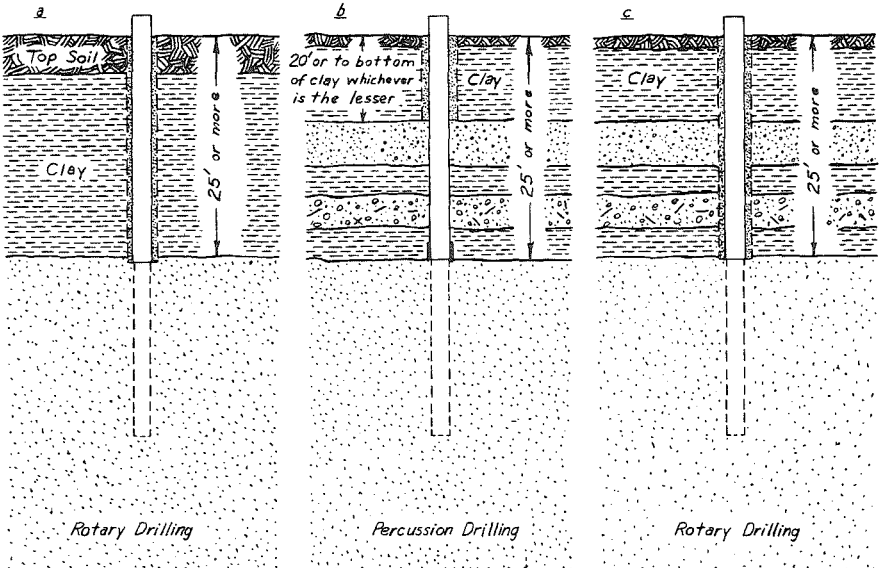

Figure A-22. Construction of Wells Terminating in Sandstone Underlying Clay or Similar Material or such Materials with some Sand and Gravel, extending to a depth of 25 feet or greater depth. See Table 1, n.

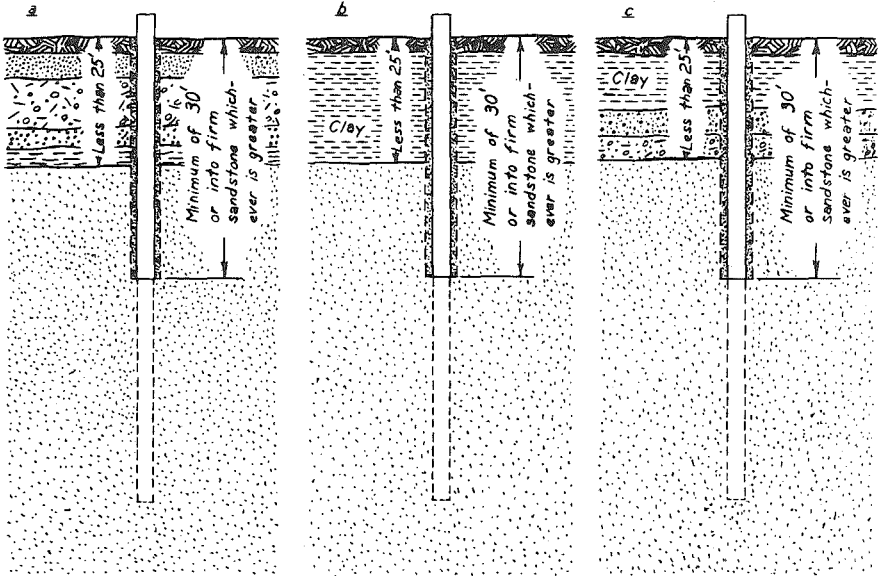

Figure A-23. Construction of Wells Terminating in Sandstone Underlying any Material except Limestone, extending to a depth of less than 25 feet, by either Percussion or Rotary Equipment. See Table 1, o.

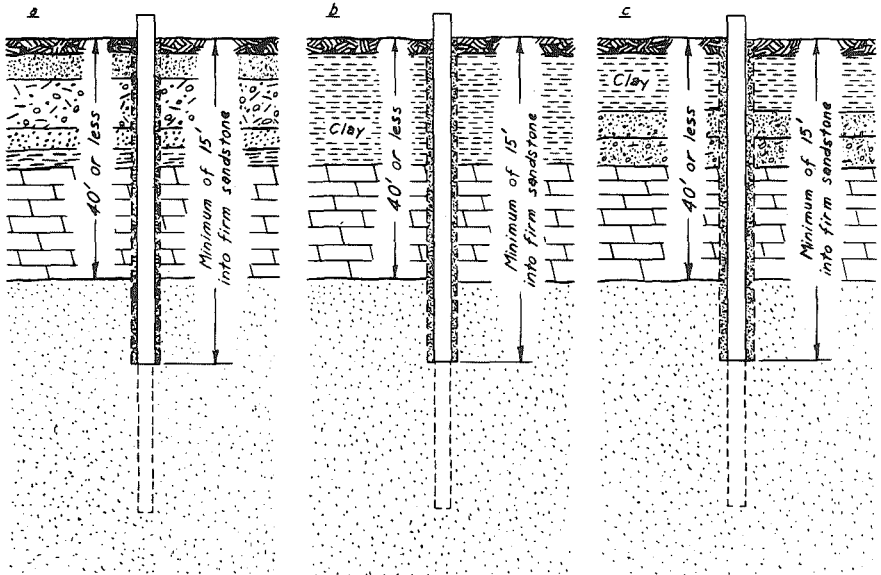

Figure A-24. Construction of Wells Terminating in Sandstone Underlying Limestone extending to a depth of 40 feet or less with or without Unconsolidated Overburden over the Limestone, by either Percussion or Rotary Equipment. See Table 1, p.

NR 112

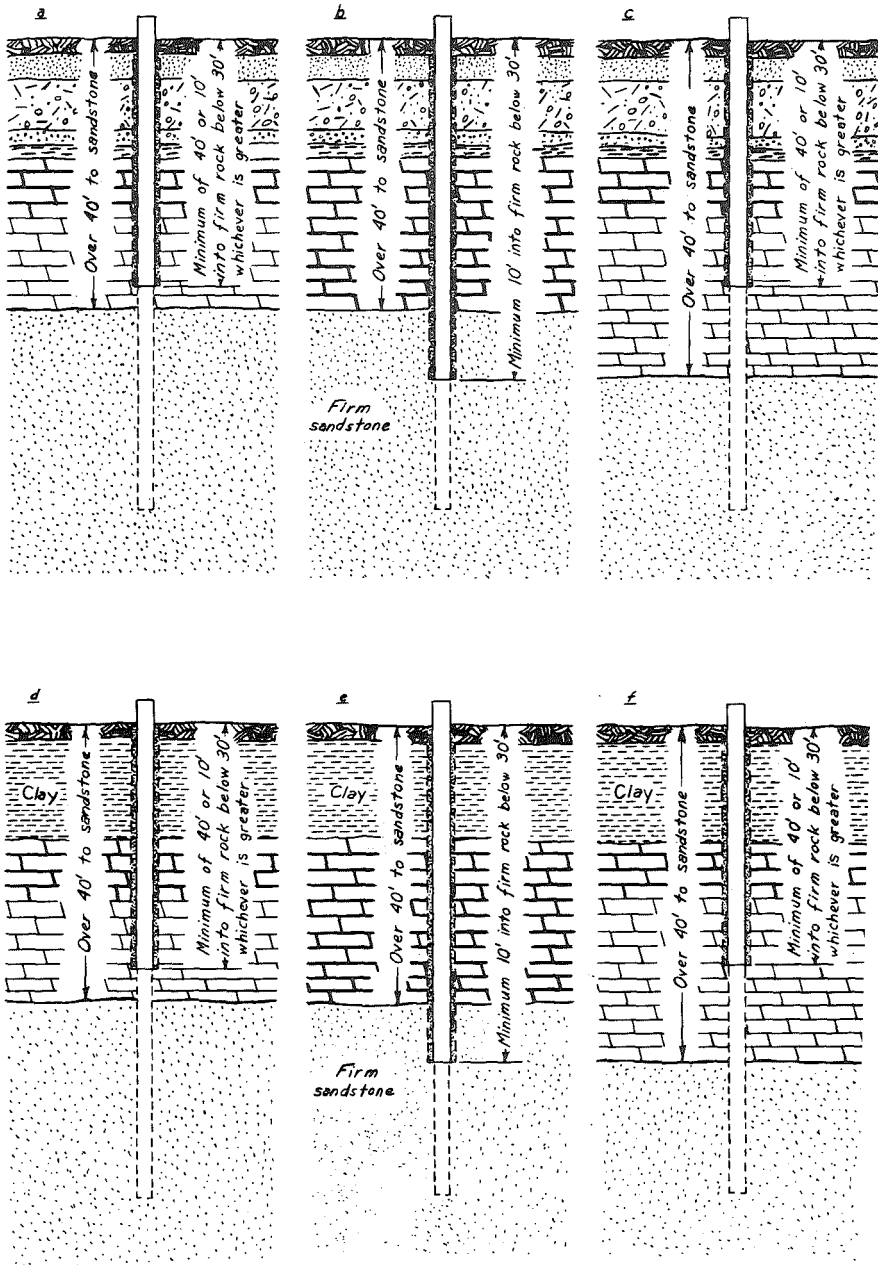

Figure A-25. Construction of Wells Terminating in Sandstone Underlying Limestone extending to a depth greater than 40 feet with or without Unconsolidated Overburden over the Limestone, by either Percussion or Rotary Equipment. See Table 1, q.