

Chapter Trans 308

**REQUIREMENTS FOR TRAILER AND SEMI-TRAILER
 BRAKE, HITCH AND COUPLING, SAFETY
 CHAINS, CABLES AND LEVELING BARS**

Trans 308.01	Emergency braking		
Trans 308.02	Brake tubing and hose, adequacy	Trans 308.11	minimum strength requirements of hitch and coupling
Trans 308.03	Brake tubing and hose connections		Minimum strength ratings, coupling and ball, trailers and mobile homes
Trans 308.04	Brake lining	Trans 308.12	Safety chains or cables for trailers and mobile homes
Trans 308.05	Brakes to be operative	Trans 308.13	Leveling bars
Trans 308.06	Single valve to operate all brakes	Trans 308.14	Safety chain or cable for full trailer converter dollies connected by means of a pintle and tow bar eye
Trans 308.07	Warning devices and gauges		
Trans 308.08	Electrical brake connections		
Trans 308.09	Brake performance		
Trans 308.10	Trailer and mobile home classification and standard		

Trans 308.01 Emergency braking. (1) Every truck or truck tractor equipped with air brakes, when used for towing other vehicles equipped with air brakes, shall be equipped with 2 means of activating the emergency features of the trailer brakes. One of these means shall operate automatically in the event of reduction of the towing vehicle air supply to a fixed pressure which shall not be lower than 20 pounds per square inch nor higher than 45 pounds per square inch. The other means shall be a manually controlled device readily operable by a person seated in the driving seat. Its emergency position or method of operation shall be clearly indicated. In no instance may the manual means be so arranged as to permit its use to prevent operation of the automatic means. The automatic and manual means required by this section may be, but are not required to be separate.

(2) Every truck tractor and truck when used for towing other vehicles equipped with vacuum brakes, shall have, in addition to the single control required by section Trans 308.06 to operate all brakes of the combination, a second manual control device which can be used to operate the brakes on the towed vehicles in emergencies. Such second control shall be independent of other controls, unless the braking system be so arranged that failure of the pressure on which the second control depends will cause the towed vehicle brakes to be applied automatically. The second control is not required by this rule to provide modulated or graduated braking.

(3) Air brake systems installed on towed vehicles shall be so designed, by the use of "no-bleed-back" relay emergency valves or equivalent devices, that the supply reservoir used to provide air for brakes shall be safeguarded against backflow of air to the towing vehicle upon reduction of the towing vehicle air pressure.

(4) The requirements of subs. (2) and (3) shall not be applicable to motor vehicles in driveaway-towaway operations.

History: Cr. Register, July, 1968, No. 151, eff. 8-1-68; renun. from MVD 8.01 and am. (2), Register, September, 1980, No. 297, eff. 10-1-80.

Trans 308

Trans 308.02 Brake tubing and hose, adequacy. Brake tubing and brake hose shall be:

(1) Designed and constructed of proper material and so installed and maintained as to insure proper continued functioning;

(2) Sufficiently long and flexible as to accommodate without damage all normal motions of the parts to which they are attached;

(3) Suitably secured against chafing, kinking, or other mechanical injury; and

(4) (a) Brake hose shall be so constructed as to insure adequate and reliable functioning and shall conform to the appropriate specification set forth in the SAE Standards for "Hydraulic Brake Hose Assemblies for use with Non-Petroleum Base Hydraulic Fluids," SAE J1401a; "Automotive Air Brake Hose and Hose Assemblies," J1402c; or "Vacuum Brake Hose," J1403a. (See 1980 SAE Handbook.)

(b) The above referred to SAE Standards are on file in the offices of the Department of Transportation, the Secretary of State and the Revisor of Statutes, and may be obtained from the Society of Automotive Engineers, Inc., 400 Commonwealth Drive, Warrendale, Pennsylvania 15096.

History: Cr. Register, July, 1968, No. 151, eff. 8-1-68; renum. from MVD 8.02 and am. (4), Register, September, 1980, No. 297, eff. 10-1-80.

Trans 308.03 Brake tubing and hose connections. All connections for air, vacuum, or hydraulic braking systems shall:

(1) Be adequate in material and construction to insure proper continued functioning;

(2) Be designed, constructed, installed and maintained so as to insure, when properly connected, an attachment free of leaks, constrictions, or other defects;

(3) Have suitable provision in every detachable connection to afford reasonable assurance against accidental disconnection;

(4) Have the vacuum brake engine manifold connection at least three-eighths inch in diameter.

History: Cr. Register, July, 1968, No. 151, eff. 8-1-68; renum. from MVD 8.03, Register, September, 1980, No. 297, eff. 10-1-80.

Trans 308.04 Brake lining. The brake lining on every trailer type vehicle shall be so constructed, installed and maintained as not to be subject to excessive fading and grabbing and shall be adequate in thickness, means of attachment, and physical characteristics to provide for safe and reliable stopping of the vehicle.

History: Cr. Register, July, 1968, No. 151, eff. 8-1-68; renum. from MVD 8.04, Register, September, 1980, No. 297, eff. 10-1-80.

Trans 308.05 Brakes to be operative. All brakes with which trailer-type vehicles are equipped shall be operative at all times except brakes need not be operative on disabled vehicles being towed.

History: Cr. Register, July, 1968, No. 151, eff. 8-1-68; renum. from MVD 8.05, Register, September, 1980, No. 297, eff. 10-1-80.

Register, September, 1980, No. 297

Trans 308.06 Single valve to operate all brakes. Every motor vehicle, the date of manufacture of which is subsequent to June 30, 1953, which is equipped with power brakes, shall have the braking system so arranged that one application valve shall when applied operate all the service brakes on the motor vehicle or combination of motor vehicles. This requirement shall not be construed to prohibit motor vehicles from being equipped with an additional valve to be used to operate the brakes of a trailer or trailers. This section shall not be applicable to driveaway-towaway operations unless the brakes on such operations are designed to be operated by a single valve.

History: Cr. Register, July, 1968, No. 151, eff. 8-1-68; renum. from MVD 8.06, Register, September, 1980, No. 297, eff. 10-1-80.

Trans 308.07 Warning devices and gauges. (1) **AIR BRAKES AS PROVIDED IN SUB. (4).** Every truck and truck tractor using compressed air for the operation of its own brakes or the brakes of any towed vehicle shall be equipped with a warning signal readily audible or visible to the driver, which will give continuous warning at all pressures below a fixed pressure not less than one-half of the compressor governor cut-out pressure. In addition, each such vehicle shall be equipped with a pressure gauge which will indicate to the driver the pressure in pounds per square inch available for braking.

(2) **VACUUM BRAKES AS PROVIDED IN SUB. (4).** Every truck and truck tractor using vacuum for the operation of its own brakes and vacuum for the brakes on any towed vehicle shall be equipped with a warning signal readily audible or visible to the driver, which will give continuous warning at any time the vacuum in the vehicle's supply reservoir is less than 8 inches of mercury. In addition, each such vehicle shall be equipped with a vacuum gauge which will indicate to the driver the vacuum in inches of mercury available for braking.

(3) **MAINTENANCE.** The warning devices and gauges required by this section shall be maintained in operative condition.

(4) **APPLICATION.** This section applies to all combinations of property-carrying vehicles utilizing trailers or semi-trailers where the gross weight of the trailer or semi-trailer is 3000 pounds or more.

History: Cr. Register, July, 1968, No. 151, eff. 8-1-68; renum. from MVD 8.07, Register, September, 1980, No. 297, eff. 10-1-80.

Trans 308.08 Electrical brake connections. All electrical wiring shall be mechanically and electrically adequate and free of short or open circuits. Suitable provision shall be made in every such detachable connection to afford reasonable assurance against connection in an incorrect manner or accidental disconnection. Detachable connections made by twisting together wires from the towed and towing units are prohibited. Precaution shall be taken to provide sufficient slack in the connecting wire or cable to accommodate without damage all normal motions of the parts to which they are attached.

History: Cr. Register, July, 1968, No. 151, eff. 8-1-68; renum. from MVD 8.08, Register, September, 1980, No. 297, eff. 10-1-80.

Trans 308.09 Brake performance. Every combination of vehicles, at all times and under all conditions of loading, upon application of the

Trans 308

service brake, shall be capable of stopping from a speed of 20 miles per hour in not more than 50 feet.

History: Cr. Register, July, 1968, No. 151, eff. 8-1-68; renum. from MVD 8.09, Register, September, 1980, No. 297, eff. 10-1-80.

Trans 308.10 Trailer and mobile home classification and standard minimum strength requirements of hitch and coupling. (1)

HITCH DEFINITION. The hitch is that part of the connecting mechanism, including the coupling platform and its attaching members or weldments, which is attached to the towing vehicle.

(2) **COUPLING DEFINITION.** The coupling is that part of the connecting mechanism, including the coupling and its attaching members or weldments, which is attached to the trailer or mobile home and by which connection is made to the hitch.

(3) **TRAILER AND MOBILE HOME CLASSIFICATION.** Trailers and mobile homes shall be classified according to the following gross weights, which gross weight shall include the weight of the vehicle and the actual load carried.

(a) Class 1—All vehicles whose gross weight does not exceed 2000 lbs.

(b) Class 2—All vehicles in excess of 2000 lbs. gross weight but not exceeding 3500 lbs. gross weight.

(c) Class 3—All vehicles in excess of 3500 lbs. gross weight and not exceeding 5000 lbs. gross weight.

(d) Class 4—All vehicles with gross weight, in excess of 5000 lbs. but not to exceed 10,000 lbs.

(e) Class 5—All vehicles with a gross weight in excess of 10,000 lbs.

(4) **STRENGTH RATING FOR TRAILER AND MOBILE HOME COUPLINGS AND FOR CLASS 5 VEHICLE HITCHES.** (a) The trailer or mobile home coupling shall be of such design as to conform to the minimum strength requirements set forth in par. (b) of this section. Where a ball-and-socket type of coupling is used, the ball must conform to the minimum load ratings of the mating coupling.

(b) Minimum strength ratings for the coupling used in conjunction with specific classes of trailers and mobile homes and for the hitch used in conjunction with Class 5 vehicles.

Vehicle Classification	Minimum Breaking Point Requirements of Coupling and of Class 5 Vehicle Hitch
Class 1	Longitudinal tension..... 6,000 lbs. Longitudinal compression..... 6,000 lbs. Transverse thrust..... 2,000 lbs. Vertical tension..... 2,500 lbs. Vertical compression..... 2,500 lbs.
Class 2	Longitudinal tension..... 10,500 lbs. Longitudinal compression..... 10,500 lbs. Transverse thrust..... 3,000 lbs. Vertical tension..... 4,500 lbs. Vertical compression..... 4,500 lbs.
Class 3	Longitudinal tension..... 15,000 lbs. Longitudinal compression..... 15,000 lbs. Transverse thrust..... 4,000 lbs. Vertical tension..... 7,000 lbs. Vertical compression..... 7,000 lbs.
Class 4	Longitudinal tension-gross weight of trailer-type vehicle in pounds x 3. Longitudinal compression-gross weight of trailer-type vehicle in pounds x 3. Transverse thrust-gross weight of trailer-type vehicle in pounds x 1. Vertical tension-gross weight of trailer-type vehicle in pounds x 1.3. Vertical compression-gross weight of trailer-type vehicle in pounds x 1.3.
Class 5	Strength rating of hitch and coupling for trailers over 10,000 lbs.—Each coupling system, other than safety chain or cable, shall have a minimum longitudinal strength, in both tension and compression, no less than 130% of the gross weight towed by the coupling system. The coupling system shall include not only coupling devices such as tow bars, pintles, and tow bar eyes, but also all the members, means and attachments used to fasten or to secure the coupling device to the motor vehicle.

(5) **COUPLING, MOUNTING.** Each coupling is to be mounted to the attaching member by bolting, welding or riveting in such manner that the maximum loading required for the coupling designation shown in (4) (b) is safely and adequately transferred to that member.

(6) **REQUIRED MECHANISM.** Each hitch and coupling, regardless of classification, must be equipped with a manually operated mechanism so adapted as to prevent disengagement of the unit while in operation.

(7) **STRENGTH RATING FOR TRAILER AND MOBILE HOME HITCHES.** (a) The hitch and its coupling platform shall be of such design and shall be so

Trans 308

attached to the towing vehicle as to safely and adequately handle the gross load of trailer or mobile home including contents thereof.

History: Cr. Register, July, 1968, No. 151, eff. 8-1-68; renum. from MVD 8.10 and am. (3) (a) to (d) and (4) (b), cr. (3) (e), r. (4) (c), Register, September, 1980, No. 297, eff. 10-1-80.

Trans 308.11 Minimum strength ratings, couplng and ball, trailers and mobile homes. Minimum strength ratings for the couplng and ball for trailers and mobile homes are as follows:

Maximum Gross Wt.	Minimum Ball Diam.	Minimum Ball Bolt Diam.
2000 lbs	1-7/8"	5/8"
3500 lbs	2"	11/18"
5000 lbs	2"	3/4"
over 5000 lbs	Ball and bolt sizes shall equal or exceed the larger of the above classification. In addition the ball and bolts shall be of sufficient size and strength to prevent collapse or shearing under the actual gross towed weight.	

History: Cr. Register, July, 1968, No. 151, eff. 8-1-68; renum. from MVD 8.11, Register, September, 1980, No. 297, eff. 10-1-80.

Trans 308.12 Safety chains or cables for trailer and mobile homes. (1) **NUMBER OF LENGTHS OF CHAIN REQUIRED.** Two separate lengths of safety chain or cable shall be required on all trailers and mobile homes. This requirement shall not apply to semitrailers having a connecting device composed of a fifth wheel and kingpin assembly (s. 347.47 (3), Stats.), to a pole or pipe dolly (s. 347.47 (3), Stats.), nor between towing vehicles and full trailers or trailer converter dollies when the towing vehicle is connected to the towed vehicle by means of a pintle and tow bar eye and all the installation and capacity requirements of s. Trans 308.14, Wis. Adm. Code, are met.

(2) **STRENGTH RATINGS FOR SAFETY CHAINS OR CABLES.** The strength rating for each length of safety chain or cable used in conjunction with trailers and mobile homes shall be as follows:

Maximum Gross Wt.	Minimum Chain Size	Minimum Cable Size
2000 lbs	3/16" proof coil steel chain or equivalent	5/32" diam. 7 x 19 preformed aircraft cable or equivalent
3500 lbs	1/4" proof coil steel welded chain or equivalent	3/16" diam. 7 x 19 preformed aircraft cable or equivalent
5000 lbs	5/16" proof coil steel welded chain or equivalent	7/32" diam. 7 x 19 preformed aircraft cable or equivalent
over 5000 lbs	Strength rating of each length of safety chain or cable shall be equal in minimum break test load to the gross weight of the trailer or mobile home.	

(3) **ATTACHMENT OF SAFETY CHAINS.** The means of attachment of safety chains shall be located equally distant from and on opposite sides of the longitudinal centerline of the towing vehicle and the trailer. Each means of attachment shall have no towing function other than the connection of safety chains and shall not be common with or utilize fasteners com-

mon with a ball, socket, ring, pintle, clevis, pin or other equivalent portion of the primary towing arrangement. No welding operation shall be performed on safety chain subsequent to its manufacture. Safety chains shall be so connected that the slack for each length of chain between the trailer and towing vehicle is the same and is not more than necessary to permit proper turning of the vehicles. Each means of attaching chain or cable shall have a longitudinal strength at least equal to the total gross towed weight.

(4) **TILT BED TRAILERS, EQUIPMENT.** All tilt bed trailers built with a swivel pole to permit angling of pole for forward drive unloading, shall be equipped with a chain at that point where the bend is joined to the pole. Chain shall be of sufficient strength, adequately fastened, and short enough to prohibit the trailer from angling in the event the connecting pin breaks or becomes disconnected.

History: Cr. Register, July, 1968, No. 151, eff. 8-1-68; renum. from MVD 8.12, and am. (1) and (2) (intro.), Register, September, 1980, No. 297, eff. 10-1-80.

Trans 308.13 Leveling bars. The strength rating of each leveling bar, or part of such unit, shall be not less than:

(1) Longitudinal tension—gross load of trailer-type vehicle in pounds x 3

(2) Longitudinal compression—gross load of trailer-type vehicle in pounds x 3

(3) Transverse thrust—gross load of trailer-type vehicle in pounds x 1

(4) Vertical tension—gross load of trailer-type vehicle in pounds x 1.3

(5) Vertical compression—gross load of trailer-type vehicle in pounds x 1.3

History: Cr. Register, July, 1968, No. 151, eff. 8-1-68; renum. from MVD 8.13, Register, September, 1980, No. 297, eff. 10-1-80.

Trans 308.14 Safety chain or cable for full trailers or trailer converter dollies connected by means of a pintle and tow bar eye. (1) **DEFINITIONS.** (a) Full trailer means a truck trailer whose weight is carried entirely on its own wheels.

(b) Trailer converter dolly means a truck trailer with one or more axles equipped with a fifth wheel, a drawbar and other parts necessary to convert a semitrailer to a full trailer.

(c) Truck trailer means a vehicle without auxiliary motive power designed to be drawn by a motor truck or truck tractor, but does not include a mobile home.

(d) Safety chain means the chain or cable from the front of a full trailer or a trailer converter dolly to the rear of the towing vehicle for the purpose of retaining the connection between the towing and the towed vehicles and of controlling the direction of travel of the towed vehicle in the event of failure of the drawbar or the connection on the rear of the towing vehicle.

(e) Pintle means a connection meeting the requirements of SAE J849b. See Fig. 1 following this section.

(f) Tow bar eye means a device attached to the tow bar of the full trailer or trailer converter dolly meeting the requirements of SAE J847. See Fig. 2 following this section.

(2) USE OF A SINGLE LENGTH OF SAFETY CHAIN OR CABLE. A single length of chain or of cable or a bridle arrangement of a single chain or cable may be used between a towing vehicle and a full trailer or between a towing vehicle and a trailer converter dolly when the towing vehicle is connected to the towed vehicle by means of a pintle and tow bar eye if all the installation and capacity requirements of this section are met.

(3) INSTALLATION. (a) The safety chain shall be attached by suitable means to the frame of the full trailer or of the trailer converter dolly to which full trailer or trailer converter dolly a hinged drawbar is attached and to the frame of the towing vehicle. Trailer converter dollies with solid tongues and without hinged tow bars may have the safety chain attached to the solid tongue. The connection or coupling device shall not be used as a means of attaching the safety chain to the towing vehicle frame. The safety chain shall be attached to both the towing and the towed vehicles in such a manner so as to be capable of developing the full capacity of the chain into the frame members of the towing and towed vehicles. The safety chain shall be so installed as to support the drawbar and prevent it from dropping to the ground in the event of failure of the drawbar or connection on the rear of the towing vehicle. The safety chain shall be attached and installed so as to keep the trailer in a straight line back of the towing vehicle insofar as practicable in the event of failure of the drawbar, connection or coupling device. The safety chain shall have no more slack, when in use, than is necessary to permit proper turning of the vehicle.

(b) Two safety chains or 2 cables, when used, may be attached to the full trailer front axle or to the trailer converter dolly axle near the wheels in lieu of the requirements set forth in par. (a) of this subsection. The means of attachment shall be capable of developing the full capacity of the safety chains or cables into the axle and shall meet all the requirements set forth in s. Trans 308.12 (3), Wis. Adm. Code.

(4) CAPACITY. (a) The safety chain capacity shall be equal to the gross weight of the vehicle or vehicles being towed. For the purpose of this section, the safety chain capacity shall be the published breaking strength. The safety cable capacity shall be the published breaking strength. In the absence of a published breaking strength, the safety chain or cable capacity shall be the ultimate strength by actual test performed by the manufacturer.

(b) When 2 chains or 2 cables are used, each chain or cable shall have a capacity equal to the gross vehicle weight of the vehicle or vehicles being towed.

(c) Breaking strengths are given as follows:

Type	Published Breaking Strength, lb.
Alloy Steel Chain, in.	
1/2	32,500
5/8	50,000
3/4	69,500
Wire Rope Fed Spec RR-W-410a Type 1, Class 2	
6 x 19 Plow Steel with Steel Core, in.	
1/2	23,000
9/16	29,000
5/8	36,000
3/4	51,200
7/8	69,200
Roebing Royal Blue Wire Rope 6 x 19, in.	
1/2	26,600
9/16	33,600
5/8	41,200
3/4	59,800
7/8	79,600

(5) The following figures are Society of Automotive Engineers' (SAE) recommended practices found in the 1980 SAE Handbook. These recommended practices are on file in the offices of the Department of Transportation, the Secretary of State and the Revisor of Statutes, or may be obtained from the Society of Automotive Engineers, Inc., 400 Commonwealth Drive, Warrendale, Pennsylvania 15096.

History: Cr. Register, September, 1980, No. 279, eff. 10-1-80.

CONNECTION AND ACCESSORY LOCATIONS FOR TOWING DOUBLES TRAILERS AND MULTI-AXLE TRAILERS—SAE J849b

SAE Recommended Practice

Report of Transportation and Maintenance and Truck and Bus Technical Committees approved June 1963 and last revised January 1970.

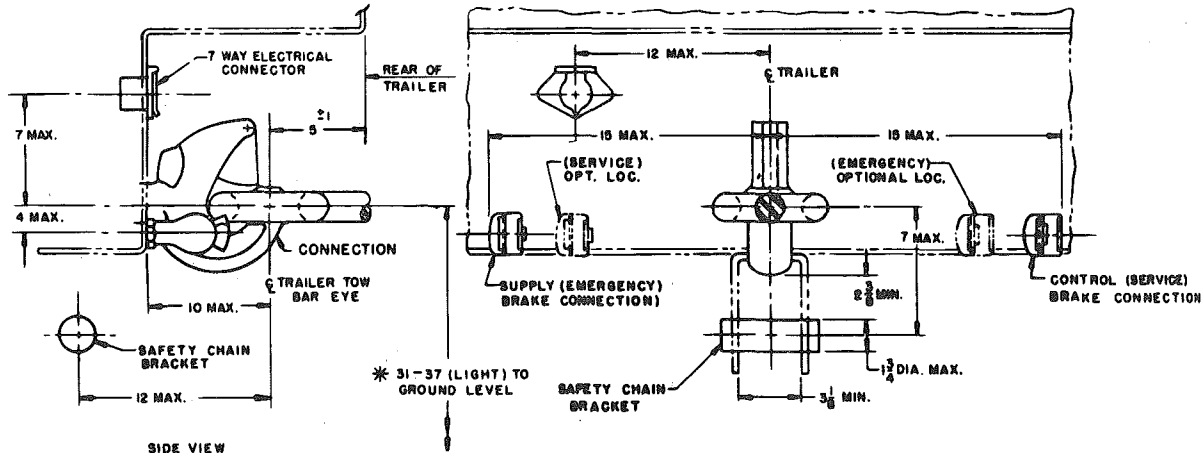

SIDE VIEW

* FOR TRUCK INSTALLATION, THIS DIMENSION TO BE 27-33.

This SAE Recommended Practice applies to all commercial trailers exceeding 40,000 lb gvwt, except drop frame types.

Connection and mounting structure must withstand a tow bar pull equivalent to 115% of the gvwt of the towed trailer without residual deformation to mounting or trailer structure.

NOTE: All dimensions given in inches.

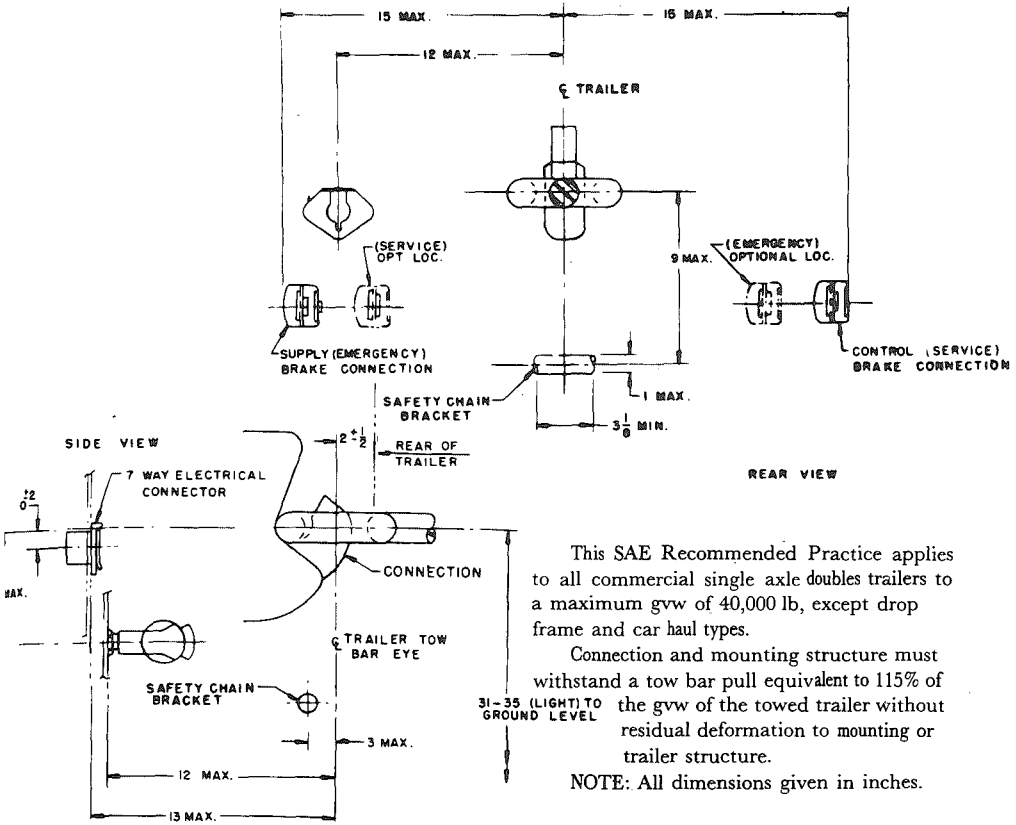

This SAE Recommended Practice applies to all commercial single axle doubles trailers to a maximum gw of 40,000 lb, except drop frame and car haul types.

Connection and mounting structure must withstand a tow bar pull equivalent to 115% of the gw of the towed trailer without residual deformation to mounting or trailer structure.

NOTE: All dimensions given in inches.

Clearance space shown must extend 7 in. above and 7 in. below the horizontal centerline of the drawbar eye as shown in Section A-A.

NOTE: All dimensions given in inches.

37.20

FULL TRAILER TOW BAR EYE—SAE J847

SAE Recommended Practice

Report of Transportation and Maintenance and Truck and Bus Technical Committees approved June 1963.

This SAE Recommended Practice for commercial trailer tow bar eye applies to trailer converter and full trailer.

NOTE: Trailer tow bar eye, and its attachment to towing vehicle, must withstand a 60,000 lb tow bar pull without residual deformation.

