

Chapter MVD 22

STANDARDS AND SPECIFICATIONS—DESIGN AND MOUNTING SMV EMBLEM

MVD 22.01 Purpose and scope	MVD 22.04 Test procedures
MVD 22.02 Emblem description	MVD 22.05 Mounting
MVD 22.03 Performance requirements	

**MVD 22.01 Purpose and scope.** The purpose of this standard is to establish specifications which define an identification emblem for use on slow-moving vehicles when operated on the highway. This standard establishes emblem dimensional specifications, performance requirements, and related test procedures.

**History:** Cr. Register, December, 1969, No. 168, eff. 1-1-70.

**MVD 22.02 Emblem description.** The identification emblem (Fig. 1) shall consist of a fluorescent yellow-orange triangle with a dark, red reflective border. The yellow-orange fluorescent triangle is for daylight identification. The reflective border defines the shape of the fluorescent color in daylight and becomes a hollow red triangle in the path of motor vehicle headlights at night.

**History:** Cr. Register, December, 1969, No. 168, eff. 1-1-70.

**MVD 22.03 Performance requirements.** (1) **VISIBILITY.** The emblem shall be entirely visible in daylight and at night from all distances between 600 ft. and 100 ft. from the rear when directly in front of lawful upper beam of headlamps.

(2) **DIMENSIONAL REQUIREMENTS.** The size shall be as shown in Fig. 1.

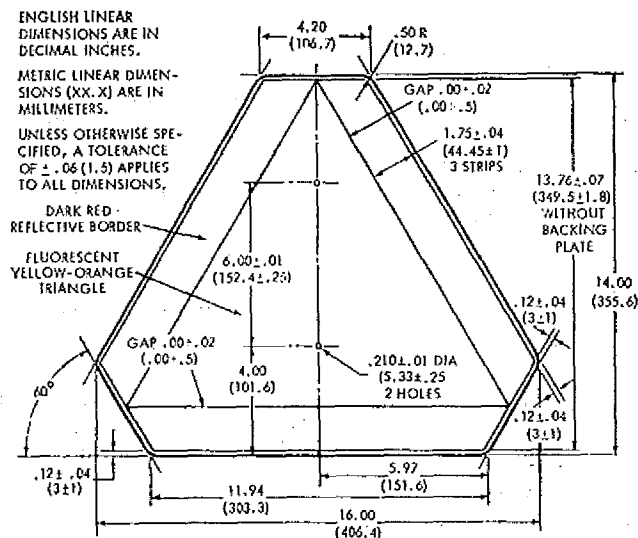

Fig. 1—Identification Emblem

Register, June, 1982, No. 318

(3) **COLOR AND REFLECTIVITY.** The spectrophotometric color values of the yellow-orange fluorescent material shall have a dominant wave length of 590-610 millimicrons and a purity of 98% before test. After durability test, the dominant wave length of the fluorescent material shall not change more than 10%.

(4) **REFLECTIVE INTENSITY VALUES.** The reflective material shall have minimum intensity values at each of the angles listed per table 1. After durability test, the minimum reflective intensity values for the reflective material shall not change more than 20% from the values specified in table 1.

TABLE 1

Minimum Reflective Intensity Values, R\*

Divergence Angle, deg	Incidence Angle, deg	Reflective Intensity, R
0.2	0	10
0.2	15	7
0.2	30	5
0.5	0	5
0.5	15	4
0.5	30	2

\*Measurements shall be conducted in accordance with photometric testing procedures for reflex-reflectors as specified in Society of Automotive Engineers Standard, SAE J594d, Reflex Reflectors, and using 50. - 5 sq. in. (322.6 - 32.3 sq. centimeters) of reflective material. The maximum dimension of the test surface shall not be greater than 1.5 times the minimum dimension.

(5) **DURABILITY.** The reflective and fluorescent materials shall be tough, flexible and of sufficient thickness and strength to meet all specifications. After the durability test, 22.04 (2), the fluorescent and reflective material shall show no appreciable discoloration, cracking, crazing, blistering, loss of durable bond, or dimensional change.

(5a) **BACKING MATERIALS.** Backing material for portable identification emblems shall be equivalent to 0.040 in. (0.1016 millimeters) minimum thickness aluminum, 22-gauge (0.030 in. or 0.76 mm) minimum thickness mill-galvanized or coated sheet steel, ¼ inch minimum thickness exterior type high density overlaid soft wood plywood meeting U.S. Product Standard PSI-66 as established by the National Bureau of Standards, with the surface clean and receptive to a durable bond. The backing material shall be free of burrs.

History: Cr. Register, December, 1969, No. 168, eff. 1-1-70.

Note: The 1969 SAE Handbook may be obtained from the Society of Automotive Engineers, 485 Lexington Avenue, New York, NY 10017, and the publication product standard PS 1-66 may be obtained from Superintendent of Documents, U.S. Government Printing Office, Washington, DC 20402, and the standards are also on file in the office of the Division of Motor Vehicles, the Secretary of State, and the Revisor of Statutes.

**MVD 22.04 Test procedures.** (1) **STANDARDS.** The emblem shall be tested in conformance with the following sections from SAE J575d, Tests for Motor Vehicle Lighting Device and Components:

Section B—Samples for Tests

Section D—Laboratory Facilities

Register, June, 1982, No. 318

Section E—Vibration Test

Section H—Corrosion Test (pertains to face of emblem only)

(2) DURABILITY TEST. (a) Samples shall be exposed to the sun at an angle of 45 deg. to horizontal and facing south.

**TABLE 2**  
**Durability Test Periods**

Location	Minimum Test Period, Months	
	Fluorescent	Reflective
Outside in Midwest .....	12	24
or .....		
Outside in Miami, Florida .....	6	12

(b) The specimens shall be mounted so as not to cast shadows on each other, or contact each other, or any metallic material, or any material capable of acting as a wick. They also shall be mounted so that the products of weathering and rain water drippings shall not flow from one specimen to another.

(3) DROP TEST. Each test sample shall be dropped from a height of 5 ft. (1.53m) to a smooth hard surface equivalent to rigid metal or concrete. Each test sample shall be submitted to 3 drop tests: corner drop, edge drop and flat drop. Failure shall be considered to have occurred when the emblem will no longer meet requirements in MVD 22.03.

History: Cr. Register, December, 1969, No. 168, off. 1-1-70.

**MVD 22.05 Mounting.** (1) The emblem shall be mounted point up (see Fig. 1) in a plane perpendicular to the direction of travel plus or minus 10°. It shall be placed centrally at the rear of the vehicle securely mounted, unobscured, and 2 to 6 ft. above the ground measured from the lower edge of the emblem. It may be permanently attached to equipment when practical.

(2) The emblem shall not replace such warning device as tail lamps, reflectors, flashing lights, or warning flags now required by law and is not to be used as a clearance marker for wide equipment.

History: Cr. Register, December, 1969, No. 168, off. 1-1-70.