

Chapter NR 112

WELL CONSTRUCTION AND PUMP INSTALLATION

NR 112.01	Purpose	NR 112.13	Springs
NR 112.02	Applicability	NR 112.14	Surface protection
NR 112.03	Definitions	NR 112.15	Miscellaneous well construction and pump installation requirements
NR 112.04	Approved comparable construction	NR 112.16	Samples and reports
NR 112.05	Existing installations	NR 112.17	Pump installation and construction
NR 112.06	Contracts for nonconforming installations	NR 112.18	Well construction equipment
NR 112.07	Well location	NR 112.19	Concrete and grout mixtures
NR 112.08	Drilled type well design and construction	NR 112.20	Well disposal of pollutants
NR 112.09	Bored type well design and construction	NR 112.21	Abandonment of wells
NR 112.10	Driven point type well design and construction	NR 112.22	Cooperation with the department
NR 112.11	Dug type well design and construction	NR 112.23	Standards for existing installations
NR 112.12	Reconstructing dug type wells	NR 112.24	Severability
		NR 112.25	Effective date

History: Chapter NR 112 as it existed on September 30, 1975 was repealed and a new Chapter NR 112 was created effective October 1, 1975.

NR 112.01 Purpose. The purpose of this chapter is to establish uniform minimum standards and methods of procuring and protecting an adequate supply of ground water safe and fit for human consumption and for the preparation of food products through adequate construction or reconstruction of wells and reservoirs, installation of pumping equipment, or other methods approved by the department, in conformity with chapter 162, Wisconsin Statutes. This chapter shall govern the location, construction or reconstruction and maintenance of wells and reservoirs, the installation and maintenance of pumping and treatment equipment, and the supervision of well drillers and pumping equipment installers.

History: Cr. Register, June, 1975, No. 234, eff. 10-1-75.

NR 112.02 Applicability. The provisions of this chapter shall apply to all new and existing wells, including the reconstruction, rehabilitation or reactivation of such wells which are intended or used for supplying water for human consumption or in the production and preparation of food products, excepting those for public utilities, institutions, jointly owned systems or privately owned utility systems serving 10 or more premises of mixed ownership, schools with 3 or more rooms and all other new and existing wells to be constructed, reconstructed, rehabilitated or reactivated on one property, whose operating capacity, either singly or in the aggregate with that of other wells on the property will be in excess of 70 gallons per minute.

Note: An approval from the department is required pursuant to sections 144.025 (2) (e) and 144.04, Wisconsin Statutes, prior to construction of any well and installation of any pump not governed by this code.

History: Cr. Register, June, 1975, No. 234, eff. 10-1-75.

NR 112.03 Definitions. For the purpose of this chapter the following terms are defined as follows:

Register, June, 1975, No. 234
Environmental Protection

(1) "Absorption pond" means an earth structure constructed for the purpose of slow disposal of treated sewage or other liquid wastes by soil seepage.

(2) "Adequate water supply" means a water supply which has a yield, where obtainable, and the pump capacity to provide the quantity of water which the user has stated is necessary for drinking, culinary, food processing and other purposes for which the water is intended to be used.

(3) "Animal enclosure" means a fenced yard or similar uncovered structure in which an area of 600 square feet or less is provided for each animal unit contained therein and in which animals are enclosed for any part of at least 30 separate days per year.

(4) "Animal lot" means a fenced yard or similar uncovered structure in which the concentration of livestock or poultry is such that a vegetative cover is not maintained.

(5) "Animal shelter" (paved) means a paved covered structure including but not limited to a house or barn in which animals are enclosed for at least any part of 30 separate days per year.

(6) "Animal shelter" (unpaved) means unpaved covered structures including but not limited to houses or barns in which animals are enclosed for at least any part of 30 separate days per year.

(7) "Animal unit" means an equivalent of 1,000 pounds of live animal weight.

(8) "Animal yard" means fenced in dirt or concrete area in which cattle or other livestock or poultry are enclosed and includes animal enclosures, animal lots, and animal shelters defined in NR 112.03 (3), (4) and (5) above.

(9) "Annular space" means the space between 2 concentric cylinders or circular objects, such as the space between an upper enlarged drillhole and initial protective casing pipe or between the initial protective casing pipe and an outer construction pipe or inner liner pipe or between an inner liner pipe and lower drillhole.

(10) "Approval" means the written approval of the department.

(11) "Cistern" means a covered tank in which rainwater from roof drains is stored.

(12) "Clay slurry" means a fluid mixture of native clay formation or commercial clay or clay mineral products and water prepared with only the amount of water necessary to produce fluidity.

(13) "Contaminant" means any matter which may render water bacteriologically or chemically impure or turbid so as to make it unfit for human consumption.

(14) "Clear water waste" means cooling water and condensate drainage from refrigeration compressors and air-conditioning equipment, waste water drainage from equipment chilling processes, foundation drainage water and other water having no impurities or where impurities are of such minimum concentration as not to be

considered harmful and cooled condensate from steam heating systems or other equipment.

(15) "Drainage system" means the piping within public or private premises, which conveys sewage, rainwater or other liquid wastes to the point of disposal, but does not include the mains of a public sewerage system or private or public sewage treatment plant.

(16) "Department" means the department of natural resources.

(17) "Drawdown" means the extent of lowering of the water level or water pressure in a well when water is pumped or flows from it.

(18) "Lower drillhole" means that part of a drillhole below the vertical zone of contamination.

(19) "Upper drillhole" means that part of the cased drillhole, augerhole or excavation constructed through the vertical zone of contamination.

(20) "Upper enlarged drillhole" means that portion of upper drillhole, larger in diameter than the protective well casing and extending through all or part of the vertical zone of contamination.

(21) "Driven point well" means a well constructed by joining a "drive point" with a length of pipe, extended as may be necessary, and driving the assembly into the ground, without a preliminary excavation in excess of 10 feet in depth. All other types of wells, including those constructed by a combination of jetting and driving, are drilled type wells.

(22) "Established grade" means the permanent point of contact of the ground or artificial surface with the casing pipe or curbing of the well.

(23) "Established ground surface" means the permanent elevation of the surface of the site of the well.

(24) "Existing installations" means those made prior to April 10, 1953.

(25) "Regional flood" means a flood determined by the department to be representative of large floods known to have generally occurred in Wisconsin and which may be expected to occur on a particular stream because of like physical characteristics. The regional flood generally has an average frequency of the 100-year recurrence interval flood.

(26) "Flood plain", for the purpose of this chapter, means the land adjacent to a body of water which has been or may be hereafter covered by the regional flood.

(27) "Floodway", for the purpose of this chapter, means the channel of a stream and those portions of the flood plain adjoining the channel that are required to carry and discharge the flood waters or flood flows of any river or stream associated with the regional flood.

(28) "Flushing" means the act of causing a rapid flow of water from a well by pumping, bailing or similar operation.

(29) "Grease basin" means a watertight tank installed underground for the collection and retention of grease from cooking or food processing and which is accessible for periodic removal of the contents.

(30) "Ground water" means that part of subsurface water which is in the zone of saturation.

(31) "Holding tank" means a watertight receptacle approved by the department of health and social services for the retention of sewage.

(32) "Institution" means a state, county or municipal care or corrective facility, such as a hospital, prison, jail or home.

(33) "Liner pipe" means either protective well casing pipe installed subsequent to initial construction to seal off a zone of bacterial or chemical contamination or casing pipe installed during or subsequent to the initial well construction to seal off a caving formation.

(34) "Liquid manure holding tank" means a completely fabricated structure with or without a cover either formed in place or transported to the site, used for containing animal wastes consisting of excreta, leachings, feed losses, litter, washwaters or other associated wastes.

(35) "Near-surface water" means water in the zone immediately below the ground surface. It may include seepage from barnyards, leaching pools and disposal beds or leakage from sewers, drains and similar sources of contaminated water.

(36) "Permit" means a written approval issued by the department.

(37) "Preparation of food products" means washing, cooling, cooking, pasteurizing, bottling, canning, or otherwise preparing food for human consumption, and including the washing of utensils and equipment used in production or preparation of food.

(38) "Private water supply" means one or more sources of ground water, including facilities for storage and conveyance thereof, such as wells, springs, pumps, pressure tanks and reservoirs, on one property, other than those serving a municipality, sanitary district, utility district, institution or a jointly owned system or private utility system for 10 or more premises of mixed ownership.

(39) "Privy" means a building structure used for the deposition of human body wastes.

(40) "Protective well casing" means pipe meeting standards specified in NR 112.08(2), which is driven or set to seal off the vertical zone of contamination.

(41) "Pump installer" means any person, firm or corporation who is duly registered as such with the department, has paid the annual registration fee and has obtained a permit to engage in pump installing.

(42) "Pumping water level" means the elevation of the surface of the water in a well or water pressure at the top of a flowing artesian well after a period of pumping or flow at the customary rate.

(43) "Retention pond" means an excavated or diked structure or combination of structures designed for interception and temporary storage of runoff water contaminated by leachings, washwaters or similar liquid wastes on farms or on other property where cattle or other livestock are raised.

(44) "Reservoir" means a facility for storage of water for drinking or culinary purposes constructed entirely or partially below the ground surface.

(45) "Safe water" means water that is free from contaminating matter.

(46) "Sanitary condition" (a) When referring to a well or reservoir means that the construction of the well or reservoir and the installation of the pumping equipment are such that the well or reservoir is effectively protected against entrance of contaminating matter.

(b) When referring to the surroundings of a well or reservoir means that the location and the surrounding area are free from debris or filth of any character and not subject to flooding.

(47) "Seepage bed" means an excavated area similar to a seepage trench but larger than 3 feet in width and containing more than one distribution line.

(48) "Seepage pit" means an underground receptacle so constructed as to permit disposal of septic tank effluent, milkhouse washwater, silage juices, clear water wastes and similar wastes by soil absorption through its walls and bottoms.

(49) "Seepage trench" means an area excavated 3 feet or less in width which contains a bedding of aggregate and a single distribution line.

(50) "Septic tank" means a watertight tank which receives sewage.

(51) "Sewage" means any water carried wastes created in and conducted away from residences, industrial establishments and public buildings with such surface or ground water as may be present and for the purpose of these rules includes any other liquid wastes except clear water wastes.

(52) "Sewer" means any conduit used or intended to be used for conveying sewage.

(53) "Sanitary building sewer" means that part of the plumbing system beginning at the immediate outside foundation or proposed foundation wall and extending to its connection with the main of a public sewer, private sewer, private sewage disposal system or other point of disposal.

(54) "Sanitary building drain" means the lowest horizontal piping of a drainage system which receives the discharge from soil, waste and other drainage pipes inside any building and conveys same to the building sewer by gravity flow. The minimum building drain extends from the building sewer to all soil stacks.

(55) "Sanitary building subdrain" means the horizontal portion of a drainage system within a building which cannot flow by gravity to the building drain.

(56) "Solid manure storage structure" means a structure used for stacking or composting and containment of animal wastes consisting of excreta, feed losses, litter or associated solid wastes.

(57) "Specific capacity" means the continuous yield of a well at a given well water or pressure drawdown expressed in gallons per minute, per foot of drawdown.

(58) "Static water level" means that elevation of the surface of the water in a well or water pressure at the top of a well, in the case of some artesian wells, when no water is being pumped or flows therefrom. In the case of artesian wells with a positive water pressure at the top of the well, the static water elevation is determined either by a stilling pipe or pressure gauge and under either condition water elevations are referred to the elevation of the top of the well or the ground grade at the well.

(59) "Storm sewer" means any conduit used or intended to be used for conveying surface water runoff, clear water waste and subsoil drainage with such ground water as may be present.

(60) "Storm building sewer" means that part of the storm water system which receives the discharge from building storm drains and sub-drains, parking lots, yard fountains and other similar sources, and conveys such waters to a public storm water system, private storm water system or other approved point of disposal.

(61) "Storm building drain" means the lowest horizontal piping which receives storm waters or other similar water from roofs, area ways, courtyards, canopies, enclosed parking ramps and other sources inside any building or structure and conveys same to the storm building sewer by gravity flow.

(62) "Storage pond" means an excavated or diked earthen structure including partially fabricated liquid manure holding tanks designed for containing animal wastes consisting of excreta, leachings, feed losses, litter, washwaters or other associated liquid wastes.

(63) "Stuffing box" means an approved receptacle in which packing may be compressed to form a watertight or airtight junction between 2 objects.

(64) "Subsoil drain" means that part of the drainage system which conveys the ground or seepage water from the footings of walls or below the basement floor under buildings to the storm sewer or other point of disposal.

(65) "Sump" means a tank or pit which receives sewage or other liquid wastes located below the normal grade of a gravity system and which must be emptied by mechanical means.

(66) "Treatment pond" means an earth structure with sealed bottom and walls constructed for the purpose of holding sewage or other liquid waste for a period of time to reduce BOD and suspended solids.

(67) "Vertical zone of contamination" means that depth of geologic formations, generally near the ground surface, containing connecting pore spaces, crevices or similar openings, including artificial channels, such as unprotected wells, through which contaminated water may gain access to a well or the ground water body.

(68) "Watertight construction" means cased and grouted construction through firm formations like clay or rock. Through granular material like sand or gravel, it means that the casing pipe is of approved quality and assembled watertight.

(69) "Well" means an excavation or opening into the ground made by digging, boring, drilling, driving or other methods for the purpose of obtaining ground water for human consumption.

(70) "Well cap" means an approved removable non-watertight apparatus or device used to cover a well.

(71) "Well driller" means any person, firm or corporation who has duly registered as such with the department, has paid the annual registration fee and has obtained a permit to construct wells.

(72) "Well seal" means an approved removable apparatus or device used as follows:

(a) To close the well opening watertight or to establish and maintain a watertight junction between the upper terminal of protective casing or curbing of a well and the piping or equipment installed therein, so as to prevent water from entering the well; or

(b) To establish and maintain a watertight junction between the basement end of non-pressure pipe conduit, installed between a well and a building basement, and the pump piping installed within the conduit.

(73) "Well vent" means an outlet at the upper end of the well casing or basement end of a non-pressure conduit to allow equalization of air pressure in the well.

(74) "Yield" means the quantity of water which may flow or be pumped from the well per unit of time.

History: Cr. Register, June, 1975, No. 234, eff. 10-1-75; renum. (55) to (73) to be (56) to (74), cr. (55), Register, March, 1977, No. 255, eff. 4-1-77.

NR 112.04 Approved comparable construction. When strict compliance with this chapter appears to be impracticable, the reasons therefor shall be communicated in writing to the department for advice and approval of comparable specifications.

History: Cr. Register, June, 1975, No. 234, eff. 10-1-75.

NR 112.05 Existing installations. Existing well, pump, pressure tank, pit, subsurface pumproom and reservoir installations that conform to section NR 112.23 are acceptable. Noncomplying existing well, pump, pressure tank, pit, subsurface pumproom and reservoir installations shall be corrected to comply with NR 112.23 or the specifications in this chapter for new construction.

History: Cr. Register, June, 1975, No. 234, eff. 10-1-75.

NR 112.06 Contracts for nonconforming installations. Well drillers and pump installers shall ensure that the construction and reconstruction of wells or appurtenances thereto or the installation of pumping equipment adheres to all the applicable provisions of this chapter or to approved comparable requirements. Well drillers and pump installers shall not enter into any agreement, written or oral, for such construction, reconstruction or installation which does not require compliance with all applicable provisions of this chapter or with approved comparable requirement.

History: Cr. Register, June, 1975, No. 234, eff. 10-1-75.

NR 112.07 Well location. (1) **GENERAL.** Where a well is constructed to supply ground water for human consumption and preparation of food products, such well shall be located:

(a) In such manner that the well and its surroundings can be kept in a sanitary condition.

(b) At the highest point on the premises consistent with the general layout and surroundings, but in any case protected against surface water flow and flooding.

(c) As far removed from any known or probable source of contamination as the general layout of the premises and the surroundings permit.

(2) **RELATION TO CONTAMINATION SOURCES.** Unless modified by written department approval under NR 112.04, minimum separating distances between wells or reservoirs and sources of contamination shall be maintained as follows:

(a) Eight feet between well or reservoir and cast iron or equivalent sanitary or storm building sewer or sanitary or storm building drain or a basement floor drain connected to a cast iron or equivalent sanitary building sewer or sanitary building drain; cast iron or equivalent subdrain; cast iron or equivalent sewage sump; cast iron or equivalent milkhouse floor drain; cast iron or equivalent drain from a conventional silo or glass lined storage facility, cast iron or equivalent sewer conducting manure juices to point of disposal.

(b) Ten feet between well and independent clear water waste drain, rainwater downspout outlet, cistern, hydrant drain, or similar unit; building foundation-drain connected to independent clear water waste drain or other subsoil drain; nonconforming existing or unapproved new well pit, pump pit, pressure-tank pit, pressure-tank access pit or subsurface pumphoom; nonconforming reservoir.

(c) Fifteen feet between well and sewer-connected foundation drain.

(d) Twenty-five feet between well or reservoir and watertight grease basin, septic tank, holding tank, subdrain other than cast iron or equivalent pipe; sewage sump other than cast iron or equivalent material; sanitary building or storm building sewer other than cast iron or equivalent material; sanitary building or storm building drain other than cast iron or equivalent material; floor drain connected to sanitary building sewer or drain of other than cast iron or equivalent pipe material; lake or stream shoreline; below-ground swimming pool.

Register, March, 1977, No. 255
Environmental Protection

(e) Twenty-five feet between well or reservoir and watertight barn gutter; animal barn pen with concrete floor; glass-lined storage facility without pit; conventional silo without pit but with concrete floor and proper drain; watertight, milkhouse floor drain other than cast iron or equivalent material; watertight, conventional silo drain or glass-lined storage facility drain other than cast iron or equivalent material; watertight sewer other than cast iron or equivalent material conveying manure juices.

(f) Twenty-five feet between well or reservoir and a pressurized sewer, other than a street sanitary or storm sewer or similar sanitary or storm sewer piping comprising part of the drainage system on public or private property, for which the required minimum separating distance between a well or reservoir and such sewers is specified in NR 112.07 (2) (h).

(g) Fifty feet between well or reservoir and seepage pit, seepage bed, seepage trench or other similar sewage or waste water disposal unit; privy; dog-waste pit disposal unit; animal yard, animal shelter, animal enclosure or animal lot; conventional silo with pit; glass-lined storage facility with pit; outlet of watertight milkhouse drain; seepage pit for drain of conventional silo or glass-lined storage facility; loose-jointed field-drain pipe lines.

(h) Fifty feet between well or reservoir and street sanitary or storm sewer; similar sanitary or storm sewer piping comprising part of the drainage system on public or private property.

(i) One hundred feet between well or reservoir and a temporary manure stack; solid manure storage structure; watertight reinforced poured concrete or equivalent concrete fabricated liquid-manure holding tank; earthen silage storage trench or pit.

(j) One hundred feet between well or reservoir and bulk subsurface storage tanks for refined petroleum products such as gasoline and fuel oil, except in the case of fuel oil tanks for private residential use, in which case the separating distance shall be at least 25 feet or farther where practical.

(k) One hundred feet between well or reservoir and nearest existing or future grave sites in cemeteries.

(l) Two hundred feet between well or reservoir and sludge disposal area on same property or adjoining property.

(m) Two hundred fifty feet between well or reservoir and an absorption, storage, retention or treatment pond; ridge and furrow waste disposal site; or a spray irrigation waste disposal site.

(n) Four hundred yards between well or reservoir and the nearest edge of an existing or proposed sanitary land fill disposal site.

(o) For the purpose of paragraphs NR 112.07 (2) (a), (d) and (e), the term "equivalent" means, as it pertains to a cast iron sewer, drain or subdrain, approved plastic pipe as listed and limited in Wis. Adm. Code chapter H 62 (State Plumbing Code) for specific uses and as it pertains to a sewage sump, a plastic sump fabricated from a plastic material approved by the division of health, department of health and social services.

(3) **RELATION TO BUILDINGS.** With respect to buildings the location of a well shall be as follows:

(a) When a well is located outside and adjacent to a building, it shall be located so that the center line of the well extended vertically will clear any projection from the building by not less than 2 feet.

(b) Every well shall be located so that it will be reasonably accessible with proper equipment for cleaning, treatment, repair, test, inspection, and such other maintenance as may be necessary.

(c) No well shall be located nor shall a building extension be constructed so that the top of the well will be within the basement of any building or building extension or under a building or building extension having no basement.

(4) **RELATION TO FLOOD PLAINS.** (a) Wells may be constructed and replaced on property on the flood plain outside of the floodway provided that the top of the well is terminated a minimum of 2 feet above the regional flood elevation for the well site.

(Note: This is the required minimum elevation of the first floor of any new building in the flood plain.)

(b) A well may be reconstructed or replaced on property in a floodway provided that a permit is first obtained from the department.

(c) No well may be constructed on floodway property that is either undeveloped or has building structures but no existing well.

Note: Attention of well drillers and pump installers is called to Volume I, of the Wisconsin State Electrical Code which can be found in Volume 4 of the Wisconsin Administrative Code, for restrictions on proximate locations of well drilling and pump installing equipment relative to electric power lines.

History: Cr. Register, May, 1975, No. 233, eff. 5-1-75; am. (2) (a), (b), (d) and (e), renun. (2) (f) to (m) to be (2) (g) to (n), cr. (2) (f) and (o), Register, March, 1977, No. 255, eff. 4-1-77.

NR 112.08 Drilled type well design and construction. (1) **GENERAL.** The construction of every well shall be planned and carried out so that it will be:

(a) Adapted to the geologic (earth structure) and ground water conditions existing at the site of the well so as to insure full utilization of every natural protection afforded thereby against contamination of water bearing formations and to exclude known sources of contamination.

(b) Designed to permit such supplementary construction as may be required to provide a sufficient and safe water supply, where obtainable, and to conserve ground water.

(c) Capable of satisfying where obtainable, the yield requirements of an "adequate water supply".

(2) **SPECIFIC.** The requirements of NR 112.08(1) for drilled-type wells shall be deemed to be fulfilled when minimum construction and material requirements set forth in table 1 and in paragraphs (a) through (i) below are met. (Note: See Appendix figures A1 through A25.)

TABLE I
DRILLED TYPE WELL REQUIREMENTS

1	2	3	4	UPPER DRILLHOLE				10	11		
				UPPER ENLARGED DRILLHOLE		REGULAR DRILLHOLE	LOWER DRILLHOLE			MAXIMUM NOMINAL PROTECTIVE	
				MINIMUM DIAMETER	MINIMUM DEPTH	MINIMUM DIAMETER	BOTTOM ELEVATION			MINIMUM WELL DIAMETER	LINER DIAMETER
5	6	7	8	9	CONSTRUCTION CONDITIONS						
a.	Sand or gravel	Sand or mixture of sand and gravel.	2"	None required with cable tool drilling but shall be casing diameter plus 1/4" if rotary drilling. See construction conditions. Casing diameter plus 2" with rotary drilling.	None required with cable tool drilling. To depth of casing setting with rotary drilling.	2"	See Construction Conditions			The depth of protective well casing pipe will be governed by the pumping level. For pumping levels 20' or less the casing shall extend 10' below the pumping level. For pumping levels 20' to 25' the casing shall extend to a depth of 30'. For pumping levels greater than 25' the casing shall extend 5' below the pumping level. When an enlarged upper drillhole is constructed with cable tool equipment, the annular space shall be filled with clay slurry or cement grout placed in an approved manner. See Note 2 below. With rotary drilling, the upper enlarged drillhole shall be maintained at full diameter with drilling mud and the annular space shall be permanently sealed with drilling mud or cement grout. See Note 1 below. Also see Appendix.	a, b, c Protective well casing placed in an upper enlarged drillhole only 2" greater in diameter than the nominal well casing pipe diameter, as is only permissible with rotary-air drilling, shall be assembled with welded joints and sealed in place with drilling mud or cement grout placed in the annular space by a suitable pump from the bottom of the casing upward.
b.	Sand or gravel	Clay or similar material to depth of 30' or more, containing layers of sand or gravel.	2"	Casing diameter plus 1/4" with cable tool drilling. Casing diameter plus 2" with rotary drilling. See construction conditions.	5' into clay below any sand or gravel above the 20' depth with cable tool drilling. To depth of casing setting with rotary drilling.	2"	See Construction Conditions			The protective well casing pipe shall extend 5' below the pumping level. With cable tool drilling the upper enlarged drillhole shall be kept open with temporary well casing and the upper drillhole shall be kept 1/3 filled with clay slurry throughout the driving of the permanent well casing. The balance of the annular space shall be filled with clay slurry or cement grout. With rotary drilling, the upper enlarged drillhole shall be maintained at full diameter with drilling mud and the annular space shall be permanently sealed with drilling mud or cement grout. See Note 1 below. Also see Appendix.	An adequate screen shall be provided where necessary. It shall be installed in such manner that removal or replacement can be accomplished without adversely affecting the watertight construction of the well.
c.	Sand or gravel	Clay or similar material from the ground surface to varying depths.	2"	Casing diameter plus 1/4" with cable tool drilling. Casing diameter plus 2" with rotary drilling. See construction conditions.	To the bottom of the clay or a minimum of 20' whichever is the lesser with cable tool drilling. To the depth of casing setting with rotary drilling.	2"	See Construction Conditions			See (a-c) above for minimum casing depth requirements. With cable tool drilling, the upper drillhole shall be kept 1/3 filled with clay slurry throughout the driving of the permanent well casing. The balance of the annular space shall be filled with clay slurry or cement grout. With rotary drilling the upper enlarged drillhole shall be maintained at full diameter with drilling mud and the annular space shall be permanently sealed with drilling mud or cement grout. See Note 1 below. Also see Appendix.	Approval from the Department is required for a gravel-pack well construction in conformance with Section NR 112.04.

NOTE 1. Greater depth of casing is required in areas where well histories show that the vertical zone of contamination extends to a greater depth.

NOTE 2. Some drillers construct an enlarged upper drillhole to a depth of several feet with cable tool equipment by choice under geologic conditions of column 3, line a, to facilitate use of long lengths of pipe.

TABLE I
DRILLED TYPE WELL REQUIREMENTS

1 TYPE	2 NATURE OF WATER BEARING FORMATION (AQUIFER)	3 GEOLOGIC FORMATION OVERLYING AQUIFER	4 MINIMUM NOMINAL CASING DIAMETER INCHES	5 UPPER DRILLHOLE				9 LOWER DRILLHOLE MINIMUM WELL DIAMETER	10 MAXIMUM NOMINAL PROTECTIVE LINER DIAMETER	11 CONSTRUCTION CONDITIONS
				6 UPPER ENLARGED DRILLHOLE		7 REGULAR DRILLHOLE				
				8 MINIMUM DIAMETER	MINIMUM DEPTH	MINIMUM DIAMETER	BOTTOM ELEVATION			
d.	Limestone (See Note 3)	Unconsolidated materials, mainly sand or gravel, to depth of at least 40' to a radius of ½ mile. No record of sink holes, test holes, quarries or abandoned wells in above area.	6"	Casing diameter plus 4" if one is constructed with cable tool drilling. To rock with rotary drilling. See construction conditions. Casing diameter plus 2" with rotary drilling.	None required with cable tool drilling. To rock with rotary drilling.	6" with cable construction tool drillings. Not applicable with rotary drilling.	See construction conditions.	6"	2" less than the lower drillhole diameter.	The protective well casing pipe shall be firmly seated in the rock formation. When an upper enlarged drillhole is constructed with cable tool equipment, the annular space shall be filled with clay slurry or cement grout placed in an approved manner. See Note 2 below. With rotary drilling, the upper enlarged drillhole shall be maintained at full diameter with drilling mud or with temporary well casing and the annular space shall be permanently sealed with drilling mud or cement grout, except that only cement grout shall be used when the upper enlarged drillhole is constructed more than 2' into the limestone. The vertical zone of contamination must be sealed off. See Note 1 below. Also see Appendix
e.	Limestone (See Note 3)	Clay or similar material or such materials with some sand and gravel zones to depth of at least 40' to a radius of ½ mile. No record of sink holes, test holes, quarries or abandoned wells in above area.	6"	Casing diameter plus 4" with cable tool drilling. Casing diameter plus 2" with rotary drilling. See construction conditions.	To the bottom of the clay or to the 40' depth, whichever is the lesser, with cable tool drilling. To rock with rotary drilling. See construction conditions.	6" with cable construction tool drillings. Not applicable with rotary drilling.	See construction conditions.	6"	2" less than the lower drillhole diameter.	The protective well casing pipe shall be firmly seated in the rock formation. With cable tool drilling, the upper enlarged drillhole shall be kept open by temporary well casing, when necessary and shall be kept 1/8" filled with clay slurry throughout driving of the protective well casing. The balance of the annular space shall be filled with clay slurry or cement grout applied in an approved manner. Construction conditions for drilling with rotary equipment are the same as above for line d. The vertical zone of contamination must be sealed off. See Note 1 below. Also see Appendix.
f.	Limestone (See Note 3)	Unconsolidated materials for depth less than 40' within a radius of ½ mile. No record of sink holes, test holes, quarries or abandoned wells in above area.	6"	Casing diameter plus 4" with cable tool drilling. Casing diameter plus 2" with rotary drilling. See construction conditions.	10' into unconsolidated rock below 40'.	6" with cable construction tool drillings. Not applicable with rotary drilling.	See construction conditions.	6"	2" less than the lower drillhole diameter.	The upper enlarged drillhole through casing formations above the rock shall be kept open by temporary well casing with cable tool drilling and with such casing or drilling mud with rotary drilling. If the formation over the rock is clay or material which will inherently stand open, with rotary drilling the drill cuttings preferably shall be removed by circulating mud but use of air will be permitted for such geologic formations. The annular space shall be permanently filled with cement grout. The vertical zone of contamination must be sealed off. See Note 1 below. Also see Appendix.

NOTE 1. Casing only to rock under conditions of column 3, lines d & e and to the depth indicated in column 6, line f for condition of column 3, line f, is only acceptable as a minimum when it is adequate to seal off the vertical zone of contamination. Greater depth of protective casing is required in areas where well histories show that the vertical zone of contamination extends to a greater depth.

NOTE 2. Some drillers construct an enlarged upper drillhole with cable tool equipment by choice under geologic conditions of column 3, line d, to facilitate use of longer lengths of pipe.

NOTE 3. Although the carbonate rocks in this state are primarily dolomites, the term limestone has been given to them in the well construction specifications because it is the common term given to them by drillers.

TABLE I
DRILLED TYPE WELL REQUIREMENTS

1	2	3	4	5				6	7	8	9	10	11		
				UPPER ENLARGED DRILLHOLE		REGULAR DRILLHOLE								LOWER DRILLHOLE	MAXIMUM NOMINAL PROTECTIVE LINER DIAMETER
				MINIMUM DIAMETER	MINIMUM DEPTH	MINIMUM DIAMETER	BOTTOM ELEVATION							WELL DIAMETER	LINEAR DIAMETER
g.	Shale (See Note 3)	Unconsolidated materials, mainly sand or gravel, to depth of at least 40' to a radius of 1/2 mile.	6"	Casing diameter plus 4" if one is constructed with cable tool drilling. See construction conditions. Casing diameter plus 2" with rotary drilling.	None required with cable tool drilling. To shale with rotary drilling.	6" with cable tool drilling. Not applicable with rotary drilling.	See construction conditions.	6"	2" less than the lower drillhole diameter.	The protective well casing pipe shall be firmly seated in the shale formation. When an upper enlarged drillhole is constructed with cable tool equipment, the annular space shall be filled with clay slurry or cement grout placed in an approved manner. See Note 2 below. With rotary drilling, the upper enlarged drillhole shall be maintained at full diameter with drilling mud or temporary well casing and the annular space shall be permanently sealed with drilling mud or cement grout, except that only cement grout shall be used when the upper enlarged drillhole is constructed more than 2' into the shale. The vertical zone of contamination must be sealed off. See Note 1 below. Also see Appendix.	g.h	Protective well casing pipe placed in an upper enlarged drillhole only 2" greater in diameter than the nominal well casing pipe diameter, as is only permissible with rotary-air drilling, shall be assembled with welded joints and sealed in place with drilling mud or cement grout placed in the annular space by a suitable pump from the bottom of the casing upward.			
h.	Shale (See Note 3)	Clay or similar material or such materials with some sand and gravel comes to a depth of at least 40 feet to a radius of 1/2 mile.	6"	Casing diameter plus 4" with cable tool drilling. Casing diameter plus 2" with rotary drilling. See construction conditions.	To the bottom of the clay or to the 20' depth, whichever is the lesser, with cable tool drilling. To shale with rotary drilling.	6" with cable tool drilling. Not applicable with rotary drilling.	See construction conditions.	6"	2" less than the lower drillhole diameter.	The protective well casing pipe shall be firmly seated in the shale formation. With cable tool drilling, the upper enlarged drillhole shall be kept open with temporary well casing, when necessary, and shall be kept 1/3 filled with clay slurry throughout the duration of the protective casing. The balance of the annular space shall be filled with clay slurry or cement grout applied in an approved manner. Construction conditions for drilling with rotary equipment are the same as above for line g. The vertical zone of contamination must be sealed off. See Note 1 below. Also see Appendix.	g.h.i	Protective liner pipe shall be assembled with welded joints, placed concentrically within the drillhole and sealed in place with cement grout placed by a suitable pump or other approved method from the bottom of the liner pipe upward.			
i.	Shale (See Note 3)	Unconsolidated materials or limestone beds or without unconsolidated formations above to a depth of less than 40' within a radius of 1/2 mile. No record of abandoned wells or test holes within the area.	6"	Casing diameter plus 4" with cable tool drilling. Casing diameter plus 2" with rotary drilling. See construction conditions.	40 feet	Not applicable	See construction conditions.	6"	2" less than the lower drillhole diameter.	The upper enlarged drillhole through casing formations above the rock shall be kept open by temporary well casing with cable tool drilling and by such casing or drilling mud with rotary drilling. If the unconsolidated formation over the rock is clay or material which will stifferly stand open, with rotary drilling the drill outlines preferably shall be removed by mud but use of air will be permitted for such geologic formations. The annular space surrounding the well casing shall be permanently filled with cement grout. The vertical zone of contamination must be sealed off. See Note 1 below. Also see Appendix.		The upper enlarged drillhole diameter need be only 2" greater than the nominal well casing pipe diameter when the well casing pipe is assembled with welded joints and the cement grout is placed in the annular space by a suitable pump or other approved pressure method from the bottom of the casing upward.			

NOTE 1. Casing only to shale under conditions of column 3, lines g & h and to the depth indicated in column 6, line 1, for condition of column 3, line 1, is only acceptable as a minimum when adequate to seal off the vertical zone of contamination. Greater depth of protective casing is required in areas where well histories show that the vertical zone of contamination extends to a greater depth.

NOTE 2. Some drillers construct an enlarged upper drillhole with cable tool drilling equipment by choice under geologic conditions of column 3, line g, to facilitate use of longer lengths of pipe.

NOTE 3. Wells normally shall not be developed into a shale formation. Such constructions are limited primarily to "Maspokena" shale where the limestone is missing or very thin but only when the shale is known to be firm enough so that the drillhole will remain open and the water therefrom is not turbid. These wells may occur along the western edge of the Niagara dolomite extending from Door County to the Illinois border, at Blue Mound, at the Plattville Mound and in the Sinsinawa area in Grant County. Shale wells under similar geologic conditions in other areas of the state where overlying rock is missing or thin will also be acceptable.

TABLE 1
DRILLED TYPE WELL REQUIREMENTS

1	2	3	4 MINIMUM NOMINAL CASING DIAMETER INCHES	5 UPPER DRILLHOLE			8 MINIMUM BOTTOM ELEVATION FEET	9 LOWER DRILLHOLE MINIMUM WELL DIAMETER	10 MAXIMUM PROTECTIVE LINER DIAMETER	11 CONSTRUCTION CONDITIONS	
				5 MINIMUM DIAMETER	6 MINIMUM DEPTH	7 REGULAR DRILLHOLE MINIMUM DIAMETER					
j	Granite or Quartzite (See Note 1)	Unconsolidated materials mainly sand or gravel, to depth of at least 40' to a radius of 1/2 mile.	6"	Casing diam- eter plus 1/2" with cable tool. To rock with rotary drilling. See construction conditions. Casing diam- eter plus 2" with rotary drilling.	None required with cable tool. To rock with rotary drilling.	6" with cable tool drilling. Not applica- ble with rotary drilling.	See con- struction condi- tions.	6"	2" less than the lower drillhole diameter.	The protective well casing pipe shall be firmly seated in the rock formation. When an enlarged upper drillhole is constructed with cable tool equipment, the annular space shall be filled with clay slurry or cement grout placed in an approved manner. See Note 2 below. With rotary drilling equipment, the upper enlarged drillhole shall be maintained at full diameter with drilling mud or temporary well casing and the annular space shall be permanently sealed with drilling mud or cement grout, except that only cement grout shall be used when the upper enlarged drillhole is con- diametered more than 2" into the granite. The vertical zone of contamination must be sealed off. See Note 3 below. Also see Appendix.	j,k Protective well casing pipe placed in an upper enlarged drillhole only 2" greater in diameter than the nominal well casing pipe diameter, as is only permissible with rotary-air drilling, shall be assembled with welded joints and sealed in place with drilling mud or cement grout placed in the annular space by a suitable pump from the bottom of the casing upward.
k	Granite or Quartzite (See Note 1)	Clay or similar material or such materials with some sand and gravel zones to a depth of at least 40' to a radius of 1/2 mile.	6"	Casing diam- eter plus 1/2" with cable tool drilling. Casing diam- eter plus 2" with rotary drilling. See construction conditions.	To the bottom of the clay or to the 20' depth whichever is the lesser with cable tool drilling. To rock with rotary drilling.	6" with cable tool drilling. Not applica- ble with rotary drilling.	See con- struction condi- tions.	6"	2" less than the lower drillhole diameter.	The protective well casing pipe shall be firmly seated into the rock formation. With cable tool drilling the upper enlarged drillhole shall be kept open with temporary well casing, when necessary, and shall be kept 1/4 filled with clay slurry throughout the driving of the protective casing. The balance of the annular space shall be filled with clay slurry or cement grout applied in an approved manner. Construction conditions for drilling with rotary equipment are the same as above for line j. The vertical zone of contamina- tion must be sealed off. See Note 3 below. Also see Appendix.	j,k,l Protective liner pipe shall be assembled with welded joints, placed concentrically within the drillhole and sealed in place with cement grout placed by a suitable pump or other approved method from the bottom of the liner pipe upward.
l	Granite or Quartzite (See Note 1)	Unconsolidated materials for depth less than 40' within a radius of 1/2 mile.	6"	Casing diam- eter plus 1/2" with cable tool drilling. Casing diam- eter plus 2" with rotary drilling. See construction conditions.	40'. See construction conditions for exceptions.	Not applica- ble.		6"	2" less than the lower drillhole diameter.	Normally 10' of slip is required to seal off the vertical zone of contamination. An attempt shall be made to obtain water below 40' and at least to a depth of 75' even though water is usually may be encountered during drilling at a depth above 40'. Should an adequate water producing zone not be encountered below 40' and down to a depth of 75' or lower, consideration may be given by the Department to permit protection of the water above 40'. Department approval is required for such well. Other construction conditions are the same as for line j. The vertical zone of contamination must be sealed off. See Note 3 below. Also see Appendix.	l The upper enlarged drillhole diameter need be only 2" greater than the nominal well casing pipe diameter when the well casing pipe is assembled with welded joints and the cement grout is placed in the annular space by a suitable pump or other approved pressure method from the bottom of the casing upward.

NOTE 1. Crystalline rocks are classed as granite because they are commonly referred to as granite by drillers regardless of their true rock type. This includes trap rock.

NOTE 2. Some drillers construct an enlarged upper drillhole with cable tool equipment by choice under geologic conditions of column 3, line j, to facilitate use of longer lengths of pipe.

NOTE 3. Casing only to rock under conditions of column 3, lines j & k and to the depth indicated in column 6, line l, for condition of column 3, line l, is only acceptable as a minimum when it is adequate to seal off the vertical zone of contamination. Greater depth of protective casing is required in areas where well histories show that the vertical zone of contamination extends to a greater depth.

TABLE 1
DRILLED TYPE WELL REQUIREMENTS

1	2	3	4	UPPER DRILLHOLE				9	10	11	
				UPPER ENLARGED DRILLHOLE		REGULAR DRILLHOLE	LOWER DRILLHOLE				MAXIMUM NOMINAL PROTECTIVE LINER DIAMETER
				5	6						
TYPE	NATURE OF WATER BEARING FORMATION (AQUIFER)	GEOLOGIC FORMATIONS OVERLYING AQUIFER	MINIMUM NOMINAL CASING DIAMETER INCHES	MINIMUM DIAMETER	MINIMUM DEPTH	MINIMUM DIAMETER	BOTTOM ELEVATION	MINIMUM WELL DIAMETER	MINIMUM DIAMETER	CONSTRUCTION CONDITIONS	
m.	Sandstone	Unconsolidated materials mainly sand and gravel to a depth of 25' or more.	6"	Casing diameter plus 1" with cable tool drilling. See construction conditions. Casing diameter plus 2" with rotary drilling.	None required with cable tool. Into firm sandstone with rotary drilling.	6" with cable tool drilling. Not applicable with rotary drilling.	See construction conditions.	6"	2" less than the lower drillhole diameter.	The protective well casing pipe shall be firmly seated in the rock formation. When an upper enlarged drillhole is constructed with cable tool equipment, the annular space shall be filled with clay slurry or cement grout placed in an approved manner. See Note 2 below. With rotary drilling, the upper enlarged drillhole shall be maintained at full diameter with drilling mud or with temporary well casing and the annular space shall be permanently sealed with drilling mud or cement grout, except that only cement grout shall be used when the upper enlarged drillhole is constructed more than 2' into the sandstone. The vertical zone of contamination must be sealed off. See Note 1 below. Also see Appendix.	m.5 Protective well casing pipe placed in an upper enlarged drillhole only 2" greater in diameter than the nominal well casing pipe diameter, as is only permissible with rotary-air drilling, shall be assembled with welded joints and sealed in place with drilling mud or cement grout placed in the annular space by a suitable pump from the bottom of the casing upward.
n.	Sandstone	Clay or similar material with some sand and gravel zones to depth of 25' or more.	6"	Casing diameter plus 1" with cable tool drilling. Casing diameter plus 2" with rotary drilling. See construction conditions.	To the bottom of the clay or to the 25' depth whichever is the lesser. With cable tool drilling. Into firm sandstone with rotary drilling.	6" with cable tool drilling. Not applicable with rotary drilling.	See construction conditions.	6"	2" less than the lower drillhole diameter.	The protective well casing pipe shall be firmly seated in the rock formation. With cable tool drilling, the upper enlarged drillhole shall be kept open by temporary well casing, when necessary and shall be kept 1/3 filled with clay slurry throughout the driving of the protective casing. The balance of the annular space shall be filled with clay slurry or cement grout applied in an approved manner. Construction conditions for drilling with rotary equipment are the same as above for line m. The vertical zone of contamination must be sealed off. See Note 1 below. Also see Appendix.	n.5,6 Protective liner pipe shall be assembled with welded joints, placed concentrically within the drillhole and sealed in place with cement grout placed by a suitable pump or other approved method from the bottom of the liner pipe upward.
o.	Sandstone	Any material except limestone to a depth of less than 25'.	6"	Casing diameter plus 1" with cable tool drilling. Casing diameter plus 2" with rotary drilling. See construction conditions.	Into firm sandstone or to the 25' depth whichever is greater.	Not applicable.		6"	2" less than the lower drillhole diameter.	The upper enlarged drillhole through cavine formations above the rock shall be kept open by temporary well casings with cable tool drilling and by such casing or drilling mud with rotary drilling. If the formation over the rock is clay or material which will similarly stand open, with rotary drilling the drill cuttings preferably shall be removed by mud but use of air will be permitted for such geologic formations. The annular space surrounding the protective well casing shall be permanently filled with cement grout. The vertical zone of contamination must be sealed off. See Note 1 below. Also see Appendix.	o The upper enlarged drillhole diameter need be only 2" greater than the nominal well casing pipe diameter when the well casing pipe is assembled with welded joints and the cement grout is placed in the annular space by a suitable pump or other approved pressure method from the bottom of the casing upward.

NOTE 1. Casing only to the depth indicated in column 6, lines m, n & o, for conditions of column 3, lines m, n & o, is only acceptable as a minimum when it is adequate to seal off the vertical zone of contamination. Greater depth of protective casing is required in areas where well histories show that the vertical zone of contamination extends to a greater depth.

NOTE 2. Some drillers construct enlarged upper drillholes to a depth of several feet with cable tool equipment by choice under geologic conditions of column 3, line m, to facilitate use of longer lengths of pipe.

TABLE I
DRILLED TYPE WELL REQUIREMENTS

1	2	3	4	5				9	10	11		
				UPPER DRILLHOLE		REGULAR DRILLHOLE					LOWER DRILLHOLE	MAXIMUM NOMINAL PROTECTIVE LINER DIAMETER
				UPPER ENLARGED DRILLHOLE	MINIMUM DIAMETER	MINIMUM DEPTH	MINIMUM DIAMETER					
p.	Sandstone	Limestone to depth of 40' or less with or without unconsolidated overburden over the limestone.	6"	Casing diameter plus 4" with cable tool drilling. Casing diameter plus 2" with rotary drilling. See construction conditions.	15' into firm sandstone.	Not applicable.		6"	2" less than the lower drillhole diameter.	<p>CONSTRUCTION CONDITIONS</p> <p>The upper enlarged drillhole through saving formations above the rock shall be kept open by temporary well casing with cable tool drilling and by such casing or drilling mud with rotary drilling. If the formation over the rock is clay or material which will similarly stand open, with rotary drilling the drill outlines preferably shall be removed by mud but use of air will be permitted for such geologic formation. The annular space surrounding the protective well casing shall be permanently filled with cement grout. The vertical zone of contamination must be sealed off. See Note 1 below. Also see Appendix.</p> <p>pq Protective well casing pipe placed in an upper enlarged drillhole only 2" greater in diameter than the nominal well casing pipe diameter, shall be assembled with welded joints and sealed in place with cement grout placed in the annular space by a suitable pump from the bottom of the casing upward.</p> <p>Protective liner pipe shall be assembled with welded joints, placed concentrically within the drillhole and sealed in place with cement grout placed by a suitable pump or other approved method from the bottom of the casing upward.</p>		
q.	Sandstone	limestone extending to a depth greater than 40' with or without unconsolidated overburden over the limestone.	6"	Casing diameter plus 4" with cable tool drilling. Casing diameter plus 2" with rotary drilling. See construction conditions.	40' or 10' into uncracked rock below 30'.	Not applicable.		6"	2" less than the lower drillhole diameter.	<p>The upper enlarged drillhole diameter need be only 2" greater than the nominal well casing pipe diameter when the well casing pipe is assembled with welded joints and the cement grout is placed in the annular space by a suitable pump or other approved pressure method from the bottom of the casing upward.</p>		

NOTE 1. Although the carbonate rocks in this state are primarily dolomites, the term limestone has been given to them in the well construction specifications because it is the common term given to them by the drillers.

NOTE 2. Casing only to the depth indicated in column 6, lines p & q, for conditions of column 3, lines p & q, is only acceptable as a minimum when it is adequate to seal off the vertical zone of contamination. Greater depth of protective casing is required in areas where well histories show that the vertical zone of contamination extends to a greater depth.

(a) *Well casing pipe.* The protective well casing pipe materials shall be steel pipe having the nominal diameters and the weights as specified in table 2.

TABLE 2
MINIMUM
CASING PIPE AND COUPLING
WEIGHTS AND DIMENSIONS

Size in Inches	Wgt. Lbs. Per Ft.		Thickness in Inches	Pipe		Threads Per Inch	Couplings	
	Threads & Coupling	Plain End		Diameter - Inches External Internal	External Diameter Inches		Length in Inches	
1	1.70	1.68	.133	1.315	1.049	11-1/2	1.576	2-5/8
1-1/4	2.30	2.27	.140	1.660	1.380	11-1/2	1.900	2-3/4
1-1/2	2.75	2.72	.145	1.900	1.610	11-1/2	2.200	2-3/4
2	3.75	3.65	.154	2.375	2.067	11-1/2	2.750	2-7/8
2-1/2	5.90	5.79	.203	2.875	2.469	8	3.250	2-15/16
3	7.70	7.58	.216	3.500	3.068	8	4.000	4-1/16
3-1/2	9.25	9.11	.226	4.000	3.548	8	4.625	4-3/16
4	11.00	10.79	.237	4.500	4.026	8	5.200	4-5/16
5	15.00	14.62	.258	5.563	5.047	8	6.296	4-1/2
6	19.45	18.97	.280	6.625	6.065	8	7.390	4-11/16
6-5/8 OD	20.00	19.49	.288	6.625	6.049	8 R	7.390	7-1/4
7 OD	23.00	22.63	.317	7.000	6.366	8 R	7.657	7-1/4
8	25.55	24.70	.277	8.625	8.071	8	9.625	5-1/16
10	35.75	34.25	.307	10.750	10.136	8	11.750	5-9/16
12	45.45	43.77	.330	12.750	12.090	8	14.000	5-15/16
14 OD	57.00	54.57	.375	14.000	13.250	8	15.000	6-3/8
16 OD	65.30	62.58	.375	16.000	15.250	8	17.000	6-3/4
18 OD	73.00	70.59	.375	18.000	17.250	8	19.000	7-1/8
20 OD	81.00	78.60	.375	20.000	19.250	8	21.000	7-5/8

R = Round Threads

(b) *Assembly.* Well casing pipe shall be assembled watertight by means of joints welded in accordance with the standard welding procedure specifications of the department of industry, labor and human relations, Ind 53.53 (3), Wisconsin Administrative Code or by correctly mated, recessed type couplings as used on drill pipe, line pipe or reamed and drifted pipe and having weights and being threaded as indicated in table 2.

(c) *Pipe installation.* Well casing pipe shall be driven or installed so that no injury to the pipe results which may affect the quality of the water supply.

(d) *Pipe specifications.* 1. No used pipe shall be installed as protective well casing in the permanent construction of a well. The pipe used as the permanent protective well casing either in initial well construction or as a liner subsequent to the initial construction shall be new pipe produced to and meeting ASTM A-53; ASTM A-106; ASTM A-120; API 5A; API 5AX; API 5L; API 5LX; standards.

2. Each length of pipe 2 inches in diameter and larger shall be legibly marked in accordance with the ASTM or API marking specifications for the particular pipe standard showing the manufacturer's name or trade mark; size in inches; weight in pounds per foot; whether seamless or welded and, if welded, type of weld; and the ASTM or API specification and grade monogram.

3. The above listed ASTM and API references are available for inspection at the offices of the department of natural resources, the secretary of state and the revisor of statutes and may be obtained for personal use from the American Society for Testing and Materials, 1916 Race Street, Philadelphia, Pennsylvania 19103 and from the American Petroleum Institute, Division of Production, 300 Conigan Tower Bldg., Dallas, Texas 75201.

(e) *Bit sizes.* 1. Cable-tool drilling. Cable tool bits shall have a size no smaller than $\frac{1}{8}$ inch less than the nominal diameter of the drillhole to be constructed at the beginning of construction of a new rock hole or at the beginning of deepening of any existing rock hole. The bits shall be kept dressed.

2. Rotary drilling. a. Cone bits. Cone bits shall have a minimum size not less than $\frac{1}{8}$ inch smaller than the nominal diameter of the drillhole to be constructed.

b. Hammer bits. Hammer bits shall have a size no smaller than $\frac{1}{8}$ inch less than the nominal diameter of the drillhole to be constructed at the beginning of drilling of a new rock hole or at the beginning of deepening of any existing rock hole.

(f) *Liner pipe for caving zones.* Liner pipe installed during or subsequent to the initial well construction to seal off a caving zone in a well shall be new, unused and non-reclaimed pipe but may have a lesser thickness than shown in table 2 for the nominal diameter of pipe used and may have the largest practical diameter permitting installation in the well.

(g) *Rotary-air drilling.* When constructing wells with combination rotary and cable-tool equipment, the respective drilling methods shall comply with the requirements for rotary-air drilling and for cable-tool drilling.

(h) *Water used in drilling.* Water needed in the construction of drillholes shall be clear water obtained from an uncontaminated source. Such water should be disinfected with chlorine so as to reduce to a minimum the time and effort involved in the required final disinfection of the well. (**Note:** See NR 112.15(3) (a).)

(i) *Drilling delays following grouting.* Following placement of grout in the annular space between a protective well casing pipe and upper enlarged drillhole or between a protective liner pipe and lower drillhole and protective well casing pipe, drilling shall be delayed for a minimum of 24 hours, whether using either cable-tool or rotary equipment.

(3) **FLOWING WELLS.** The construction of flowing wells shall comply with the minimum requirements of NR 112.08(2) and the following special conditions:

(a) Every practicable effort shall be made to extend the watertight (cased and cement grouted) construction into the upper confining bed of the artesian basin.

(b) When it is impractical to extend the watertight construction in accordance with paragraph (a), an adequate packer shall be set and

maintained in the confining bed with a flowpipe extending therefrom to a point at least one foot above the established grade.

(c) The driller shall temporarily install an approved well seal with overflow pipe extending therefrom, if necessary, in which case a control valve shall be installed in the overflow pipe and the flow therefrom either limited or stopped. (Note: See figure 1.)

History: Cr. Register, June, 1975, No. 234, eff. 10-1-75; am. table 1, Register, March, 1977, No. 255, eff. 4-1-77.

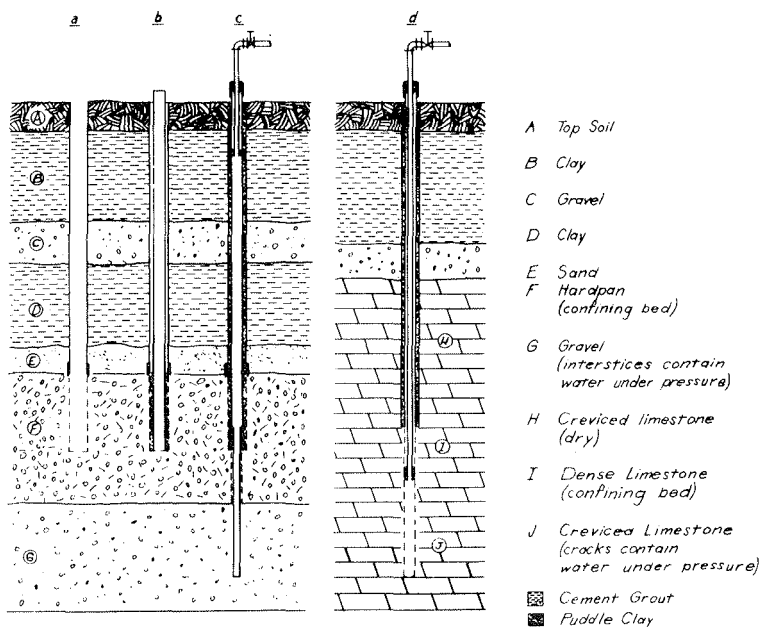

Figure 1. Principle of Construction and Control of Flowing Wells.

NR 112.09 Bored type well design and construction. (1) **GENERAL.** The general construction requirements are the same as NR 112.08(1).

(2) **SPECIFIC.** Through the vertical zone of contamination the construction of bored type wells shall conform to the specifications for drilled type wells prescribed by NR 112.08(2). They shall also conform to the following additional requirements:

(a) The minimum diameter of the casing pipe shall be 6 inches.

(b) The top of the well casing pipe shall terminate at least 8 inches above the ground grade.

(c) The curbing below the vertical zone of contamination shall be properly cured concrete pipe or equal. In such case the joints shall be the tongue and groove type. Plain end or bell and spigot pipe shall not be used.

(d) The minimum inside diameter of well curbing shall be 8 inches.

(Note: The vertical zone of contamination is the same as for a drilled sand or sand and gravel type well. See table 1, NR 112.08 (2) and figure 2.)

History: Cr. Register, June, 1975, No. 234, eff. 10-1-75.

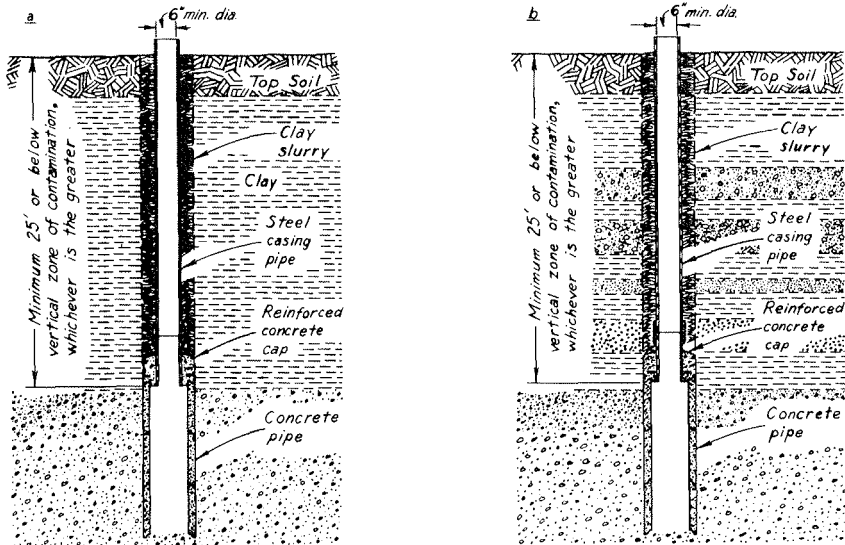

Figure 2. Bored Type Well Construction. See NR 112.09.

NR 112.10 Driven point type well design and construction. (1) GENERAL. The general construction requirements are the same as NR 112.08 (1).

(2) SPECIFIC. Through the vertical zone of contamination the depth of the unperforated pipe of a driven point well shall conform to the specifications of NR 112.08 (2) for drilled sand or sand and gravel type wells. Driven point wells shall also conform to the following additional requirements:

(a) The diameter of the driven point well shall be selected with the expected depth of ground water in mind so as to make a pump installation practical.

(b) The depth of a driven point well shall be sufficient to prevent breaking suction when pumping the well at a rate of 50% greater than the capacity of the permanent pump.

(Note: See figure 3.)

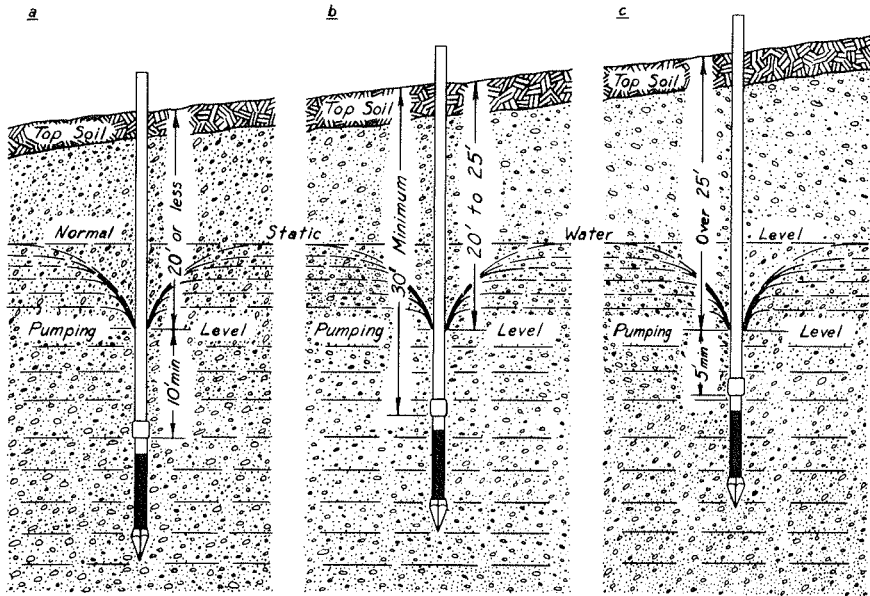

Recommended minimum pipe diameter 2 inches

Figure 3. Construction of Driven-Point Wells in Sand and Gravel. See Table 1. a and NR 112.10.

(c) Protection against freezing shall be accomplished by means of an enclosing casing pipe. So-called "frost-pits" curbed with stones, brick, tile, wood and the like are prohibited. (Note: See figure 4.)

History: Cr. Register, June, 1975, No. 234, eff. 10-1-75.

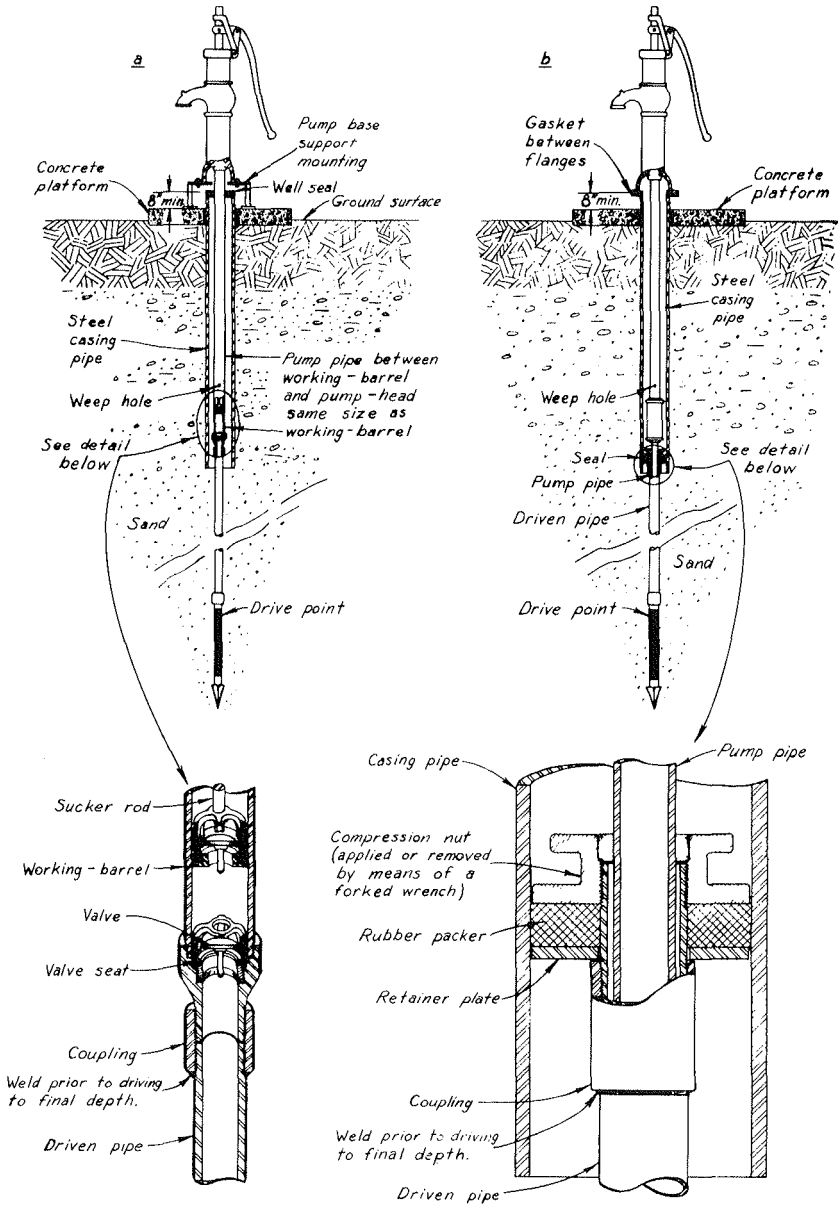

Figure 4. Driven-Point Well Construction. Illustration (b) shows suitable method of returning frost drain water to well when impervious soil is present. See NR 112.10

NR 112.11 Dug type well design and construction. (1) **GENERAL.** The general construction requirements are the same as NR 112.08 (1). ✓

(2) **SPECIFIC.** (a) *Curbing wall.* The curbing wall of every dug type well shall be substantial and watertight to a depth of at least 2 feet below the vertical zone of contamination, which zone is the same as for a drilled sand or sand and gravel type well, but in no case less than 25 feet below the established ground surface at the well. The curbing through the intake area shall be of adequate strength to withstand any external pressure to which it may be subjected and must be seated firmly enough to prevent settling.

(b) *Concrete wall.* The wall shall be circular and at least 6 inches thick with concrete so placed as to be free from voids. The concrete mixture shall conform with the provisions of NR 112.19 (1). Vertical and horizontal reinforcing with $\frac{3}{8}$ -inch rods on 12-inch centers shall be provided. Rods shall lap 12 inches but such lap shall not occur at construction joints. If possible, the wall shall be poured in one operation but in no case shall there be a construction joint within 10 feet of the surface. Construction joints shall be left rough and shall be washed and brushed with neat cement grout before pouring of concrete is continued. (Note: See figures 5 (a) and (b).)

(c) *Metal wall.* A metal curbing wall of steel shall be at least three-sixteenths of an inch thick, assembled with welded joints and in any case, the wall shall be sufficiently thick and so reinforced as to resist any external pressure to which it may be subjected.

(d) *Casing pipe reduction.* In lieu of extending well curbing of full dug well diameter to the surface, a standard weight new steel pipe at least 6 inches in diameter and meeting the requirements of table 2 and NR 112.08 (2) (d) may be used. This pipe shall be firmly seated in a reinforced concrete slab which shall be mounted on the full diameter curbing. Such slab shall be located so that the top is at least 25 feet below the established ground surface at the well or at least 2 feet below the vertical zone of contamination, whichever is the greater. (Note: See figures 5 (c) and (d).)

(e) *Curbing installation.* In caving soil formation, the curbing shall be constructed at the surface and carried down by excavating from the interior. If wood forms are used on the exterior of the wall, they shall be removed before the wall is lowered. Use of exterior wood forms below the ground surface is prohibited. Metal forms may be left in place.

(f) *Annular opening.* The opening between the face of the excavation and curbing or casing through the vertical zone of contamination shall be filled with clean clay slurry or equal.

(g) *Upper terminal.* Except when a dug well is constructed in accordance with paragraph (d) of this subsection and approval has been obtained from the department in conformance with NR 112.14 for construction of a well pit or subsurface pump room adjoining a building basement, the curbing shall be extended at least 8 inches above the established ground surface, and the ground graded up around same to a height of 6 inches above the ground so as to conduct all surface water away from the well.

(h) *Dug well cover.* The cover of a well curbed according to paragraph (b) or (c) of this subsection shall be made of substantial reinforced watertight concrete at least 5 inches thick and of sufficient diameter to overlap the wall or curb by at least 2 inches. The cover shall be free from joints. A pump installation access sleeve comprising a section of steel protective well casing pipe conforming to NR 112.08(2) (a) and (d) shall be installed in the cover at the time of pouring the concrete in fabricating the cover and shall terminate at least 8 inches above the top of the cover. The top of the cover shall be sloped to drain away from the access sleeve. A manhole, if installed, shall be provided with a 4-inch high metal curb which shall be equipped with an overlapping cover, the sides of which extend downward at least 1½ inches. A tight joint shall be provided between the top of the wall and the cover, using a plastic sealing compound. The manhole cover shall be locked or bolted in place in such manner as to be safe and to prevent entrance of water. (Note: See NR 112.17(1).)

(i) *Equipment location.* No pumping equipment or appurtenances requiring access to the interior of the well for maintenance or repair operations shall be installed in the well. (Note: For acceptable type of pump installations, see figure 5.)

History: Cr. Register, June, 1975, No. 234, eff. 10-1-75.

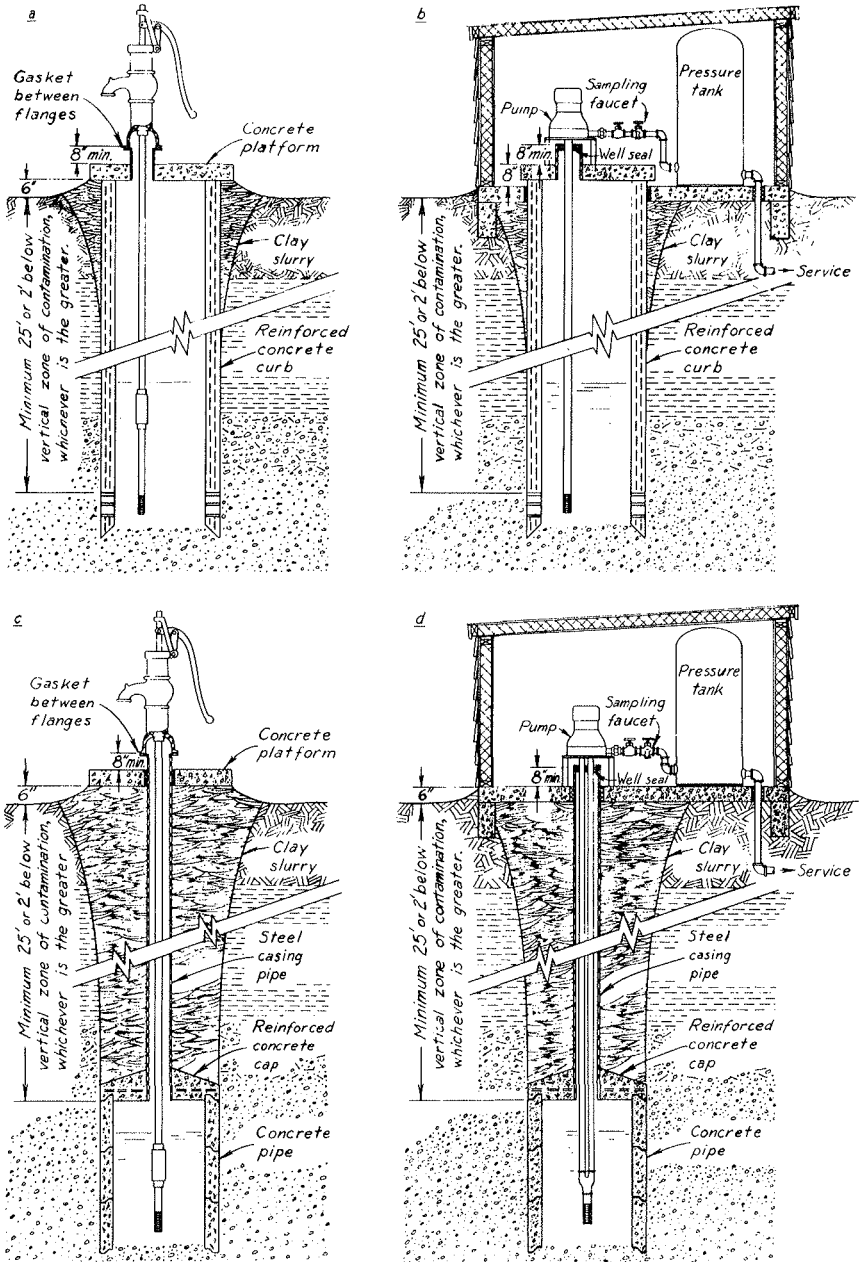

Figure 5. Sanitary Construction of Dug Type Wells and Acceptable Methods of Installation of Pumps. See NR 112.11.

NR 112.12 Reconstructing dug type wells. (1) **GENERAL.** The general construction requirements are the same as NR 112.08 (1).

(2) **SPECIFIC.** A drilled type well may be constructed through an existing dug type well in accordance with the following procedures:

(a) *Preparation for deepening.* Any sediment or debris in the bottom of the dug well shall be removed. The bottom shall be disinfected by distributing a chlorine solution over the bottom or mixing such solution with water in the well. A concentration of 200 parts per million of chlorine should be attained for disinfection.

(b) *Applicability to drilled type construction.* Deepening construction done by drilling methods shall conform to applicable provisions of NR 112.08 (2). (Note: See figure 6.)

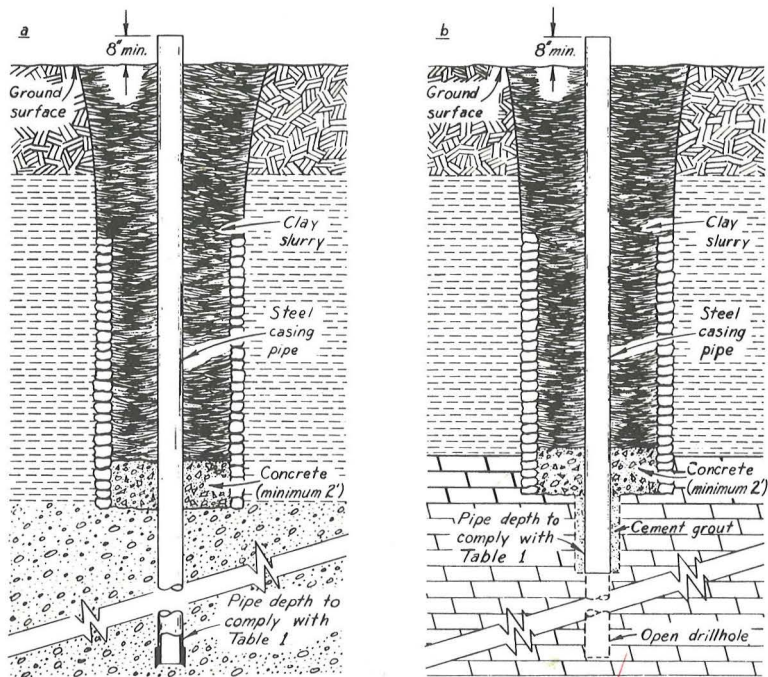

Figure 6. Drilled Well Constructed in Existing Dug Type Well. See NR 112.12.

(c) *Protection.* Existing “dug and drilled” type wells shall be effectively protected against entrance of surface and near-surface water by extending the casing pipe of the drilled part of the well to an elevation of at least 8 inches above the established ground surface and filling the dug part of the well with clay slurry or equally impermeable material, removing the top 7 to 8 feet of curbing in the process to effect a good soil to soil bond.

History: Cr. Register, June, 1975, No. 234, eff. 10-1-75.

Register, June, 1975, No. 234
Environmental Protection

NR 112.13 Springs. Because of the great variation in springs from the standpoint of sources, locations, surrounding land uses, and elevations in relation to surrounding areas, each spring being considered as a possible source of drinking water must be evaluated on its own merits for possible acceptance. Requests for spring evaluations shall be made to the central office of the department. Evaluations shall be based on the following criteria:

(1) **LOCATION.** (a) The area laterally from the spring for a distance of at least 50 feet, below the spring for a distance of at least 30 feet and above the spring to the crest of the slope shall not be used as pasture, crop land or for human habitation.

(b) The spring outlet shall be located at least 2 feet above the regional flood water level.

(c) The spring shall be derived from a source having sufficient overburden so that if a drilled well were constructed at a distance of 100 feet horizontally and upgrade from the spring to produce water from the spring source, the well construction could comply with the minimum well casing pipe depth specifications of table 1, NR 112.08 (2) of this chapter.

(2) **CONSTRUCTION.** To be acceptable as a source of water for drinking and food processing, in addition to meeting the above criteria, a spring shall be protected by the following minimum construction:

(a) Provisions shall be made to divert surface water runoff away from the spring.

(b) A reinforced poured concrete box structure having the following minimum features shall be constructed to house the spring outlet:

1. Five-inch thick walls.
2. Five-inch thick roof.
3. Twenty-four square feet cross-section, with a minimum width of 4 feet.
4. Twenty-inch diameter or 20-inch square access opening in the roof with a 4-inch thick curbing wall extending 8 inches above the roof.
5. Overlapping, tight-fitting, shoebox-type cover with 4-inch skirted sides, constructed out of welded sheet steel.
6. Two 6-inch diameter, steel-pipe sleeves in the roof, having minimum diameters of 4 inches and extending at least 8 inches above the roof for entrance of pump suction pipe and either a pump discharge pipe or a service pipe from a pressure tank.
7. Steel overflow pipe.
8. Discharge pipe from pump or supply pipe from pressure tank extending through the roof and down into the spring, from which point the discharge pipe or supply pipe shall extend below grade to buildings served.
9. Approved type sanitary well seals to seal openings between pipe sleeves and suction pipe and pump discharge or tank service pipe.

(c) An insulated housing shall be provided above the spring box for frost protection for the pump and for the pressure tank, when installed at the spring. (Note: See figure 7.)

History: Cr. Register, June, 1975, No. 234, eff. 10-1-75.

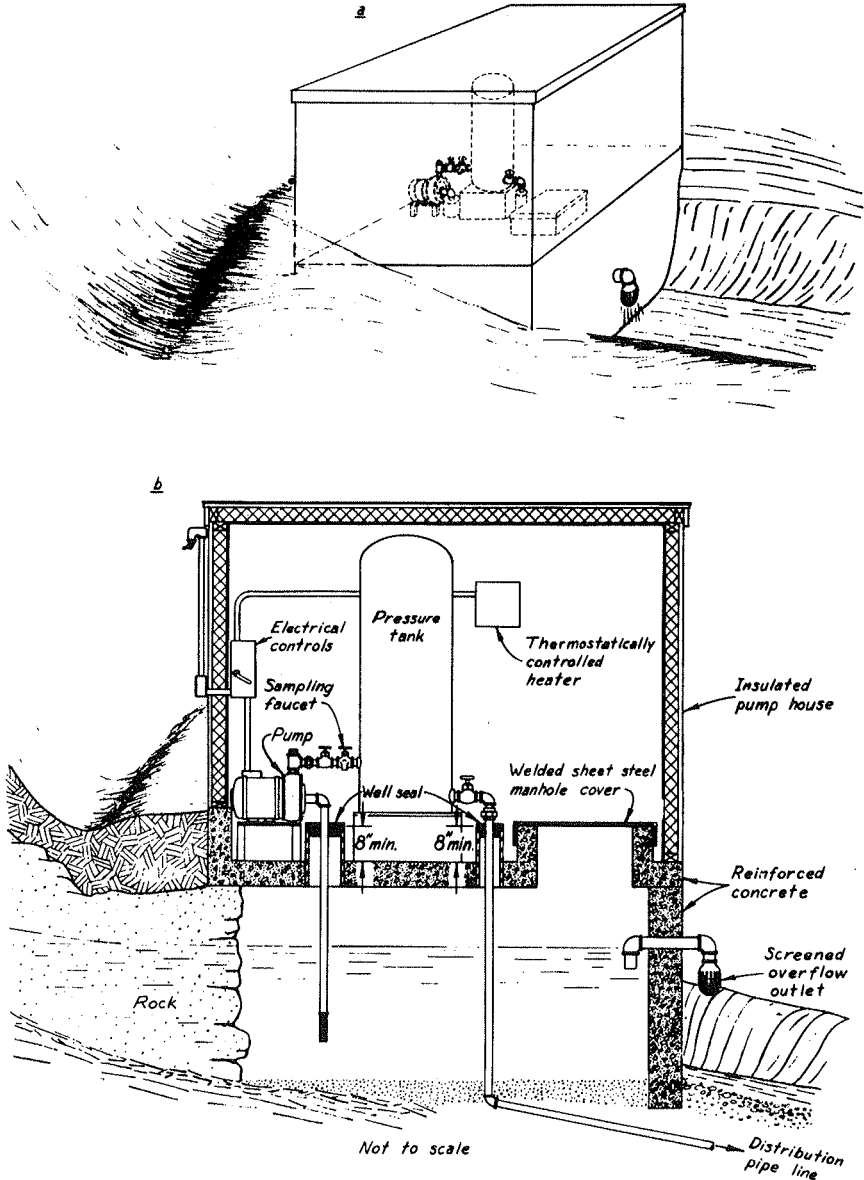

Figure 7. Spring House.

NR 112.14 Surface protection. (1) **WATER SUPPLIES EXCEPT THOSE FOR LESS THAN 4 FAMILIES.** All wells governed by this chapter, except those serving residential units housing a total of not more than 3 families, shall be provided surface protection in accordance with the provisions of this subsection.

(a) The watertight protective well casing pipe shall extend to a point at least 8 inches above the established ground surface unless a permit for construction of a separate well pit or a subsurface pumphoom adjoining a basement has been obtained from the department; except that, within a flood plain, the top of a well shall terminate at least 2 feet above the regional flood elevation and no pit or subsurface pumphoom shall be constructed. (Note: See section NR 112.07 (4).)

(b) Any pitless subsurface pipe connection to such a well shall be made with approved threaded fittings and shall be made above ground water level. The piping for such a connection shall be kept under gauge pressure. For the purpose of this chapter, approved threaded fittings include pitless adapters and pitless receiver tanks designed to be connected to the well casing pipe and approved by the department. The design criteria on which approvals are based involve materials of construction, wall thickness of pipe, wall thickness of other component parts, dimension of shortest cross-section of welds, method of fabrication and method of connection to the well casing.

(c) On off-set installations in basements, the pump impeller or cylinder shall be located preferably at an elevation above the ground surface or at least at an elevation not subject to flooding and in any case at least 2 feet above the basement floor. Pressure conduits may terminate at the end of the horizontal line entering a basement if the elevation of the pipe entrance is 2 feet or more above the basement floor and the basement is in active use and not subject to flooding. Pressure conduit shall meet the minimum pipe specifications of NR 112.08 (2) (a) and (d) for the diameter used.

(2) **WATER SUPPLIES FOR A MAXIMUM TOTAL OF 3 FAMILIES IN RESIDENTIAL UNITS.** Water supplies for residential units housing a total of not more than 3 families, shall be provided surface protection in accordance with the provisions of this subsection.

(a) Watertight protective well casing pipe shall extend to a point at least 8 inches above the established ground surface unless a permit for construction of a separate well pit or sub-surface pumphoom adjoining a basement is obtained from the department, except that, within a flood plain, the top of the well shall terminate at least 2 feet above the regional flood elevation and no pit or subsurface pumphoom may be constructed. (Note: See section NR 112.14 (1).)

(b) Any pitless subsurface connection to such a well shall be made with approved threaded fittings or by means of joints welded in accordance with the standard welding procedure specifications of the department of industry, labor and human relations, Ind 53.53 (3), Wisconsin Administrative Code, and the connection shall be made above ground water level. In addition, the pump location shall not be subject to flooding.

(c) If nonpressure conduit pipe is used to enclose suction, submersible or jet pump piping, it shall be a minimum of new 4-inch diameter or larger diameter steel pipe meeting specifications of Table 2 and NR 112.08(2) (d). Such conduit may terminate in a basement if the elevation of the pipe terminal is at least 2 feet above the basement floor and the basement is in active use and is not subject to flooding.

(d) Restriction on the pipe material when pressurized conduits are used with pitless adapters and the restrictions on the terminal of such pipe in a basement are the same as under NR 112.14(1)√

(3) PITLESS ADAPTERS AND BURIED SUBMERSIBLE PUMP DISCHARGE LINES. Buried submersible pump discharge lines connected to pitless adapters must be maintained under gauge pressure at all times. Therefore, no check valves shall be placed in the pump discharge line between a pitless adapter and a hydropneumatic tank or approved comparable type pressure vessel. The check valve shall be located either at the top of the submersible pump, in that portion of the discharge pipe within the well or on the adapter spool of an approved unit.

(4) PIT PERMITS FOR OTHER THAN WELL PITS. Pit structures for the housing of offset pumps, for access to the head of a buried pressure tank or to completely house a pressure tank shall not be constructed without a permit from the department.

(5) APPLICATION FOR PIT AND SUBSURFACE PUMPROOM PERMITS. Permit applications to construct a well pit, pump pit, pressure-tank pit, pressure-tank access pit or subsurface pumphouse adjoining a building basement, shall be made to the central office of the department on forms provided by the department. Such permits may be granted if the construction will be made in conformance with minimum specifications of the department. (Note: See NR 112.14(1), (2) and (4).)√

(a) Separate well pits, pump pits, pressure-tank pits and pressure-tank access pits shall conform to the following minimum specifications:

1. Dimensions:

a. Area. Five square feet of free floor area shall be provided for each square foot of area required for equipment and appurtenances. In no case shall the inside area of a pit be less than 24-square feet.

b. Width. The width of the pit shall be not less than $\frac{2}{3}$ of the length.

c. Height. The height inside shall be at least 6 feet, but not less than 6 inches higher than any equipment installed therein.

d. Walls, floor and roof thicknesses. The wall thickness shall be at least 6 inches, the floor thickness shall be at least 4 inches and the roof thickness shall be at least 5 inches.

2. Construction:

a. Material. The pit shall be constructed of poured concrete thoroughly puddled in place. The concrete shall be prepared according to specifications of NR 112.19 or by use of clean water and

washed sand and gravel or crushed rock in the following proportions: 1 part cement, 2 parts sand and 3 parts gravel. The water-cement ratio should not exceed 0.75 to 1.

b. Watertight juncture. The junction of walls, floor and roof shall be watertight. Every conduit or similar connection with the pit shall be watertight.

c. Reinforcement. The deck or pit roof and walls of the pit structure shall be adequately reinforced to insure strength and durability.

3. Elevation of pit roof. The pit roof or deck shall be above the ground surface.

4. Manhole opening:

a. Placement. The pit shall be fitted with a manhole opening. It shall be located directly over the well, unless the well casing itself extends through the cover, or a capped section of pipe at least equal in diameter and thickness to the well casing is cast into the pit roof directly over the well.

b. Size. The manhole opening shall be at least 20 inches square or 20 inches in diameter, inside measurement, and in any case shall be sufficiently large to permit entrance or removal of any unit or equipment that must be installed through the manhole.

c. Curbing. The manhole opening shall be provided with a raised curbing at least 4-inches thick, extending at least 4 inches higher than the pit roof.

d. Cover. A substantial watertight, overlapping, tight-fitting, shoe-box type cover with skirted sides at least 3 inches wide shall be provided for the manhole. A welded sheet-steel cover is preferred, but a cover made out of lumber and covered in turn with sheet metal or tin will be acceptable if maintained in a waterproof condition.

e. Exception. A watertight, cast-iron manhole frame and cover with gasket may be substituted for the concrete curbing.

5. Drainage:

a. Gravity Type. Where practical, the pit shall be drained by a separate watertight gravity-type drain discharging to the ground surface at a point free from flooding. The drain shall be constructed of cast iron, copper or galvanized steel having a minimum diameter of 2 inches.

b. Watertight Sump Type. When no gravity-type drain can be installed in conformance with NR 112.14(5) (a) 5a, a watertight sump, having a minimum depth of 18 inches and a minimum cross-section of 18 inches square or minimum diameter of 18 inches, shall be installed.

6. Termination of well casing. In the case of well pits, the casing shall terminate at least 18 inches above the pit floor and be provided with an approved watertight, sanitary well seal with gasket, or an equivalent watertight connection with the pump.

7. Venting:

a. Pit. A well pit, pump pit, pressure-tank pit or pressure-tank access pit shall be vented by use of two 2-inch diameter galvanized steel pipes located in opposite corners, one pipe to extend to within 1 foot of the pit floor and the other to extend only through the pit roof. The upper end of the vent pipes shall terminate with return bends and be screened.

b. Well. Any well vent pipe shall extend to the top of the pit and terminate with a return bend with a screened outlet.

8. Pump Installation. The free space around the well casing shall be such that the upper casing terminal is readily accessible for installation, adjustment or removal of an expanding type or equivalent well seal and for the removal of the pump or piping. The pump powerhead shall be mounted on an elevated subbase of concrete or metal. When pumps are installed with a flanged connection with the casing, all openings in the pump base shall be sealed.

(b) Subsurface pumprooms adjoining basements shall conform to the following minimum specifications:

1. General.

a. The dimensions, construction material, watertight juncture, reinforcement, roof elevation, manhole opening, well casing termination and pump installation shall conform to provisions of NR 112.14(5) (a) 1. through (a) 4. inclusive, NR 112.14(5) (a) 6. and NR 112.14(5) (a) 8.

b. The floor elevation shall be at least 1 foot higher than the basement floor if the basement is constructed with masonry other than reinforced poured concrete.

2. Drainage:

a. The pumproom floor may drain to the basement floor if the basement in turn is adequately drained.

b. If the basement is not adequately drained, a partition wall at least 1 foot high shall be constructed in the entranceway from the basement and separate drainage facilities shall be provided conforming to the pit drainage requirements of NR 112.14(5) (a) 5.

(6) PITLESS ADAPTER WELL AND PIPE CONNECTIONS. (a) *Threaded joints.* When the threaded end of a well casing is not conveniently terminated for installation of a pitless adapter, threads shall be provided at the top of a cut-off well casing for attachment of the pitless adapter, including pitless receiver tanks, by one of the following methods:

1. Cutting threads with a die.

2. Fitting and welding a full-length standard recessed coupling to the top of the casing, after reaming out threads to a point at least $\frac{1}{2}$ the length of the coupling, including the recess, for adapters with male threads.

3. Fitting and welding a full-length standard recessed coupling to the top of the casing, after reaming out threads to a point at least $\frac{1}{2}$ the length of the coupling, including the recess, and installing a steel

pipe nipple made from pipe conforming to NR 112.08(2) and threaded on both ends, for pitless adapters with female threads.

(b) *Weld-on Units.* An approved type pitless adapter weld-on unit may only be installed on wells where nonpressure conduit installations with offset pumps are permissible. These are installations for private residences, serving not more than 3 families. (Note: See NR 112.14(2).) ✓

(c) *Well and pipe connection restrictions.* 1. The threaded lower end of a full-length adapter shall not be welded to the cut-off end of a well casing.

2. The threaded ends of a short model, complete adapter shall not be welded to the top of a cut-off well casing nor to the section of riser pipe extending from the unit to a point above the ground grade.

3. Pitless adapters, including pitless receiver tanks, shall not be connected to the well casing by means of a compressible joint.

4. Pitless adapter pipe connectors for attachment of pump piping shall be welded to the full adapters in the factory at the time the adapter is assembled by the manufacturer having approval to fabricate the same in cases of those designs not involving a casting where the connector will be part of the casting. Such pipe connector units may be welded to the well casing pipe in the field only for those installations where weld-on adapter units are permissible. Pipe connectors shall not be attached to well casings with compression joints. (Note: See NR 112.14(2).) ✓

(d) *Welding Procedure.* The joining of a coupling to the cut-off well casing or of a weld-on pitless adapter unit or pipe connector to a well casing shall be done in accordance with the standard welding procedure specifications of the department of industry, labor and human relations, Ind 53.53(3), ✓ Wisconsin Administrative Code. (Note: For adaption of pitless adapters, including pitless receiver tanks, see Figures 8 and 9.)

History: Cr. Register, June, 1975, No. 234, eff. 10-1-75.

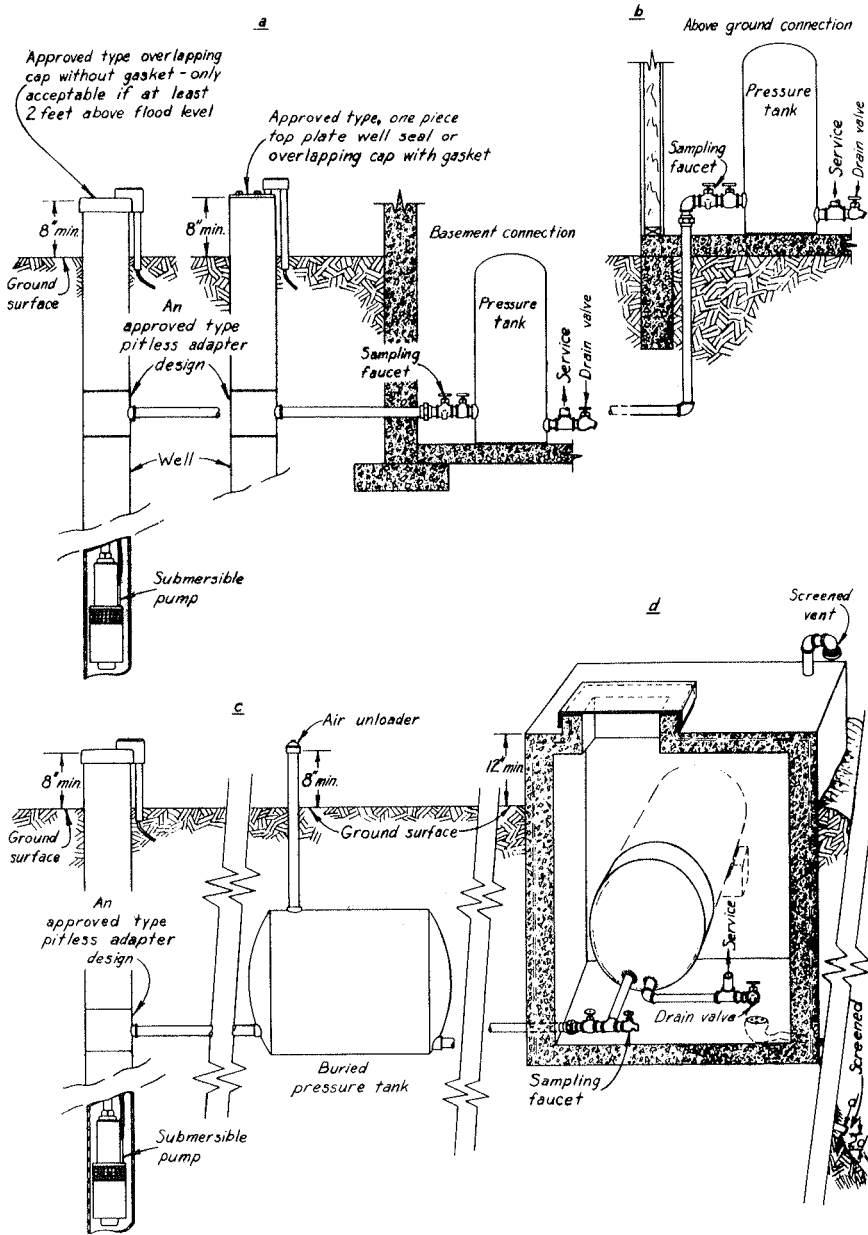

Figure 8. Adaption of Pitless Adapter Unit for Pump Installation.

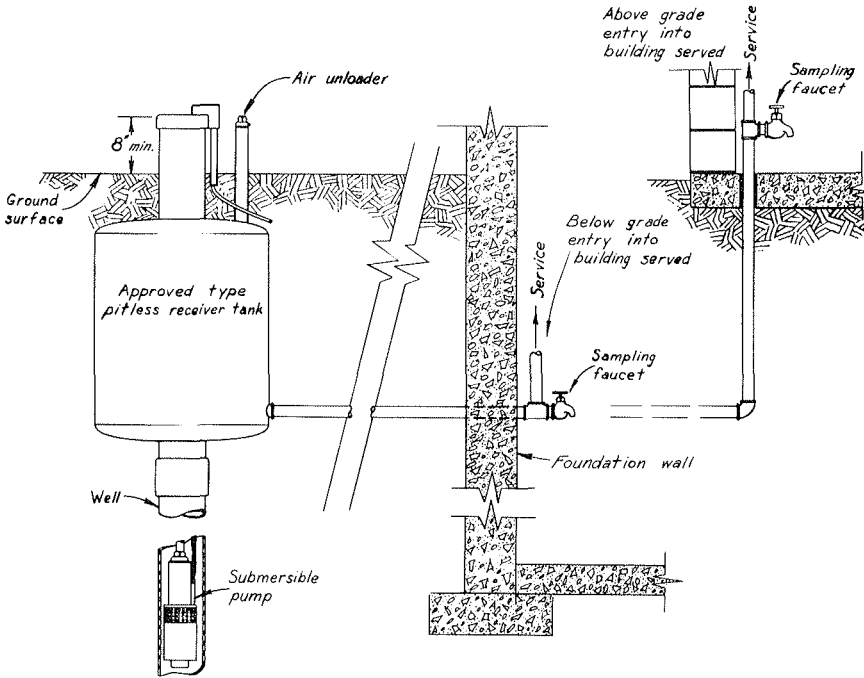

Figure 9. Pitless Receiver Tank Installation.

NR 112.15 Miscellaneous well construction and pump installation requirements. (1) **WELL ALIGNMENT.** The deviation of the center line of a drilled or bored type well from plumb per 100 feet of depth shall not exceed the following tolerances to the depth of pump setting plus 25%:

Diameter of curb in inches	2 to 6	8 to 10	12 or more
Deviation based on diameter.....	100%	75%	50%

For well depths less than 100 feet the allowable deviation of the centerline shall be proportional to that allowed per 100 feet.

(2) **CAVING PROTECTION.** When caving or sloughing formations that would interfere with the proper functioning of the well or the pumping equipment are encountered, entrance of foreign material shall be prevented by means of liner pipe, cementing or other approved methods.

(3) **FINISHING OPERATIONS.** Upon completing well construction or reconstruction operations or pump installation or repair work requiring removal of the pump or pump piping from the well, the well driller and pump installer shall carry out finishing operations as follows:

(a) *Disinfection.* The well shall be disinfected in the manner prescribed by the department. In addition, the pump installer shall disinfect the pump and discharge piping, the pressure vessel or reservoir.

(b) *Flushing.* The well shall be flushed sufficiently to remove all traces of the disinfectant and to condition the well for use. In addition the pump installer shall flush out the discharge piping and the pressure vessel or reservoir.

(c) *Testing.* The well shall be tested by pumping, except when flowing in excess of requirements, to determine the amount of drawdown and the quantity and stability of the yield within the requirements of NR 112.17(1)(b), NR 112.03(2), and NR 112.08(1)(c), or if in excess thereof, as specified by agreement with the purchaser. With flowing wells, the static water level in a stilling pipe or artesian pressure under static conditions shall be measured as shall be the drawdown or reduction in artesian pressure.

(d) *Sealing.* The well shall be sealed or covered with an approved type well seal or well cap. (Note: See NR 112.17(1), NR 112.17(2) and NR 112.17(3).)

(4) **BLASTING.** The use of explosives for increasing or recovering yield of any well developed into limestone, shale, granite or quartzite formations, or of any sandstone well in which casings and liners are not grouted or in which the diameter of the drillhole is larger than that of casings or liners above the point of shooting, shall be undertaken only under permit from the department. (Note: See NR 112.16(3).)

(5) **CHEMICAL CONDITIONING.** (a) *Noncontinuous treatment of wells and pumps.* The use of dry ice, detergents, chlorine, acids, or other chemicals in wells for the purpose of increasing or restoring yield; the use of chemicals, other than chlorine, to combat iron bacteria and sulfur bacteria well infestations and the use of chemicals, other than chlorine, for treatment of pumps for removal of scale or chemical depositions shall be undertaken only under permit from the department. No permit is required for batch chlorination of wells and pumps for disinfection purposes. Chemical treatment of wells requiring a permit shall be done under supervision of a registered well driller or Wisconsin registered professional engineer. Chemical treatment of pumps requiring a permit as established in this subsection shall be done under supervision of a registered pump installer or Wisconsin registered professional engineer. All chemicals other than dry ice or chlorine shall be compounds determined to be acceptable by the department. (Note: See NR 112.16(3).)

(b) *Continuous water treatment of well and water system.* 1. Potability control. Continuous treatment of water in the well or in the water system for disinfection for potability control shall be undertaken only under a permit obtained by the water supply owner

Seals for wells terminating outside of buildings shall have a one-piece top plate. (Note: See NR 112.14(1) and (2).)

(3) **HAND PUMP.** (a) Every shallow well type hand pump and every deep well type hand pump head, shall be so designed and fabricated that no unprotected opening connecting with the interior of the pump exists. The spout shall be of the closed type. (Note: See NR 112.17(4).) ↓

(b) A hand pump shall be connected firmly to the well casing pipe by threading in case of small diameter well pipe or by bolting the pump flange to a well casing pipe flange with gasket separation so as to effectively seal the top of the casing, except that when a well is located so that the top is at least 2 feet above flood level, a hand pump may be installed by bolting a structured base with recesses to the casing. (Note: See figures 4 & 5.)

(4) **POWER DRIVEN PUMP.** (a) Pump setting. 1. Any deep well vertical centrifugal pump shall be so mounted on or over the well casing pipe or on a pump foundation or a pump stand as to permit effective sealing of the top of the well. Any power-driven shallow well suction pump, deep-well piston pump or deep-well jet pump located over the well shall be installed in such manner as to permit installation and removal of an approved type seal at the top of the well, such as an approved type unit with expandable rubber gasket.

2. In case the pump unit is not located over the well, and the shallow well pump suction pipe, submersible pump discharge pipe or jet pump piping emerges from the top thereof, an approved type seal with expandable rubber gasket or approved equivalent seal shall be provided between the well casing and the piping. A similar type seal with expandable rubber gasket shall be provided at the terminal of a nonpressure conduit containing suction, submersible or jet pump piping.

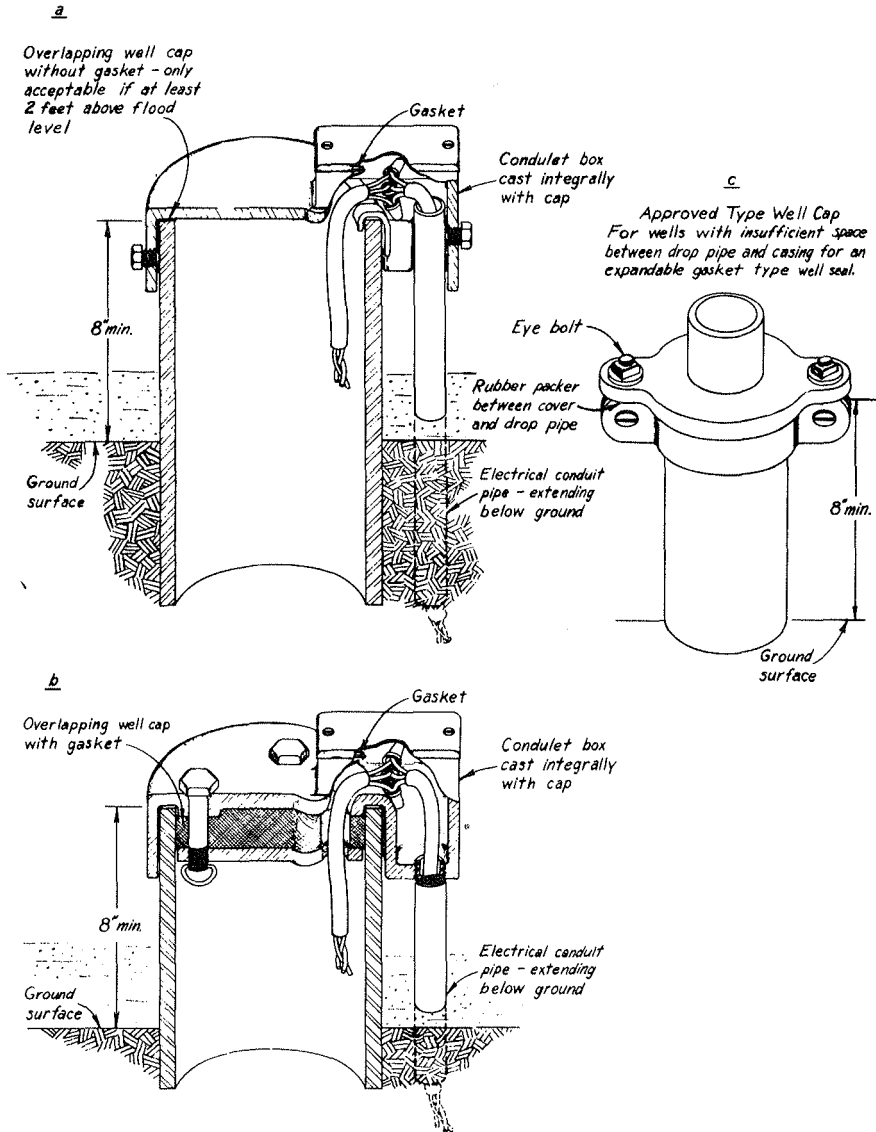

Figure 10. Types of Well Seals. (a) overlapping well cap with skirted sides. (b) and (c) seals using compressible rubber gaskets. See NR 112.17(2) and (4).

from the department. No permit will be granted for continuous disinfection of a well or water system producing bacteriologically unsafe samples until efforts to construct a new well and reconstruct the well or to reconstruct an existing well in conformance with this chapter fail to result in a well that will continuously produce bacteriologically safe water.

2. **Quality control.** Chemical treatment of a well or the total water supply pumped from the well to a point including the pressure tank, reservoir or reservoir and pressure tank when booster pumps are installed, shall be done with chemical compounds and methods approved by the department. Approval of methods of injection of chemicals will be based on adequacy of control of rates of feed against a range of pressures and of the anti-backsiphon provisions of the equipment planned for use.

3. **Equipment installation.** Installation of treatment equipment requiring plumbing connections to the water system shall be made by a licensed plumber, except that when such equipment is installed prior to the pressure tank, the installation may also be made by a registered pump installer.

(6) **OTHER TREATMENT.** Nonchemical type mechanical equipment or devices for continuous water treatment shall be installed in the water system only under permit of the department. All nonchemical treatment of water in the system when permitted by the department shall be done with equipment and methods or processes approved by the department. No permit will be granted for the purpose of continuous nonchemical disinfection of a water supply unless efforts to construct a new well and reconstruct the well or to reconstruct an existing well in conformance with the code have failed to result in a well that will continuously produce bacteriologically safe water. Installation of nonchemical treatment equipment requiring plumbing connections to the water system shall be made by a licensed plumber, except that if such equipment is installed prior to the pressure tank, the installation may also be made by a registered pump installer. Approval of the equipment and method or processes is based on their specific ability to perform effectively over a range of conditions and their having adequate controls, and warning devices when necessary, to prevent accidental supplying of polluted water to points of use.

(7) **DRILLING AIDS.** Materials used as drilling aids such as drilling muds and foam or other aids, shall be compounds or materials approved by the department. Approval of drilling aids is based on toxicity, ground water contaminant possibility and expected effectiveness of the materials.

History: Cr. Register, June, 1975, No. 234, eff. 10-1-75.

NR 112.16 Samples and reports. (1) **WATER SAMPLES.** Upon completion of the well construction, the well driller shall collect a water sample from the well, by use of a pump, for bacteriological analysis. Likewise, upon completion of the installation of pumping equipment and disinfection and flushing of the well and water system, the pump installer shall collect a sample from the well for bacteriological analysis. Exceptions to these procedures will be permitted when the well driller also installs the pump, in which case submission of the required sample upon completion of the pump

installation will be considered satisfactory compliance. Where unforeseeable contamination is encountered, the initial construction of a well will be considered complete if the construction conforms to provisions of this chapter. The water samples shall be submitted either to the state laboratory of hygiene or to an independent laboratory certified under the state laboratory certification program to do bacteriological examination of water; provided that, such certified laboratory will file the water sample data sheet and a copy of the water sample analysis report with the department within 20 days following completion of the analysis.

(2) **WELL CONSTRUCTION REPORTS TO DEPARTMENT.** Within 20 days after completing the construction or reconstruction of a well the constructor thereof shall submit a construction report to the department upon a form prescribed and furnished by the department.

(3) **WELL CONDITIONING REPORT TO DEPARTMENT.** Within 20 days after completing any well blasting or chemical treatment operation the well driller, pump installer or other supervisor shall submit a complete report as to methods used and the results achieved for cases covered by the section. (Note: See NR 112.15(4) and NR 112.15(5) (a).) ↓

(4) **REPORTS TO OWNERS.** The well driller and pump installer shall supply the owner or his agent with a copy of the laboratory analyses report for the sample submitted to the laboratory at completion of their respective work. The well driller shall also supply to the owner or his agent a copy of the well construction report at the time the report is made to the department.

History: Cr. Register, June, 1975, No. 234, eff. 10-1-75.

NR 112.17 Pump installation and construction. (1) **GENERAL.** The installation of every pump shall be so planned and carried out so that the pump will be:

(a) Installed in such manner that the pump and its surroundings can be kept in a sanitary condition.

(b) Properly sized so as to produce the volume of water necessary to meet the requirement of an adequate water supply. (Note: See NR 112.03(2).) ↓

(c) Designed to meet the well characteristics, durable in character and installed in such manner that continued operation without priming is assured at the time of installation.

(d) Installed in such manner as to provide adequate protection against contamination of any character from any surface or subsurface source.

(2) **UPPER WELL TERMINAL.** The casing pipe of any drilled, bored or driven type well or of a dug well having a casing pipe reduction shall project not less than 8 inches above the permanent established ground surface at the well, or 8 inches above a pump house or building floor or platform installed above such established ground surface unless a permit for a subsurface terminal has been obtained. The well casing pipe shall be sealed or covered with an approved type well seal or cap, except that a nonwatertight cap shall not be used in pit installations.

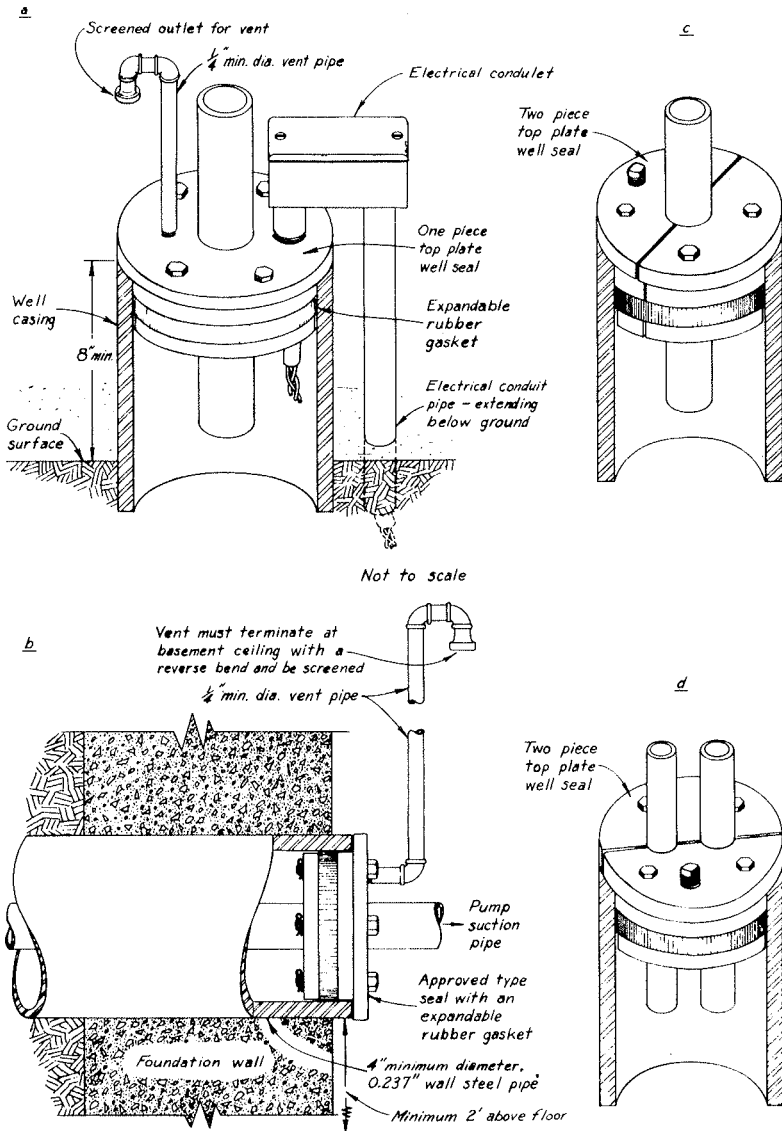

Figure 11. Types of Well Seals. (a) top of well seal using compressible rubber gasket. (c) and (d) also top of well seals with compressible rubber gaskets but with split top and bottom plates and gasket requiring acceptable housing protection. (b) nonpressure conduit seal using compressible rubber gasket. See NR 112.17(2) and (4).

3. On above-ground pump installations the extension of the well casing at least 1 inch above a concrete pump support base and into the pump base will be considered an effective seal if the elevation of the top of the well is at least 2 feet above the regional flood water level at the site and provided the pump base is mounted on a base plate or foundation in such manner as to exclude entrance of insects into the well. (**Note:** See sections NR 112.14(1) and (2) and NR 112.17(8).)

4. If the pump base of a deep well vertical centrifugal pump is not of a recessed type or if the pump support flange for the pump column is of larger diameter than the well casing, the extension of the well casing 1 inch above the bottom of a pump subbase also will be considered an effective seal, subject to the same restrictions as stipulated in subparagraph 3 and provided that:

a. The top of the subbase and the bottom of the pump base are secured together as an integral unit by bolts, and

b. if either the top surface of the subbase or the bottom of the pump base is not a machined surface, a gasket is provided between the 2 surfaces prior to joining them permanently together.

c. The structure housing a power driven pump shall be constructed having the following minimum features:

i. Reinforced poured-concrete floor with top of the floor at least 4 inches above the established grade.

ii. Walk-in door opening outward when the pumphouse is large enough.

iii. Trapped floor drain discharging to the ground surface when a door is not installed.

iv. Thermostatically controlled electrical heating unit.

v. Removable or hinged roof.

vi. Insulated walls and roof.

vii. Walls firmly secured to floor.

viii. Dimensions and actual details of wall and roof design are optional. The dimensions in table 3, figure 12 are recommendations. (**Note:** See section NR 112.14(2) and figures 12 and 13.)

d. Unless an approved-type above-ground discharge unit is installed as illustrated in figures 14 or 15, or the discharge pipe is installed above grade and drains back above grade into the well between pumping cycles, the pump discharge line and accessory equipment installed above grade shall be protected against freezing by insulation of structure and piping and installation of dependable heating facilities, preferably a thermostatically controlled type.

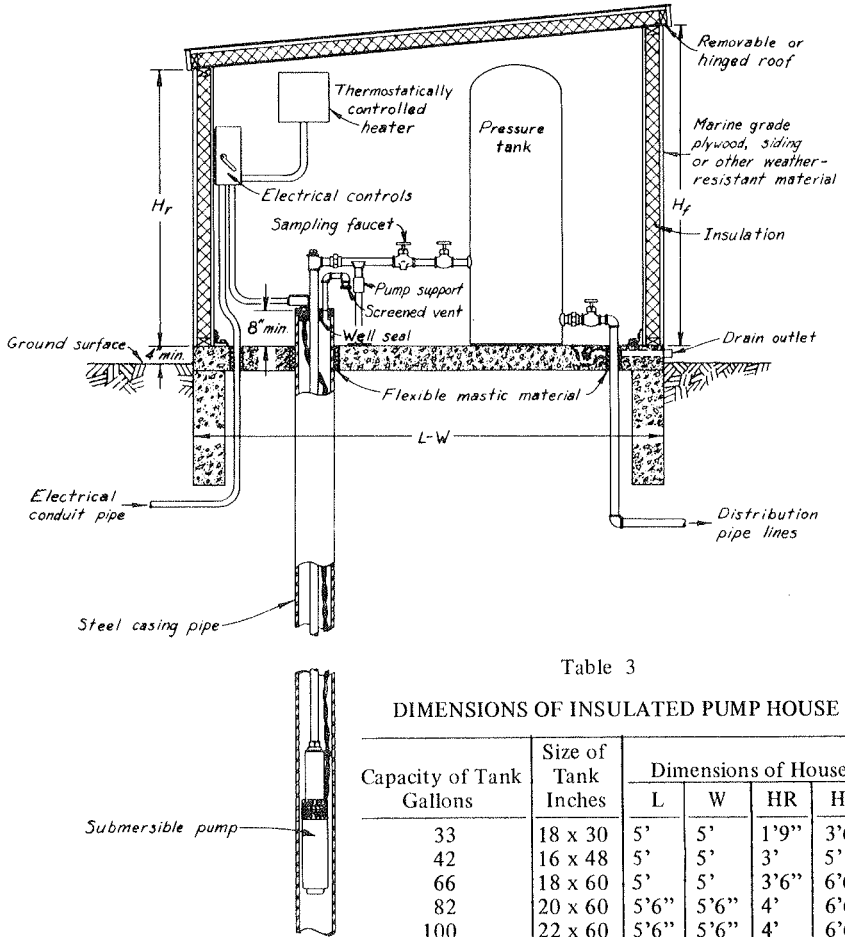

Table 3

DIMENSIONS OF INSULATED PUMP HOUSE

Capacity of Tank Gallons	Size of Tank Inches	Dimensions of House			
		L	W	HR	HF
33	18 x 30	5'	5'	1'9"	3'6"
42	16 x 48	5'	5'	3'	5'
66	18 x 60	5'	5'	3'6"	6'6"
82	20 x 60	5'6"	5'6"	4'	6'6"
100	22 x 60	5'6"	5'6"	4'	6'6"
120	24 x 60	5'6"	5'6"	4'	6'6"
220	30 x 72	6'6"	6'6"	5'	7'6"

Figure 12. Insulated Pumphouse Enclosing Pressure Tank.

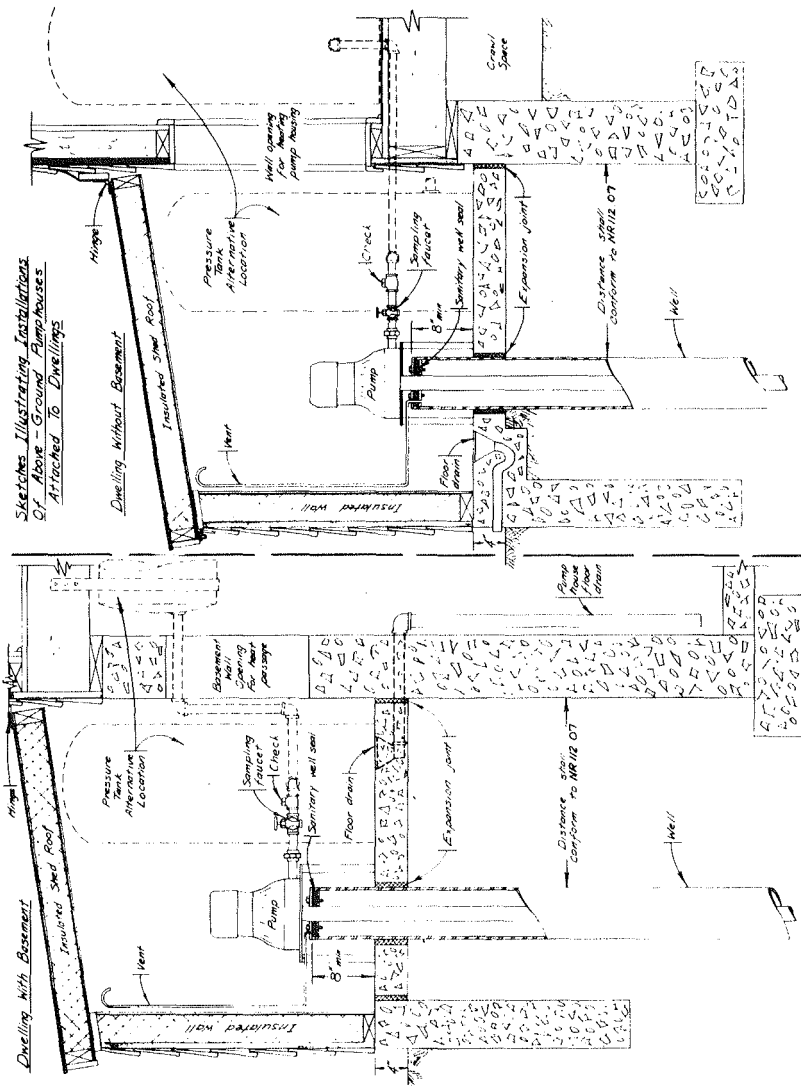

Figure 1.3. Insulated Pumphouse Adjoining a Dwelling.

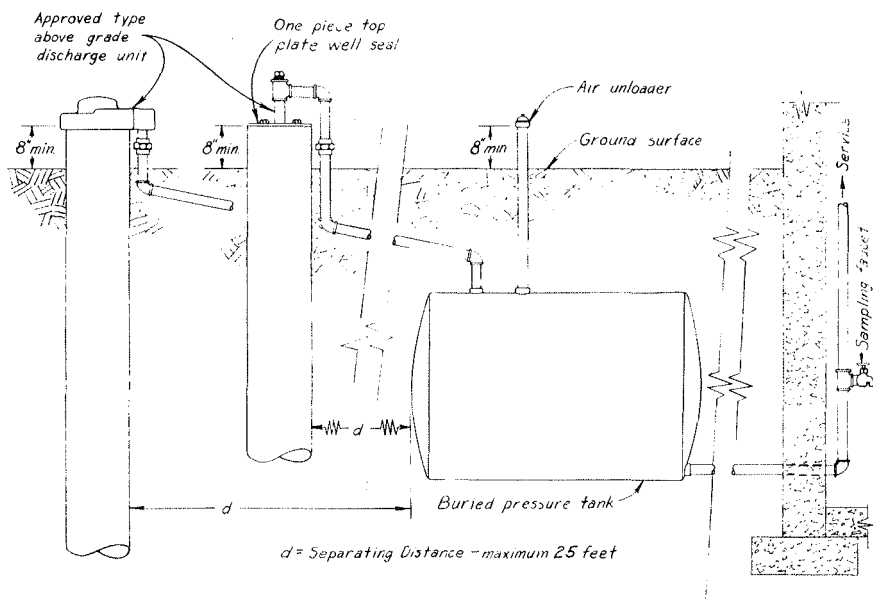

Figure 14. Pump Installations using Submersible Pumps and Approved Above-Ground Discharge Unit.

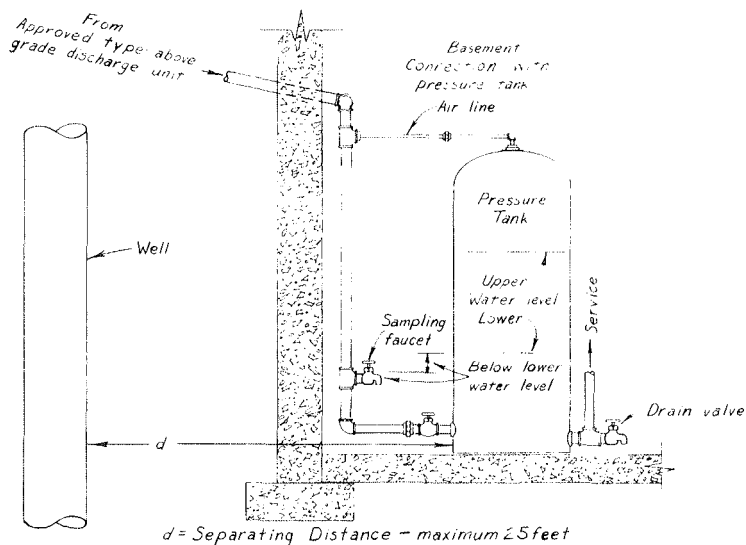

Figure 15. Alternative Pressure Tank Location with Submersible Pump Installation and Approved Above-Ground Discharge Unit.

(5) RESERVOIR CONSTRUCTION. (a) A subsurface ground storage reservoir may be used to store water for drinking and other domestic purposes providing that it is constructed in accordance with the following minimum specifications:

1. Floor. The floor of a reservoir shall be reinforced poured concrete with a thickness of at least 5 inches and a curbing wall 6 inches high and 6 inches thick, having a keyway for a construction joint with the walls. Any pump supply pipe and service pipe planned to extend through the floor, any copper water stop strip for the wall construction joint, and any reservoir drain facility shall be installed during the time of pouring the concrete floor.

2. Walls. The walls of a reservoir shall be reinforced poured concrete at least 6 inches thick. Should it be planned to install the pump supply pipe to the reservoir through a wall and to install the service line pipe in a wall as opposed to installation of the units in the reservoir floor, the pipe fittings for such units shall be installed at the time of pouring the walls so as to effect a watertight joint.

3. Roof. The roof shall be reinforced poured concrete at least 5 inches thick. An access manhole at least 24 inches in diameter or 24 inches square shall be constructed as an integral part of the reservoir roof. The manhole shall have a curbing wall extending at least 12 inches above the earth covering the roof or at least 6 inches higher than the roof, if the roof is not buried. The manhole curbing preferably shall be constructed entirely of 4-inch thick reinforced poured concrete, but may be partially steel or cast iron. The curbing shall be provided with a snug fitting, overlapping cover with a minimum of 3-inch wide skirted sides. The cover preferably shall be constructed with welded sheet steel but may be constructed with reinforced poured concrete.

4. Overflow. An overflow pipe, if used, shall be located just under the roof of the reservoir entirely above grade and terminate with a down-turned pipe at a point at least 12 inches above the ground grade. The pipe shall have a screened outlet. The overflow pipe shall be of sufficient diameter to permit waste of water at a rate in excess of the well pump operating capacity.

5. Vent pipe. A vent pipe shall be installed whenever the roof of the reservoir will terminate below the ground surface or at an inadequate distance above grade to permit installation of an overflow pipe in a reservoir wall just below the roof. The diameter of such vent pipe shall be large enough so that it can act as an overflow pipe to permit waste of water in excess of the well pump operating capacity. It shall be installed in the reservoir roof at the time of construction of the roof and shall be encased with 6 inches of concrete from the top of the roof to the ground surface if the roof is buried. The vent pipe shall terminate with a "U" bend with screened outlet a minimum of one foot above the ground grade or top of the reservoir. (Note: See Figures 16 and 17 for acceptable pump installation with reservoir.)

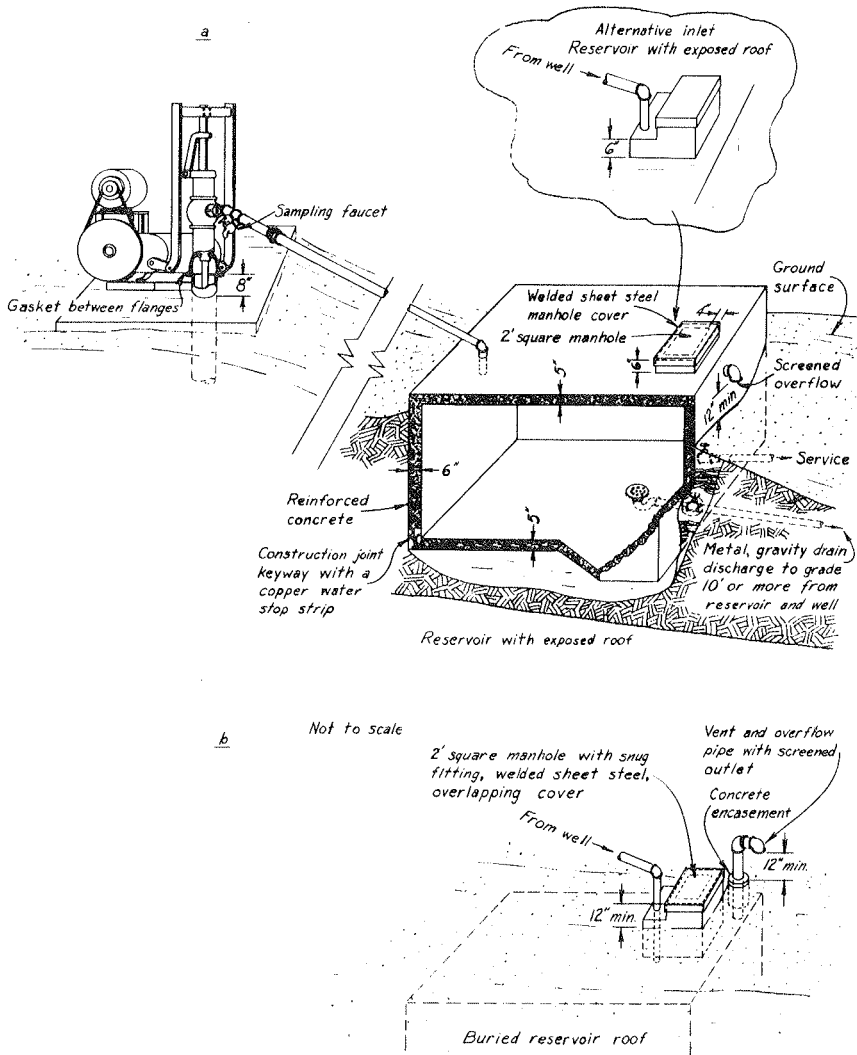

Figure 16. Water Storage Reservoir. (b) shows Acceptable Method of Supplying Water to Reservoir from pump when roof of reservoir is buried.

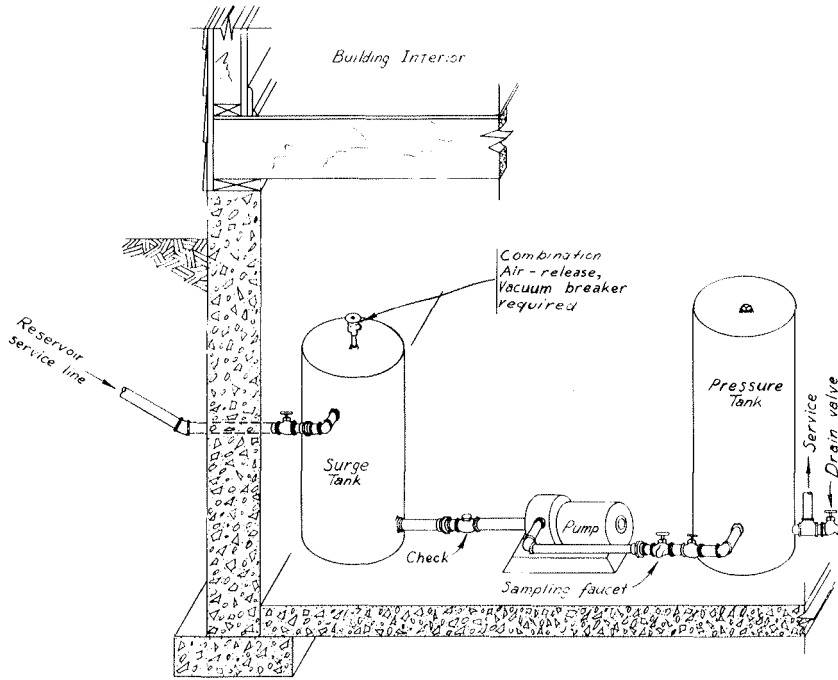

Figure 17. Acceptable Installation of Booster Pump on Service Line from Reservoir, when necessary.

6. Supply pipe. Any gravity supply pipe from a hand type pump shall be assembled with permanent pipe fittings and shall be conducted into the reservoir through the roof or curbing for the manhole, if the roof is not buried, and only through the manhole curbing if the roof is buried. A supply pipe may be connected to the reservoir below grade provided that it will be under no less than 5 feet of head at any time. This will necessitate a pitless adapter installation, either with a submersible or deep well reciprocating type pump. The supply pipe in such case shall terminate at or no more than a few inches above the bottom of the reservoir and a float control switch or low and high water level electrical pump-control rods shall be installed. Any check valve shall be placed only in the portion of the pump discharge pipe located within the well. The supply and service pipe may be combined.

(6) PRESSURE VESSELS: (a) *Steel pressure vessels.* All steel tanks for containing water under pressure for domestic supplies, including those having an air space for expansion, shall meet the following specifications:

1. They shall have a $\frac{1}{4}$ inch minimum side wall and head wall thickness, when the tanks are approved pitless receiver units attached directly to well casings.

2. They shall have a $\frac{3}{16}$ -inch minimum side wall and head wall thickness when the tanks will be buried within 10 feet of wells.

3. They shall be identified by stamping showing the manufacturer's name, a serial number, the allowable working pressure and the year fabricated.

4. No tanks relying on expansion of a rubber cylinder or liner within a restricting metal container rather than on compression of air to provide pressure in the water supply system shall be used unless approved by the department. Approvals are based on strength of container and information indicating either National Sanitation Foundation (NSF) or Food and Drug Administration (FDA) approved products are used.

5. Inner tank surface paints and other coatings shall comply with the American Water Works Association (AWWA) standard D102 and be approved by the department. The AWWA Standard D102 is available for inspection at the offices of the department of natural resources, the secretary of state, and the revisor of statutes and may be obtained for personal use from the American Water Works Association, Inc., 6666 W. Quincey Ave., Denver, Colorado 80235.

6. No floating discs shall be used in tanks to reduce the air-water contact surface unless the disc material is approved by the department. Approvals are based on information indicating either NSF or FDA approved products are used.

(b) *Nonmetal pressure vessels.* No nonmetal tanks for containing water under pressure for domestic supplies, including those having an air space for expansion shall be used unless approved by the department. Approvals are based on strength of container and information indicating either NSF or FDA approved products are used and practicability in making pipe connections.

(Note: For safety requirements for both steel and nonmetal pressure vessels, consult Wis. Adm. Code, chapter Ind. 41, which contains the Boiler & Pressure Vessel Code of the department of industry, labor and human relations.)

(7) **PIPE MATERIALS.** Pump piping shall conform to the State Plumbing Code as set forth in Wis. Adm. Code, chapter H62. Limitations on use of plastic pipe are also found in chapter H62. Similar quality plastic pipe will be acceptable as drop pipe installed entirely within a well below the well seal.

(8) **WELL VENT.** Any well vent pipe shall be installed watertight to a point not less than 24 inches above any known flood water level but at least 6 inches above the top of the well except that in well pits or subsurface pumphrooms or when a vent exists in the well seal at the basement end of a nonpressure conduit the vent pipe shall extend to the ceiling of the structure. Such pipe shall be not less than ¼ inch in diameter and shall be firmly attached to a well seal or base of a deep well vertical centrifugal pump when one is installed. The vent pipe shall be terminated in a reverse bend and be screened so as to prevent entrance of foreign matter. Any opening in a pump base shall be sealed watertight.

(9) **SAMPLING FAUCET.** (a) In all pressure water systems provision shall be made for collection of water samples by installation of a sampling faucet on the discharge side of the pump. Such faucet shall be installed between the pump and a reservoir or between a pump and pressure tank when the tank is not buried, or when the tank position

or the type of pump installation permits this without loss of air from the tank.

(b) In the case of buried pressure tanks, when either an approved type pitless adapter or an approved type above-ground discharge unit, depending on displacement of water in the exposed discharge pipe by air from the tank for frost protection, is installed, a sampling faucet is required in the service line from the tank at a point immediately following the point of entry into the building or building basement.

(c) When an approved above ground discharge unit is used, and the tank is in the basement the sampling faucet must be installed in the service pipe from the tank at an elevation sufficiently above the floor to facilitate obtaining a water sample unless the installation is so made that a sampling faucet can be placed in the discharge line without the problem of permitting loss of air from the system when the faucet is opened. Drain valves for tanks which are often placed in the service line from the tank at a point very near the floor are not acceptable as a sampling faucet.

(10) CASING NOT PART OF PUMP INSTALLATION. In areas where ground water is known to be corrosive, no pipe serving as the casing of any well shall be used as a delivery pipe or be utilized in the pumping operation. Moving pump parts located in any well shall be enclosed.

(11) DISINFECTION AND SAMPLING. Upon completing the installation of pumping equipment, the installer thereof shall disinfect the equipment by disinfecting the well and drawing water into the system by pumping and shall sample water in accordance with NR 112.15 (3) (a) and (b) and NR 112.16(1) and (4).

(12) EMERGENCY PUMP INSTALLATIONS. No pump shall be repaired and reinstalled or newly installed for a well when it is a nonconforming structure except that a pump may be reinstalled or newly installed in such well in an emergency situation provided that the owner is informed in writing of the needed correction or replacement of the well, as the case may be, and a copy of such communication is filed with the department.

(13) PUMP INSTALLATIONS FOR FLOWING WELLS. (a) *Underground pipe connections.* No underground pipe connections shall be made to a flowing well except when an approved type pitless adapter is used.

(b) *Suction lines.* No shallow well type pump shall be connected directly to the pipe connected to a pitless adapter of a flowing well or to a pipe extending out of the seal at the top of the well and redirected back into the ground and over to a building basement. Such piping from the well shall enter a surge tank having either an overflow pipe or a vacuum breaker valve installed in the top of the tank. Any booster pump shall be connected to the surge tank and can discharge into a hydropneumatic tank.

(c) *Overflow piping.* 1. Where possible, once an artesian well is placed in use, the flow from the well to waste shall be stopped.

2. If the well has been constructed in conformance with section NR 112.08(3), a controlled overflow pipe may be installed, if necessary, to prevent physical damage due to escaping water upward outside the

well casing or to prevent a freezing problem from occurring in the top portion of the well.

3. Any overflow to prevent freezing shall be limited to the absolute minimum to preserve ground water and pressure. The overflow pipe may be either installed at the top of the well or on a surge tank. The overflow pipe shall terminate at least 2 pipe diameters above a drain at the well site or in a building or building basement. (**Note:** Illustrations of acceptable pump installations with flowing wells are illustrated in figures 18 through 24.)

History: Cr. Register, June, 1975, No. 234, eff. 10-1-75; am. (4) (a) 4. d. and figures 13, 14 and 15, Register, March, 1977, No. 255, eff. 4-1-77.

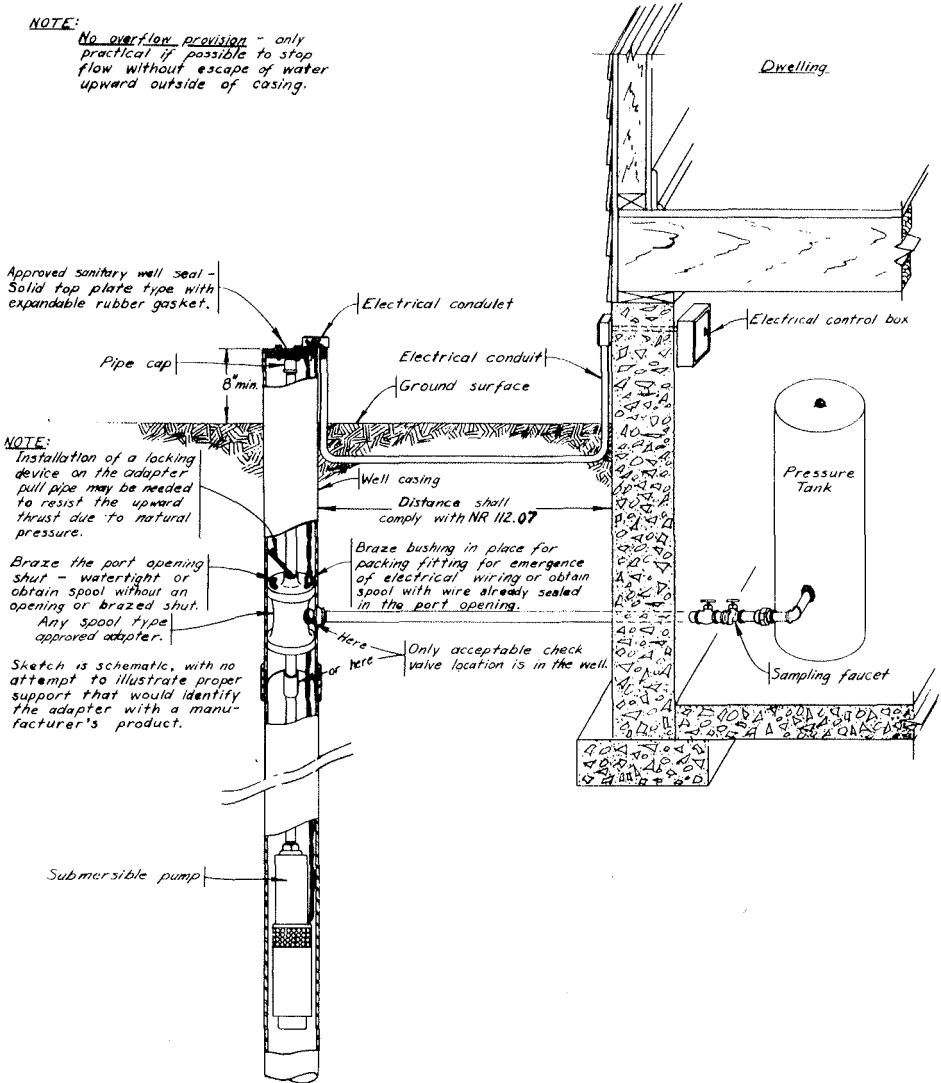

Figure 18. Pump Installation for Flowing Artesian Well using an Approved Pitless Adapter and Submersible Pump with no Overflow Provision.

NOTE:

No overflow provision - only practical if possible to stop flow without escape of water upward outside of casing.

Approved sanitary well seal - Solid top plate type with expandable rubber gasket.

Pipe cap
Ground surface
8 min.

NOTE:

Installation of a locking device on the adapter pull pipe may be needed to resist the upward thrust due to natural pressure.

Braze the port openings shut watertight. Preferably order without cores.

Any spool type approved adapter.

Sketch is schematic, with no attempt to illustrate proper support that would identify the adapter with a manufacturer's product.

Well casing
Distance shall comply with NR 112.07

Plain drop pipe
(No pump in well)

Dwelling

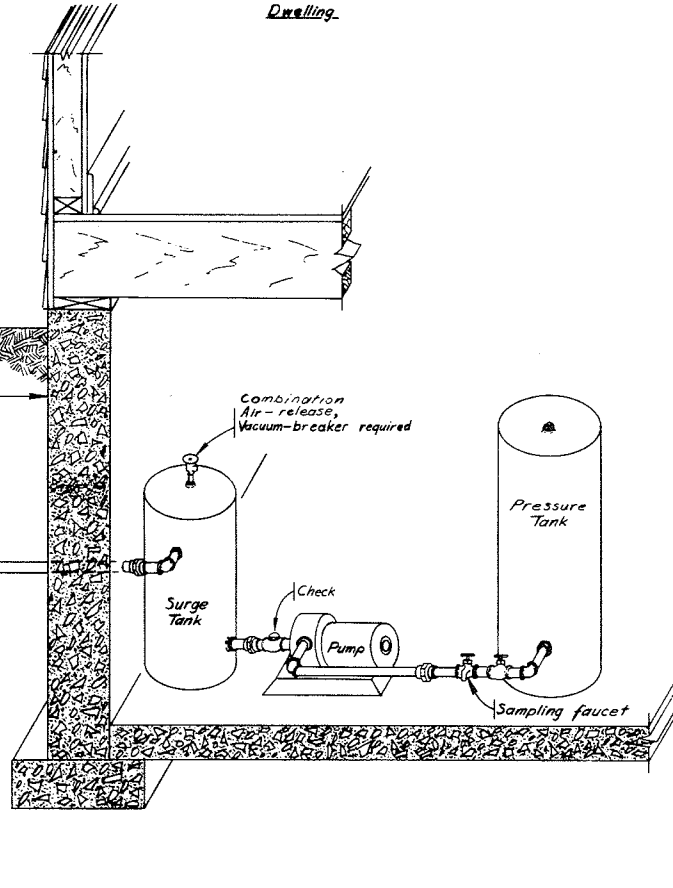

Figure 19. Pump Installation for Flowing Artesian Well using an Approved Pitless Adapter, Surge Tank and Booster Pump with no Overflow Provision.

NOTE:

Overflow pipe shall not be installed unless physical damage will occur due to water escaping upward around casing.

Throttling valve. Throttle to the maximum possible. See note above.

At least 2 pipe dia. free fall

Discharge to grade at least 10ft. from well

NOTE - Cable opening through seal must be sealed watertight.

A shallow well pump may also be used placed in pumphouse

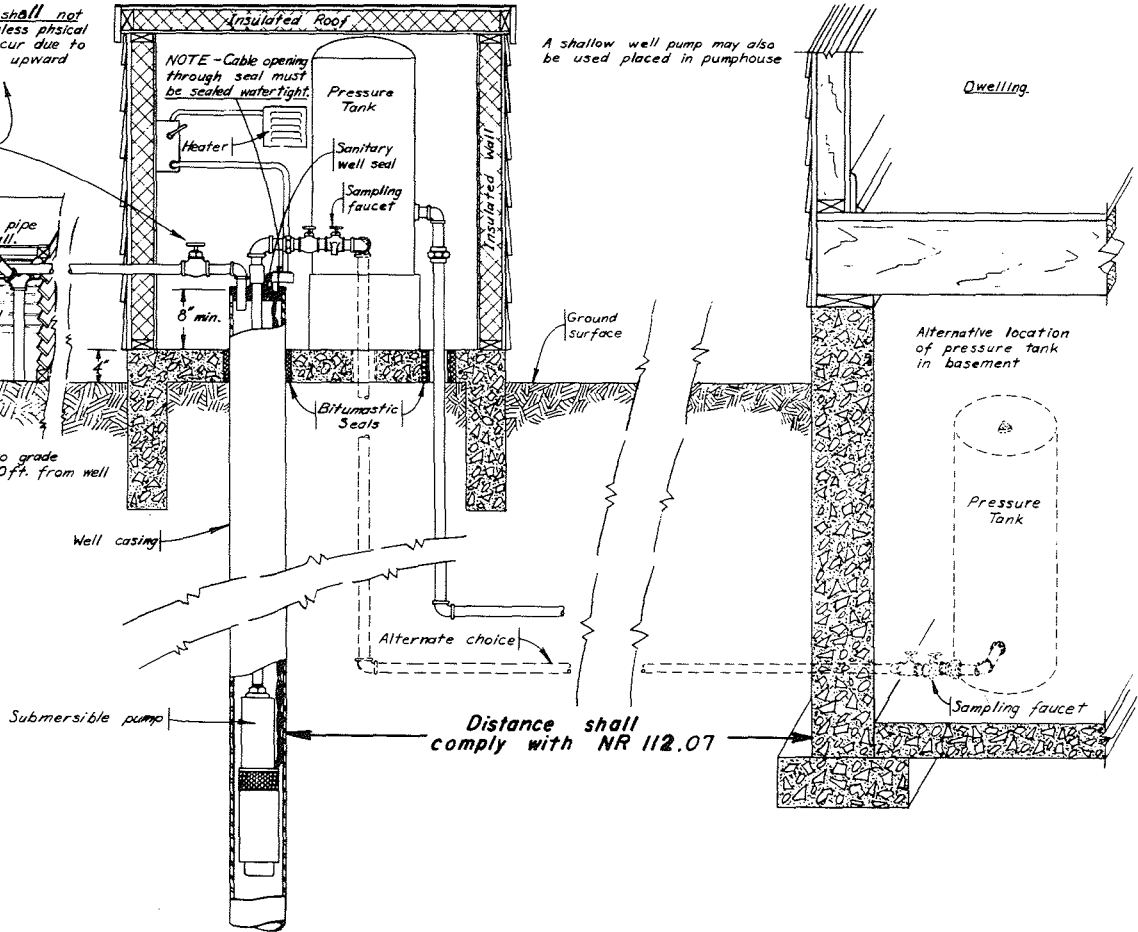

Figure 20. Pump Installation for Flowing Well using Submersible Pump and Above-Ground Discharge and Overflow Provision, if necessary.

NOTE:

Well overflow pipe shall only be installed if physical damage would otherwise occur due to water escaping upward around the casing or to prevent freezing of the top of the well, should it not be desired to construct an insulated structure over the well. However, the insulated structure would be preferred for frost protection, should the overflow pipe not be necessary to prevent physical damage to the well.

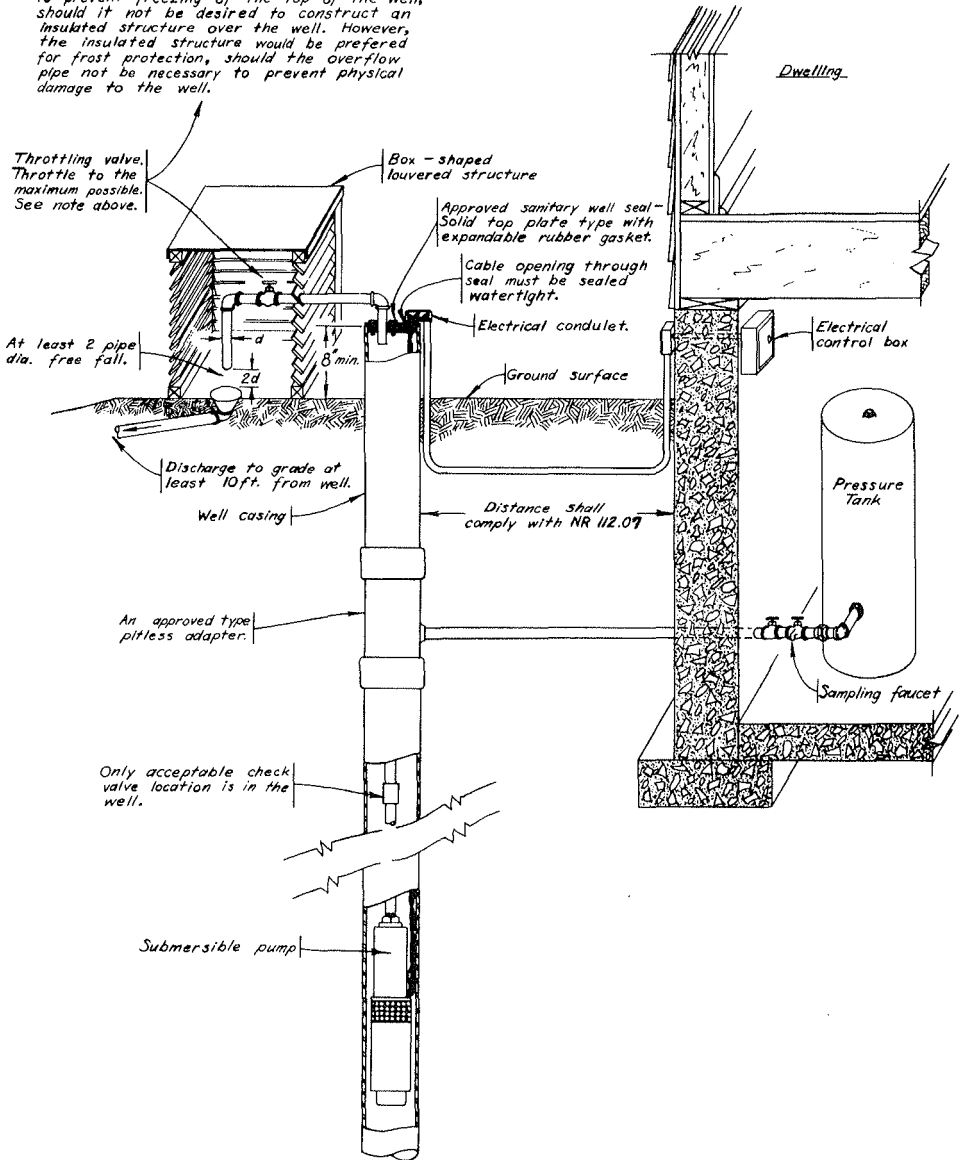

Figure 21. Pump Installation for Flowing Well using an Approved Pitless Adapter and Submersible Pump and Overflow Provision, if necessary.

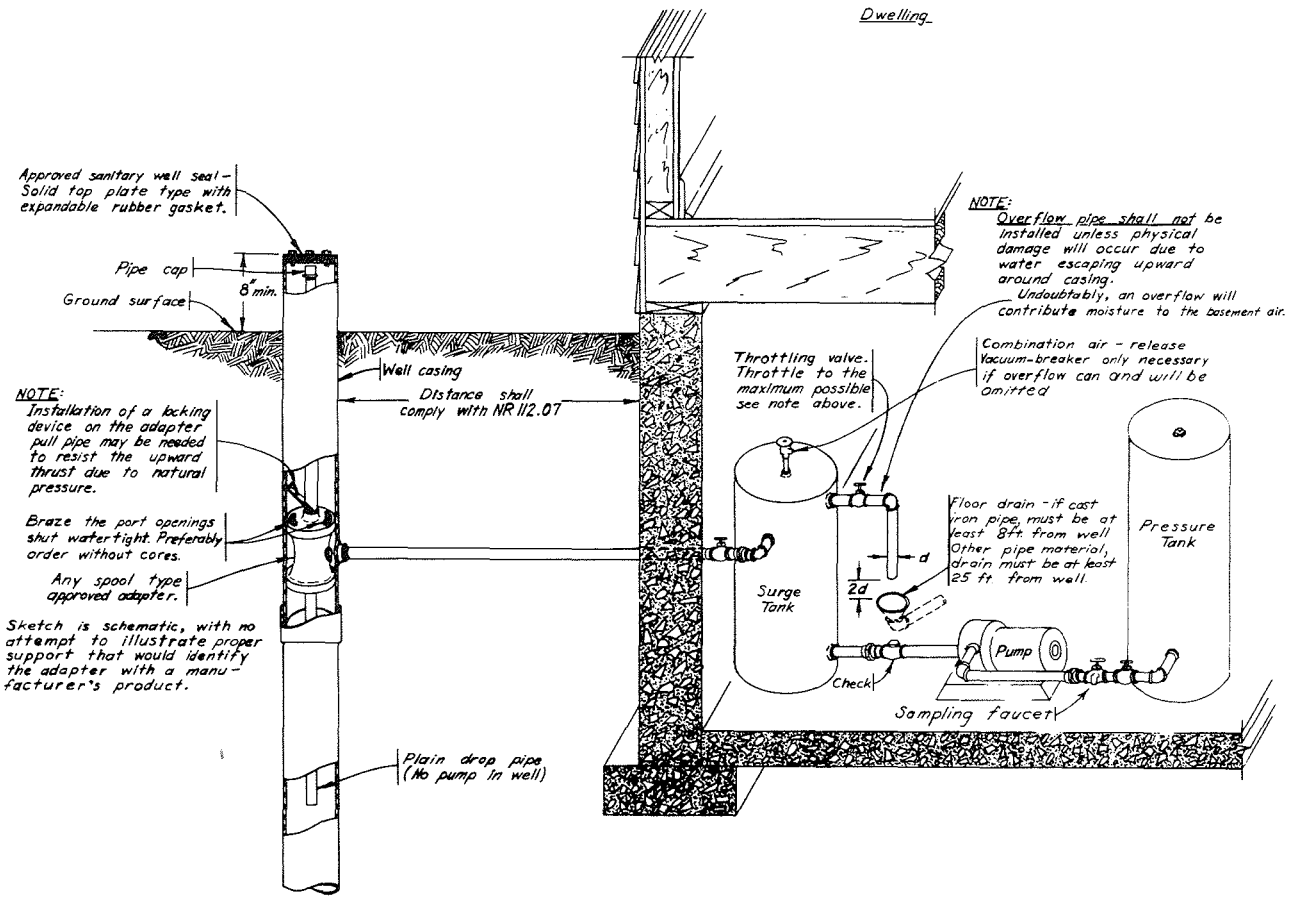

Figure 23. Pump Installation for Flowing Well Using an Approved Pitless Adapter, Surge Tank and Booster Pump, with Overflow Provision off the Surge Tank, if necessary.

Register, June, 1975, No. 234
Environmental Protection

NOTE:

Well overflow pipe shall only be installed if physical damage would otherwise occur due to water escaping upward around the casing or to prevent freezing of the top of the well, should it not be desired to construct an insulated structure over the well. However, the insulated structure would be preferred for frost protection, should the overflow pipe not be necessary to prevent physical damage to the well.

Throttling valve. Throttle to the maximum possible. See note above.

At least 2 pipe dia. free fall.

Discharge to grade at least 10ft. from well.

An approved type pitless adapter.

Box-shaped louvered structure

Approved sanitary well seal—Solid top plate type with expandable rubber gasket.

Ground surface

Alternate—without pitless adapter

Distance shall comply with NR 112.07

Plain drop pipe (No pump in well)

Dwelling

Combination air-release, vacuum-breaker only necessary if overflow on tank will be omitted.

Undoubtedly, overflow will contribute moisture to the basement air.

Throttling valve. Throttle to the maximum possible. See note above.

Overflow outlet for surge tank shall be several inches higher than supply pipe inlet.

Floor drain—if cast iron pipe must be at least 8ft. from well. Other pipe material, drain must be at least 25 ft. from well.

Figure 24 Pump Installation for Flowing Well Showing alternatives of Above-Ground Discharge or Approved Pitless Adapter Installation with a Surge Tank and Water Pump and Overflow Options at the Surge Tank or Top of the Well, if either is necessary.

NR 112.18 Well construction equipment. (1) **ADEQUACY.** Every registered well driller shall be adequately equipped or shall have ready access to adequate equipment to enable him to fully comply with all regulatory requirements applicable to any construction undertaken by him.

(2) **IDENTIFICATION.** The well driller's name and current permit number shall be conspicuously displayed on every well construction job, preferably on his equipment, but may be displayed on a temporary sign.

History: Cr. Register, June, 1975, No. 234, eff. 10-1-75.

NR 112.19 Concrete and grout mixtures. (1) **CONCRETE AGGREGATE AND MIXTURE.** (a) Concrete for use in construction of wells, well platforms and pump floors shall be made of clean, hard, tough and durable aggregates. The maximum diameter of aggregate particles shall not exceed $1/5$ of the minimum width between forms. The fine aggregate, or sand, should be separated from the coarse aggregate by means of $1/4$ inch screen and the ratio of coarse aggregate to fine aggregate shall be about $1\frac{1}{2}$ to 1, by volume. This ratio shall not exceed 2 to 1 nor be less than 1 to 2. From 30 to 70% of the sand passing a $1/4$ inch screen should be retained on a number 30 sieve.

(b) In proportioning concrete, sufficient sand and coarse aggregate shall be mixed to make approximately 3 cubic feet of mixed aggregate. To this aggregate shall be added 1 sack of cement and $5\frac{1}{2}$ gallons of water. If the aggregate is wet, the water ratio shall be no more than 5 gallons per sack of cement. The consistency shall be wet enough to permit easy placement without an excess of water.

(2) **CONCRETE GROUT.** The mixture shall consist of cement, sand and water in the proportion of one bag of cement (94 pounds), and an equal volume of dry sand, and 5 to 6 gallons of clean water. It may be used in lieu of cement grout in the dry portion of a hole but only if applied through a conductor pipe extending to the point of placement and department approval has been received pursuant to NR 112.04.✓

(3) **NEAT CEMENT GROUT.** Neat cement grout shall consist of cement and water in the proportion of one bag of cement (94 pounds) to 5 to 6 gallons of clean water. Approved ingredients to increase fluidity, reduce shrinkage or control time of set may be used in a grout mixture.

History: Cr. Register, June, 1975, No. 234, eff. 10-1-75.

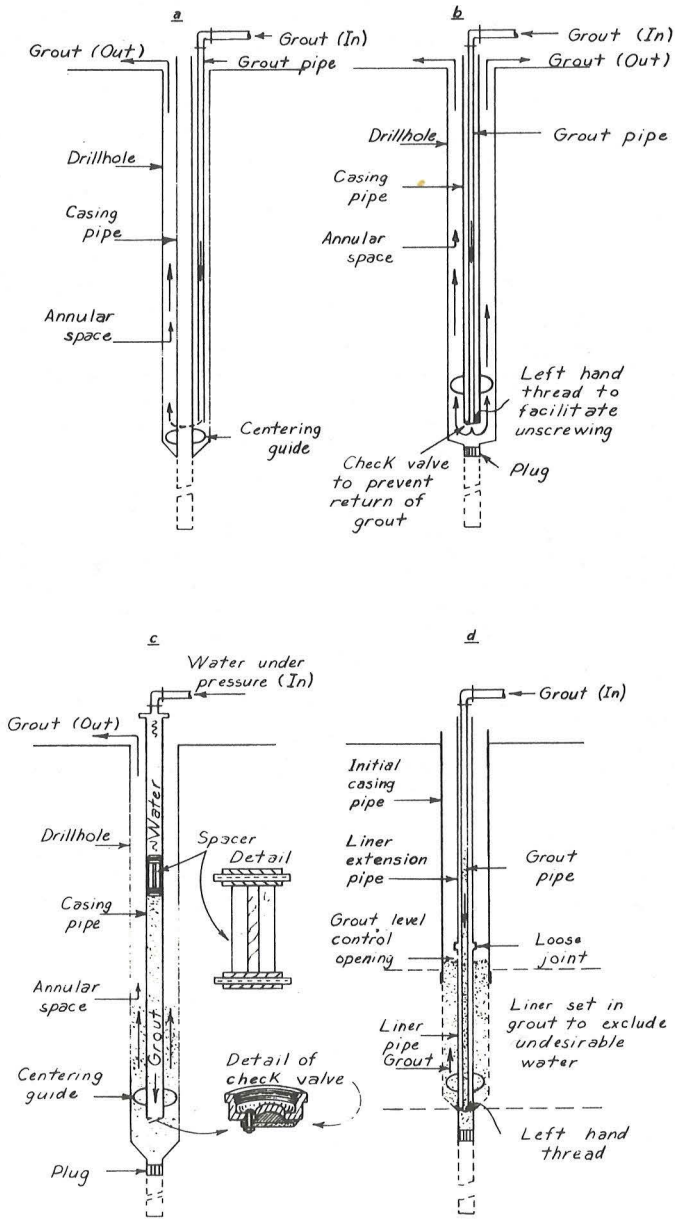

Figure 25. Arrangements for Grouting Annular Space.

NR 112.20 Well disposal of pollutants. The use of any well for disposal of solid wastes, sewage or surface or wastewater drainage is prohibited. (Note: See NR 112.03 (51) for definition of sewage.)

History: Cr. Register, June, 1975, No. 234, eff. 10-1-75.

NR 112.21 Abandonment of wells. (1) **METHODS.** When a well is permanently abandoned the owner thereof shall remove from the well any debris, pump, piping, unsealed liners or other obstruction that may interfere with sealing operations and fill and seal the well in such manner as to prevent it from acting as a channel for contamination or vertical movement of water by using one of the following methods:

(a) *Drift or other unconsolidated formation wells.* Such wells shall be filled entirely with concrete or clean clay slurry, in which latter case a concrete plug at least 20 feet thick shall be poured at the top of the well. Inner ungrouted well casing and screen shall be removed from gravel-pack wells prior to filling. The top 7 feet of curbing shall be removed prior to filling dug or bored wells.

(b) *Limestone formation wells.* Preferably any limestone strata shall be filled entirely with concrete. As an alternate, layers of concrete and gravel or stone aggregate may be used except that the top 20 feet of the rock formation and the entire cased portion shall likewise be filled with concrete. An exception to filling the cased portion with concrete under the alternate method may be made where the well casing is set in rock and sealed in place with cement grout. In such a case, a concrete plug at least 40 feet thick shall be placed extending at least 20 feet above and below the bottom of the casing. The remainder of the cased portion up to 20 feet from the surface may be filled with gravel, crushed rock, sand or clay slurry, provided that the top 20 feet shall also be filled with concrete.

(c) *Sandstone formation wells.* Preferably any sandstone formations shall be filled entirely with concrete. As an alternate, disinfected sand or pea gravel may be used except that the top 20 feet of the formation and the entire cased portion in this alternate method shall likewise be filled with concrete. An exception to entirely filling the well casing with concrete may be made where the well casing is set in rock and sealed in place with cement grout. In such a case, a concrete plug at least 40-feet thick shall be placed extending at least 20 feet above and below the bottom of the casing. The remainder of the cased portion up to 20 feet from the surface may be filled with pea gravel, sand or clay slurry, provided that the top 20 feet shall also be filled with concrete.

(d) *Shale rock, granite and quartzite formation wells.* The same procedure as with limestone formation wells shall be used.

(e) *Mixed formation wells.* Drift or other unconsolidated formations, limestone, sandstone, shale, granite and quartzite strata shall be filled in compliance with NR 112.21 (1) (a), (b), (c) and (d). Where the alternate methods to filling the well entirely with concrete are selected, concrete or concrete grout plugs at least 40 feet in depth, extending at least 20 feet above and below the point of surface contact between every recognized different geologic formation shall be provided.

(f) *Flowing wells.* In filling flowing wells the flow shall be confined by extending well casing pipe, if possible, and the well shall be filled with materials in accord with applicable preceding subsections or with cement grout applied by a pressure method.

(g) *Sealing procedure restriction.* Filling material for nonflowing wells shall be applied through a conductor pipe except that when practical a dump bailer may be used. When concrete is placed under water by a conductor pipe, the bottom end of the conductor pipe shall be submerged in the concrete at all times.

(2) **TEMPORARY ABANDONMENT.** When a well is temporarily removed from service the top shall be sealed with a watertight threaded or welded cap or it shall be filled with clean clay slurry.

(3) **REPORT TO DEPARTMENT.** A report shall be made to the department by the owner of every well which has been permanently abandoned or temporarily removed from service. Such report shall include a detailed description of location, construction and geologic features and method of sealing.

History: Cr. Register, June, 1975, No. 234, eff. 10-1-75.

NR 112.22 Cooperation with the department. Well drillers and pump installers shall, when requested by the department, do the following:

(1) Give at least 48 hours notice to the department of the day and date upon which any well under construction, or part thereof, or any installation of pumping equipment, or part thereof, by such driller or installer, or any employee or agent thereof, will be completed.

(2) Assist the department in ascertaining the size, depth and character of the construction for any such well or the character of the installation of the pumping equipment.

(3) Assist the department in obtaining and determining the character of the samples of water from any such well.

(4) Assist the department in conducting necessary tests.

(5) Provide such other information as may be required by the department in order to determine if such well has been constructed or any equipment has been installed in accordance with the provisions of this chapter or with approved comparable construction.

History: Cr. Register, June, 1975, No. 234, eff. 10-1-75.

NR 112.23 Standards for existing installations. (1) **LOCATION AND CONSTRUCTION.** Each existing water supply system shall be viewed as an individual unit and its safety shall be determined on the basis of its location and construction.

(a) *Location.* The location shall reasonably conform to the provisions of NR 112.07.

(b) *Construction.* The underground construction shall be in reasonable compliance with NR 112.08 as to depth and type of casing and curbing. Existing well pits, pump pits, pressure-tank pits, pressure-tank access pits and subsurface pumphrooms adjoining basements shall meet the following requirements:

1. The floor and roof shall be crack-free poured concrete having a thickness of at least 4 inches. The walls shall be 6-inch thick watertight poured concrete or equivalent construction unless the pit or pumphroom has a history of being continuously dry in which case masonry walls of concrete block, brick or stone with mortared joints shall be acceptable. A 3-inch thick concrete facing on substantial masonry walls shall be accepted as equivalent wall construction. The junction of walls and floors shall be watertight. The roof or deck shall be above the ground surface.

2. The well pit shall be fitted with a manhole opening having a raised curbing edge at least 4 inches thick and at least 4 inches higher than the pit roof. A substantial, watertight, overlapping, tight-fitting cover with skirted sides shall be provided for the manhole. The cover preferably shall be constructed with welded sheet steel but it may be constructed out of lumber covered with sheet metal or tin.

3. The subsurface pumphroom shall either have a manhole as in NR 112.23(1) (b) 2, or a section of well casing pipe with diameter equal to or greater than the well casing, installed directly above the well casing and sealed with an approved type well seal or cap.

4. Where practical the pit shall be drained by a separate watertight, metal gravity type drain discharging to the ground surface, such drain being constructed either with steel or with cast iron pipe. When such a drain is not installed, a watertight sump shall exist. If ground water gains access to the pit through the floor or walls, the pit shall be abandoned and filled after extension of the well casing with an acceptable joint. A subsurface pumphroom adjoining a basement may be drained to the basement provided the basement in turn is adequately drained. Otherwise a partition wall at least 1 foot high in the pumphroom entrance and separate drainage facilities similar to that required for separate pits shall exist. No pit drain or sump pump discharge pipe shall be connected directly with any sewer, other drain or plumbing system.

5. The well casing shall terminate at least 6 inches above the floor of a pit or of a subsurface pumphroom and be provided with an approved type sanitary well seal with metal top and bottom plates, a rubber gasket and draw/bolts.

6. Well pit vent pipes, if used, shall be 2-inch diameter galvanized steel pipes located in opposite corners, one pipe to extend to within 1 foot of the pit floor and the other to extend only through the pit roof. The upper end of each vent pipe shall terminate with a return bend with a screened outlet.

(2) PUMP INSTALLATION. Existing pump installations shall conform to the following requirements:

(a) *Offset units.* The suction line of an offset shallow well pump or the piping of an offset jet pump shall be contained in a sealed conduit between the well and a basement, be connected to the well through a stuffing box or short sealed conduit in a conforming well pit, or be connected to the well with a pitless adapter approved prior to April 10, 1953. Nonpressure conduit shall enter the basement so that the bottom of the conduit is at least 6 inches above the basement floor. (Note: It is recommended that the pump impeller or cylinder of

pump units located in basements be located above the ground level or be at least 2 feet above the floor.)

(b) *Pit setting.* A deep well reciprocating, turbine or jet pump and set-length type force pump located in a conforming pit shall be so installed as to permit the sealing of the top of the well with an approved type watertight sanitary well seal with gasket, or an equivalent watertight connection with the pump. Any well vent pipe shall extend to the ceiling of the pit and terminate with a return bend and shall have a screened outlet.

(c) *Hand type pumps.* Hand type pumps may be continued in service provided that the pump base flange rests upon a casing flange and the flanges are separated by a gasket. The casing flange must be placed at least 6 inches above the ground or a concrete pump platform. If water is pumped from a hand pump to a reservoir, the piping attachment to the pump shall be made with permanent pipe fittings. Whenever a reservoir exists, the discharge pipe from the pump shall enter the reservoir in a watertight manner through that portion of the structure extending above the ground grade unless a subsurface reservoir supply line is connected to the well by an approved type pitless adapter for a submersible or deep well reciprocating pump and the supply line can be maintained under a positive head of at least 5 feet. The supply pipe in such case shall terminate at or no more than a few inches above the bottom of the reservoir and a float control switch or low and high water level electrical pump-control rods shall exist. Any check valve shall exist only in the portion of the pump discharge pipe located within the well.

(d) *Reservoirs.* 1. The roof of any existing reservoir shall be crack-free, reinforced, poured concrete having a thickness of at least 5 inches. The floor of the reservoir normally shall be crack-free poured concrete at least 4 inches thick. The walls of the reservoir shall be crack-free, reinforced, poured concrete at least 5 inches thick or equivalent construction. A 3-inch thick reinforced concrete facing on substantial masonry walls may be accepted as equivalent wall construction. Exception to this requirement will be made where masonry with mortared joints has been used in the construction of the walls, or roof or both and the masonry is crack-free.

2. The manhole curbing shall extend at least 12 inches above the ground grade unless the reservoir roof terminates above the ground grade, in which case the curbing shall terminate at least 6 inches above the reservoir roof. The manhole shall be provided with a tight-fitting, overlapping cover with a minimum of 3-inch wide skirted sides. The manhole cover shall preferably be constructed of welded sheet steel but one constructed of concrete will be acceptable. The manhole cover shall be fitted snugly over the manhole curbing so as to prevent entrance of insects and vermin into the reservoir.

3. Any reservoir overflow pipe shall be located just under the roof of the reservoir and entirely above the ground grade and terminate with a down-turned pipe with a screened outlet at a point at least 12 inches above the ground grade. If an existing overflow pipe is totally buried between the reservoir and its outlet, it shall be eliminated by properly sealing the pipe with concrete back to the reservoir.

4. The reservoir location shall be equivalent to that required for an existing well.

(3) **INSPECTIONS.** Inspections of existing installations will be made for problem water supplies and also those requiring certification when staff are available to provide such service.

History: Cr. Register, June, 1975, No. 234, eff. 10-1-75.

NR 112.24 Severability. Should any section, paragraph, phrase, sentence, clause or word of this chapter be declared invalid or unconstitutional for any reason, the remainder of this chapter shall not be affected thereby.

History: Cr. Register, June, 1975, No. 234, eff. 10-1-75.

NR 112.25 Effective date. This chapter shall become effective 90 days following publication.

History: Cr. Register, June, 1975, No. 234, eff. 10-1-75.

Appendix

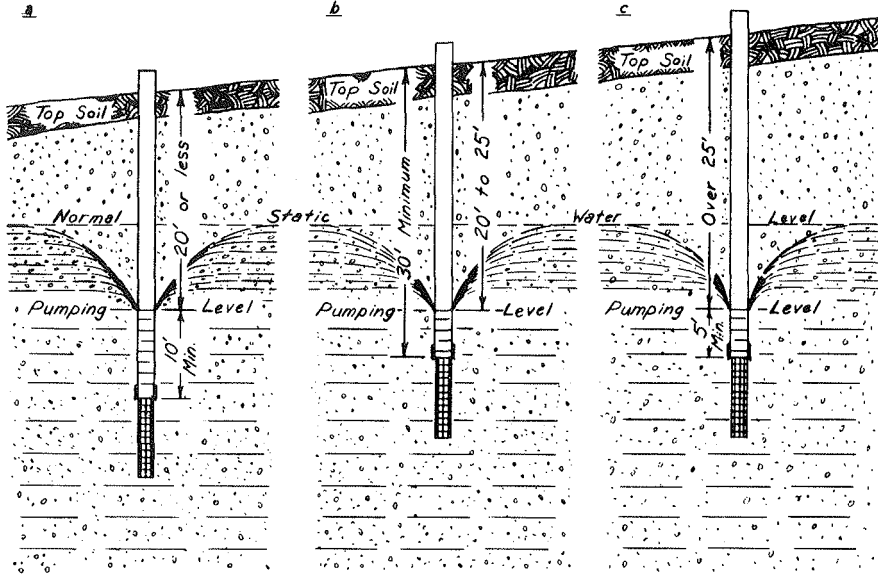

Figure A-1. Construction of Wells in Sand and Gravel with Screens, by Percussion Equipment. See Table 1, a.

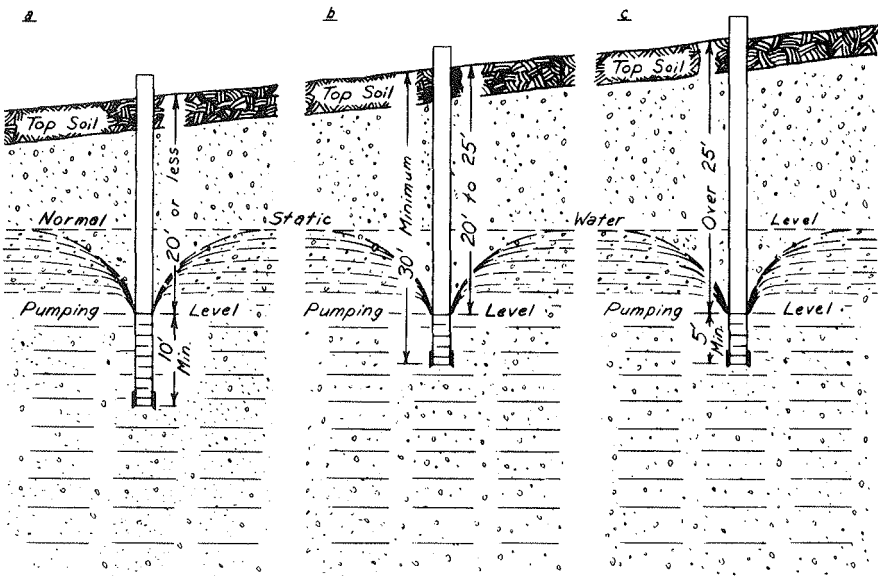

Figure A-2. Construction of Wells in Sand and Gravel without Screens, by Percussion Equipment. See Table 1, a.

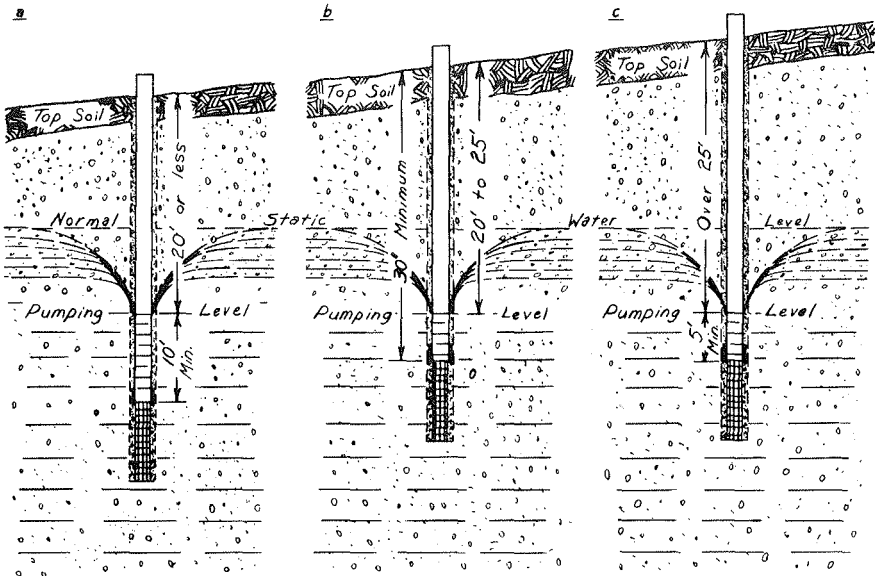

Figure A-3. Construction of Wells in Sand and Gravel with Screens, by Rotary Equipment. See Table 1, a.

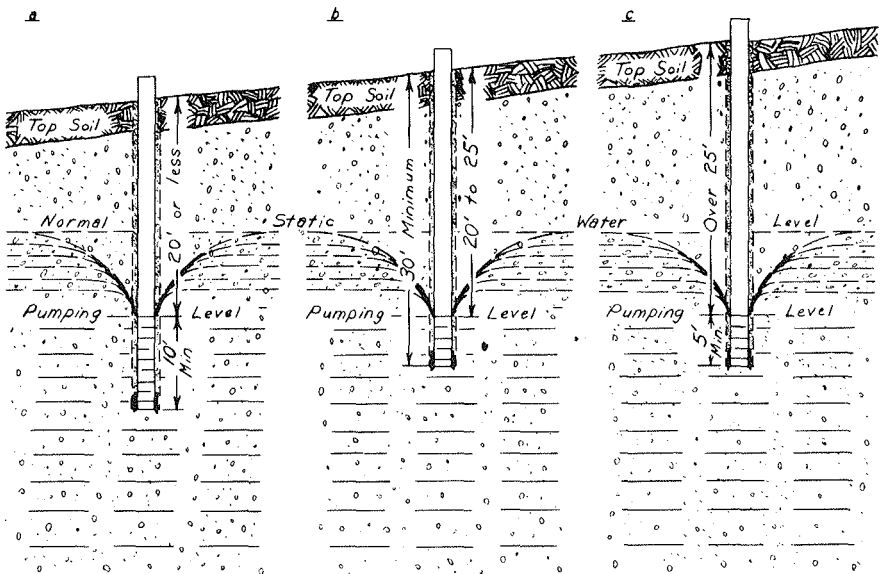

Figure A-4. Construction of Wells in Sand and Gravel without Screens, by Rotary Equipment. See Table 1, a.

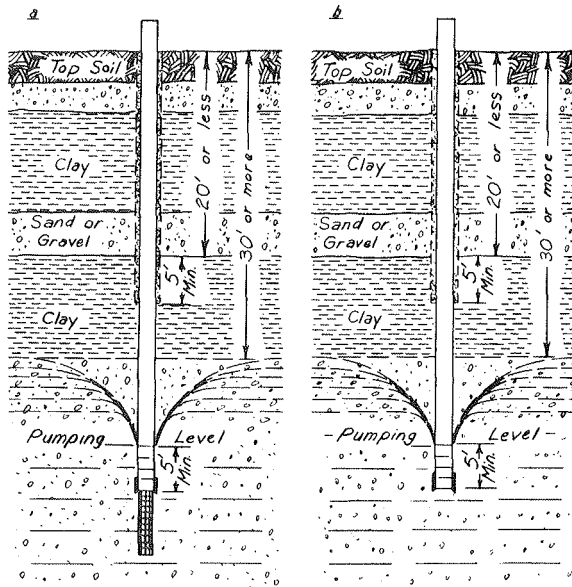

Figure A-5. Construction of Wells Terminating in Sand and Gravel Underlying Clay or Similar Material containing layers of Sand and Gravel, with and without Screens, by Percussion Equipment. See Table 1, b.

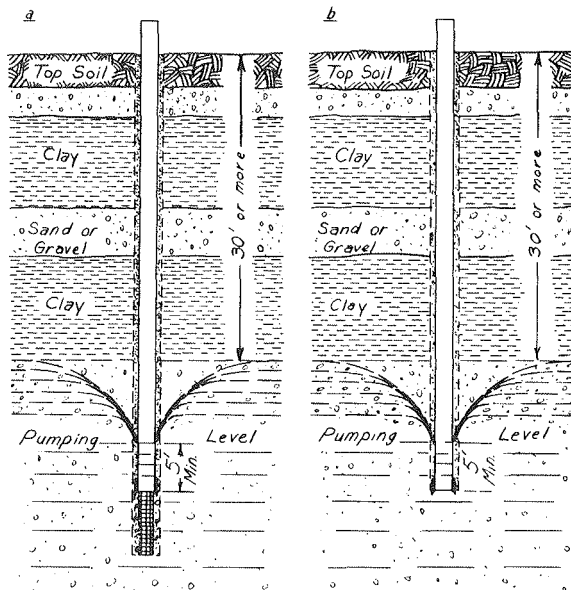

Figure A-6. Construction of Wells Terminating in Sand and Gravel Underlying Clay or Similar Material containing layers of Sand and Gravel, with and without Screens, by Rotary Equipment. See Table 1, b.

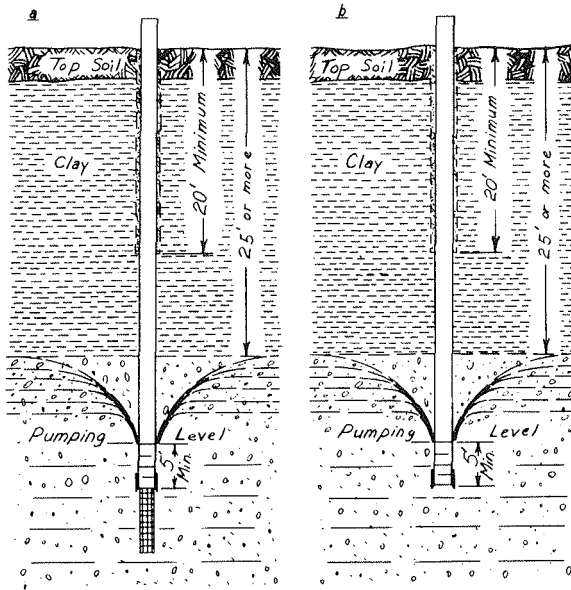

Figure A-7. Construction of Wells Terminating in Sand and Gravel Underlying Clay or Similar Material, with and without Screens, by Percussion Equipment. See Table 1, c.

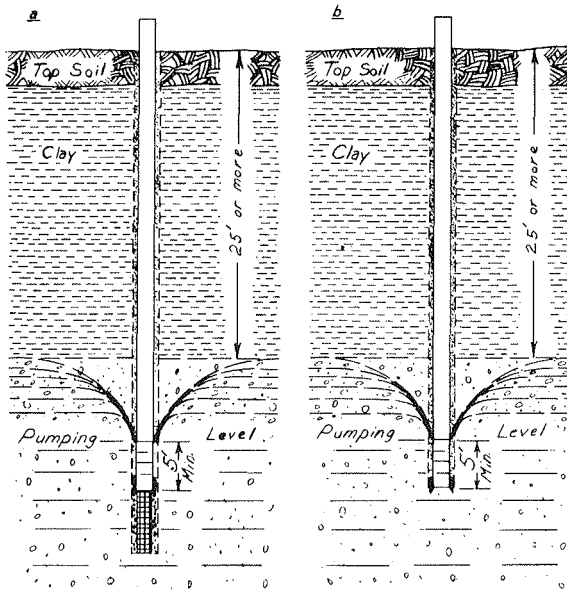

Figure A-8. Construction of Wells Terminating in Sand and Gravel Underlying Clay or Similar Material, with and without Screens, by Rotary Equipment. See Table 1, c.

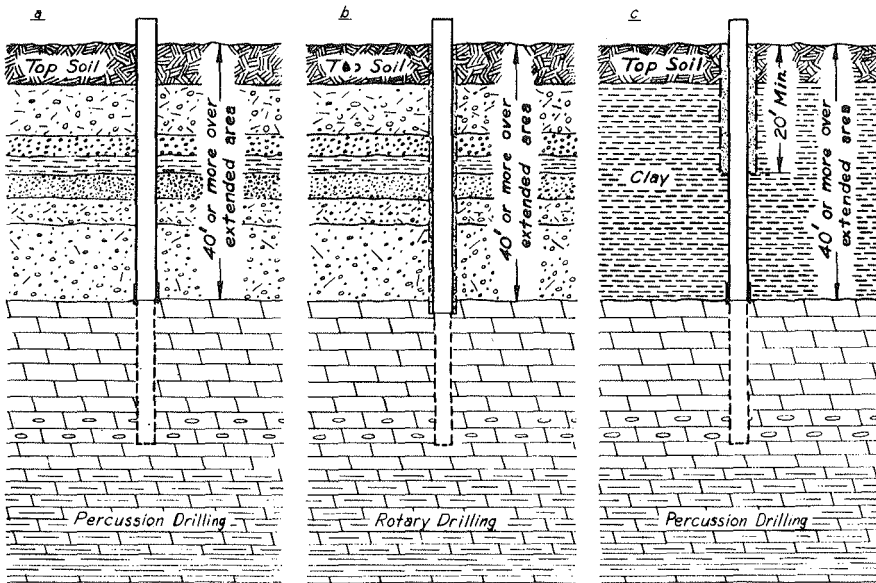

Figure A-9. Construction of Wells Terminating in Limestone Underlying Unconsolidated Materials comprising Mainly Sand and Gravel or Clay or Similar Material, extending to a depth of 40 feet or greater depth. See Table 1, d and e.

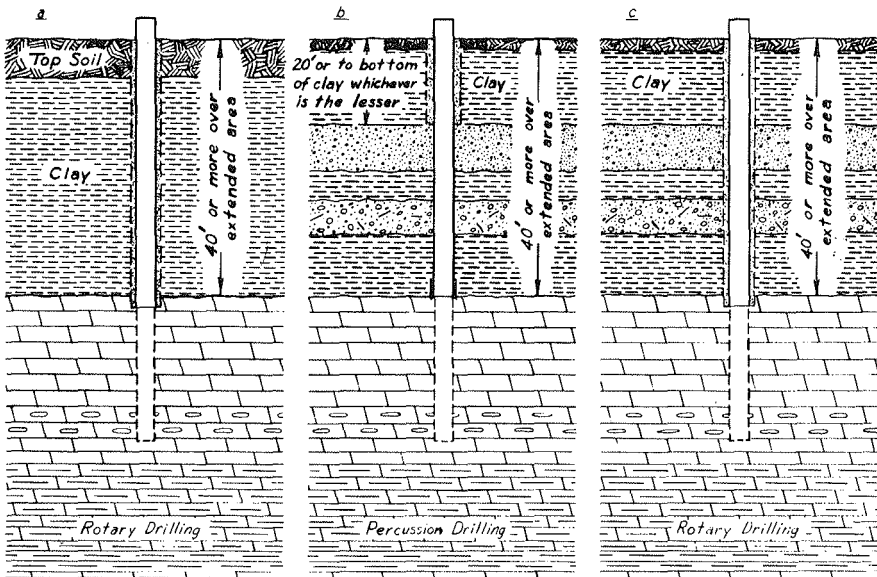

Figure A-10. Construction of Wells Terminating in Limestone Underlying Clay or Similar Materials or such materials with some Sand and Gravel Zones, extending to a depth of 40 feet or greater depth. See Table 1, e.

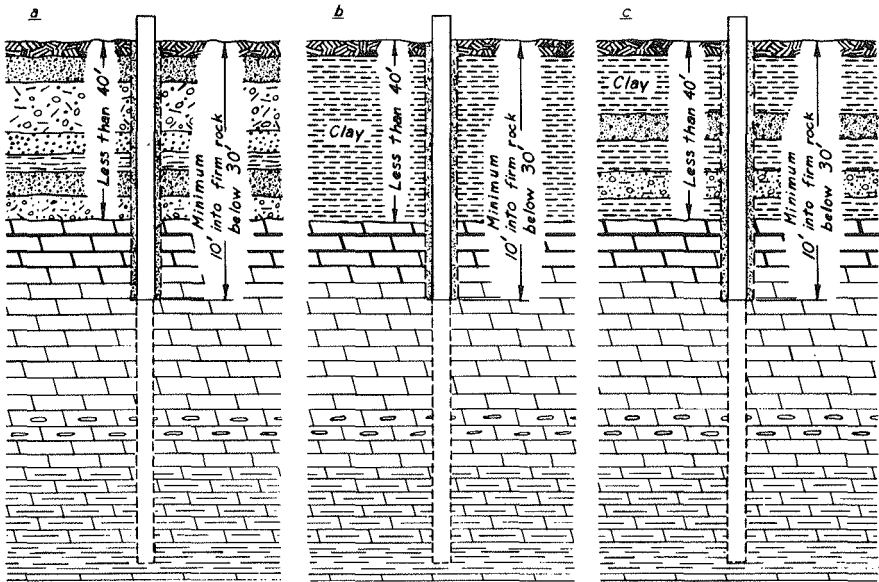

Figure A-11. Construction of Wells Terminating in Limestone Underlying Unconsolidated Materials comprising mainly Sand and Gravel, or Clay or Similar Material or a Mixture of Sand, Gravel and Clay or Similar Material, extending to a depth of less than 40 feet by either Percussion or Rotary Equipment. See Table 1, f.

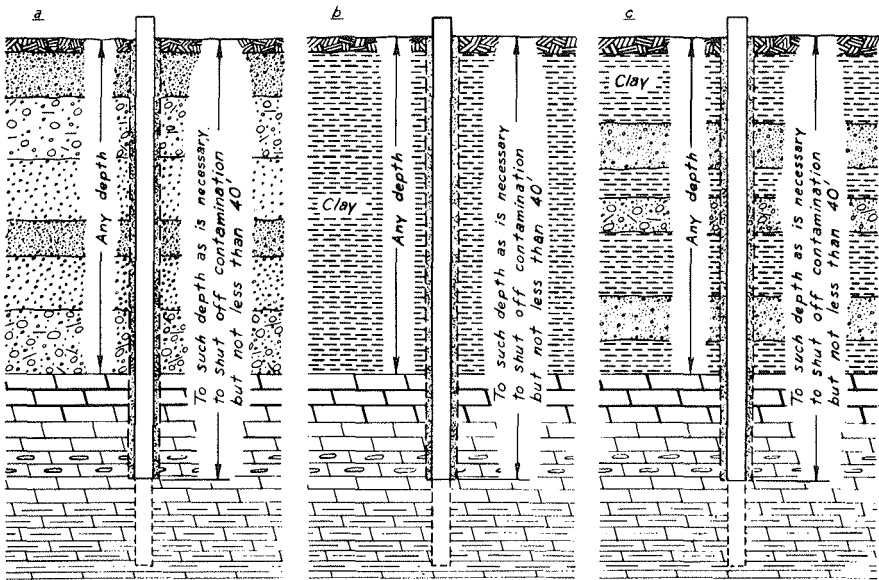

Figure A-12. Construction of Wells Terminating in Limestone Underlying Unconsolidated Materials comprising mainly Sand and Gravel, or Clay or Similar Material or a Mixture of Sand, Gravel and Clay or Similar Material, extending to variable depths, by either Percussion or Rotary Equipment. See Table 1, d, e and f.

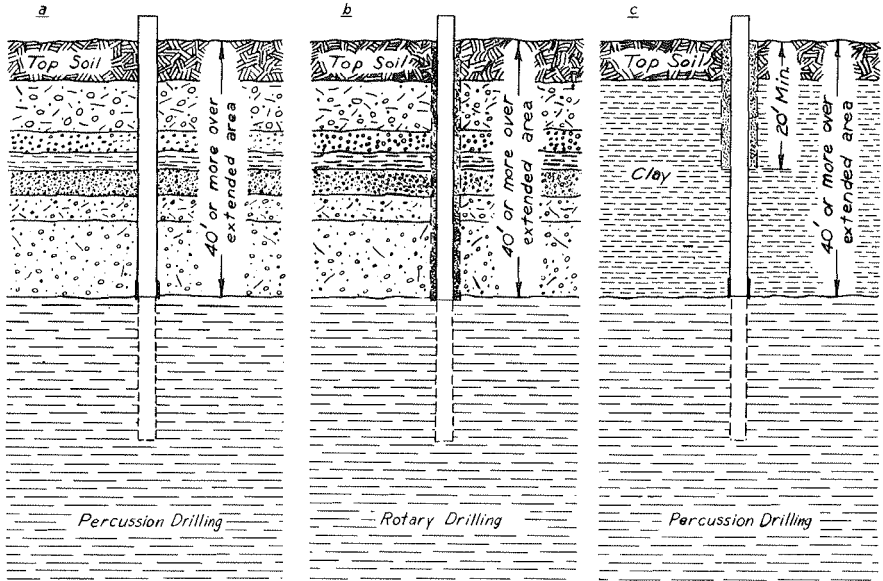

Figure A-13. Construction of Wells Terminating in Shale Underlying Unconsolidated Materials comprising mainly Sand and Gravel or Clay or Similar Material, extending to a depth of 40 feet or greater depth. See Table 1, g and h.

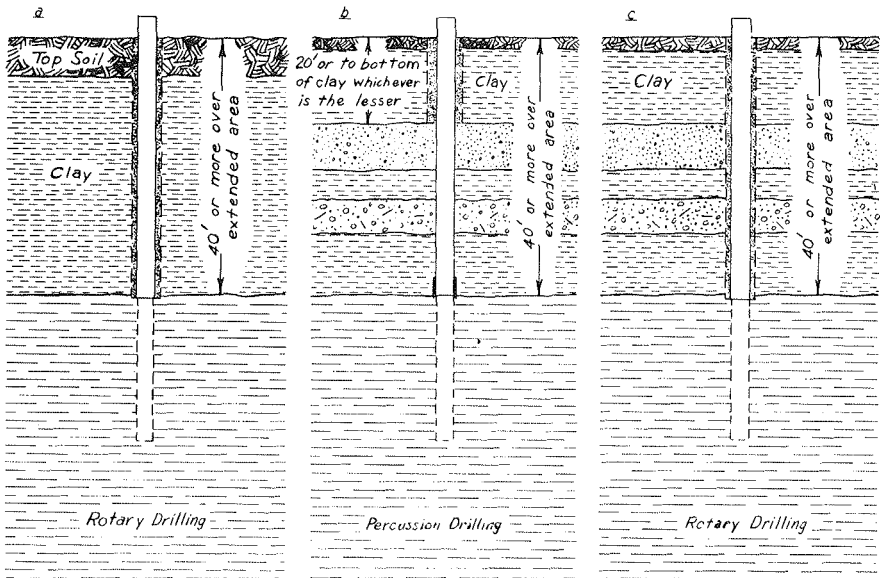

Figure A-14. Construction of Wells Terminating in Shale Underlying Clay or Similar Material or such materials with some Sand and Gravel Zones, extending to a depth of 40 feet or greater depth. See Table 1, h.

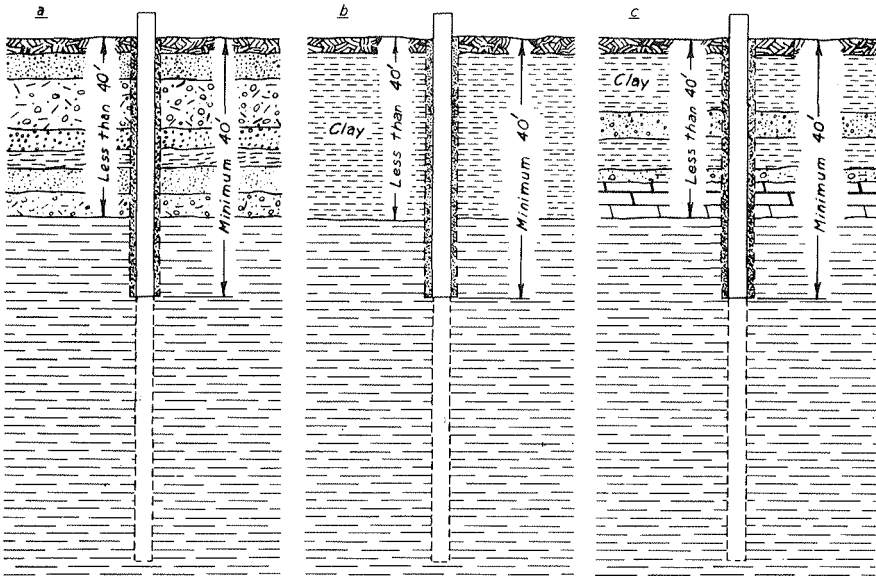

Figure A-15. Construction of Wells Terminating in Shale Underlying Unconsolidated Materials comprising mainly Sand and Gravel, or Clay or Similar Material, or a Mixture of Sand, Gravel and Clay or Similar Material, extending to a depth of less than 40 feet, by either Percussion or Rotary Equipment. See Table 1, i.

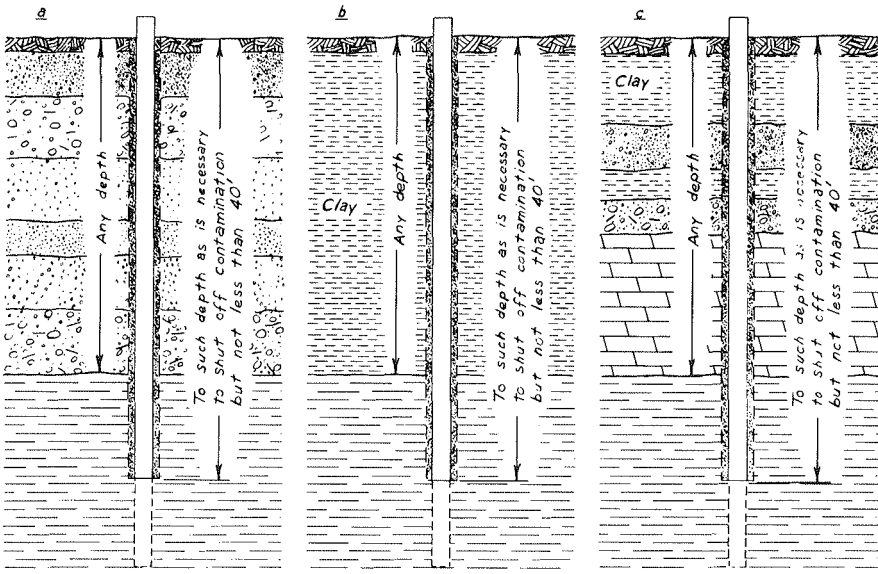

Figure A-16. Construction of Wells Terminating in Shale Underlying Unconsolidated Materials comprising mainly Sand and Gravel, or Clay or Similar Material, or a Mixture of Sand, Gravel and Clay or Similar Material, extending to variable depths, by either Percussion or Rotary Equipment. See Table 1, g, h and i.

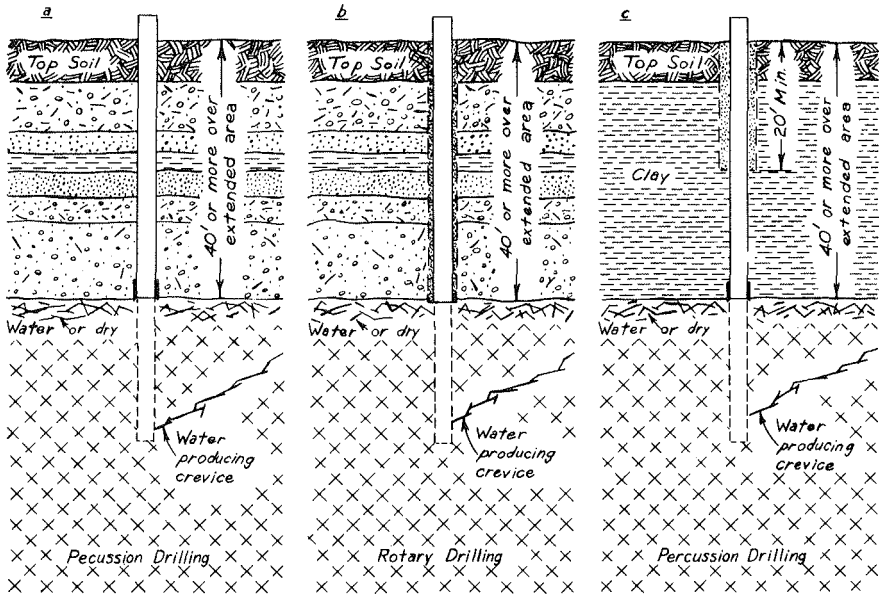

Figure A-17. Construction of Wells Terminating in Granite or Quartzite Underlying Unconsolidated Materials, comprising mainly Sand and Gravel or Clay or Similar Material, extending to a depth of 40 feet or greater depth. See Table 1, j and k.

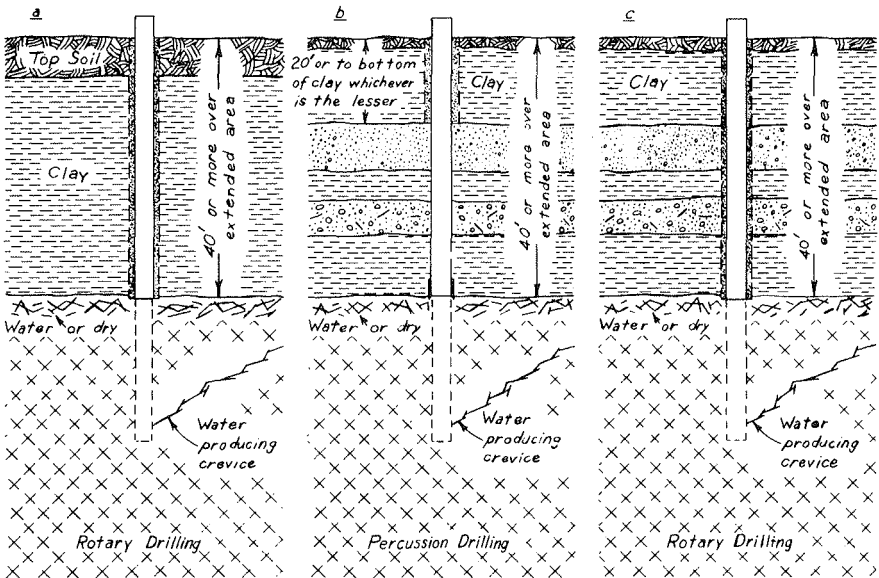

Figure A-18. Construction of Wells Terminating in Granite or Quartzite Underlying Clay or Similar Material or such Materials with some Sand and Gravel Zones, extending to a depth of 40 feet or greater depth. See Table 1, k.

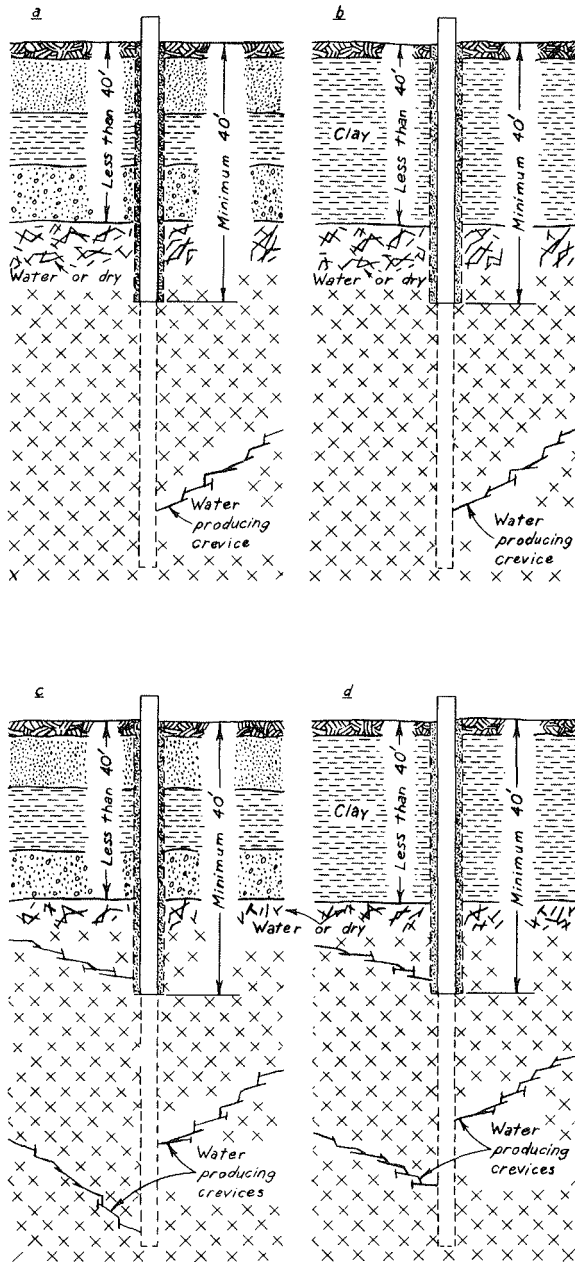

Figure A-19. Construction of Wells Terminating in Granite or Quartzite Underlying Unconsolidated Materials, extending to a depth of less than 40 feet, by either Percussion or Rotary Equipment. See Table 1, l.

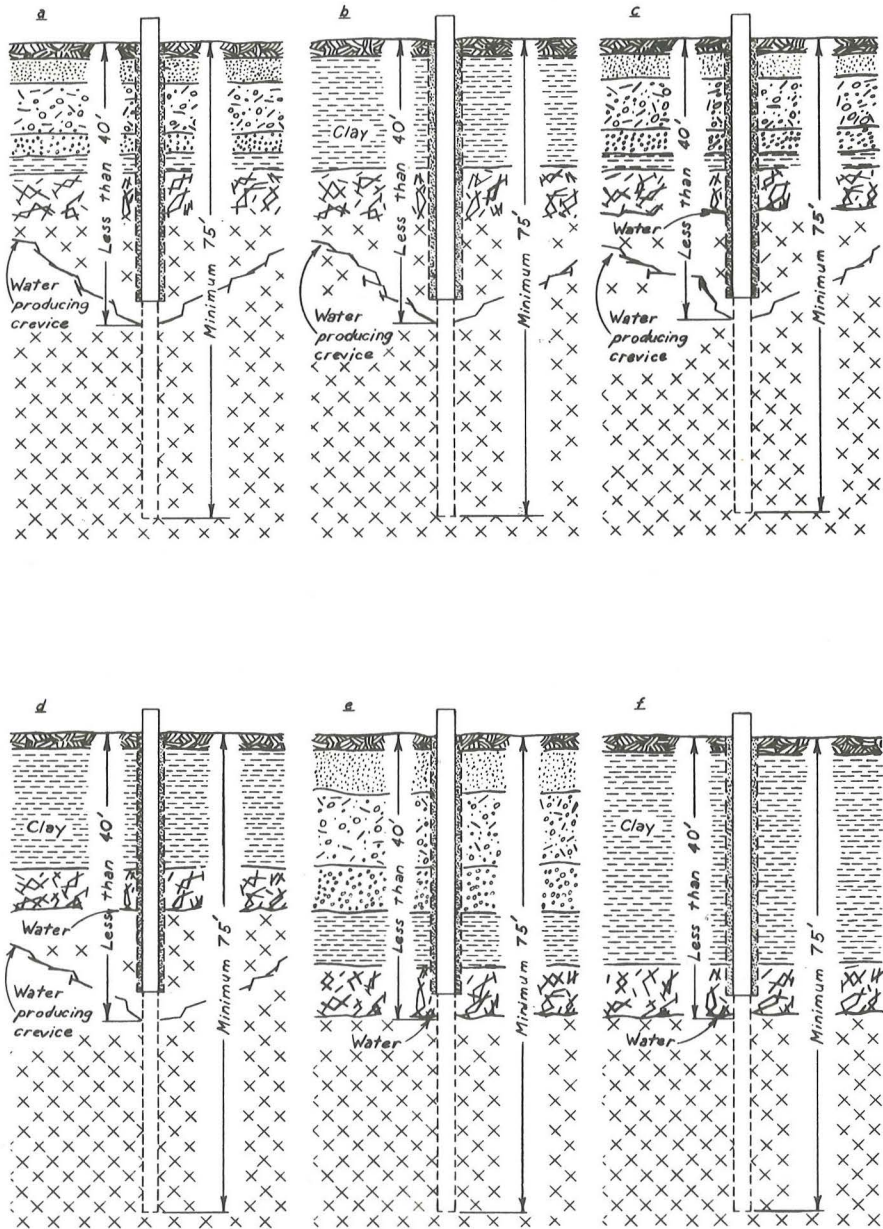

Figure A-20. Construction of Wells Terminating in Granite or Quartzite Underlying Unconsolidated Materials comprising mainly Sand and Gravel, or Clay or Similar Material or a Mixture of Sand, Gravel and Clay or Similar Material, extending to a depth of less than 40 feet, by either Percussion or Rotary Equipment. Permission is required to construct a well with less than 40 feet of well casing pipe. See Table 1, I.

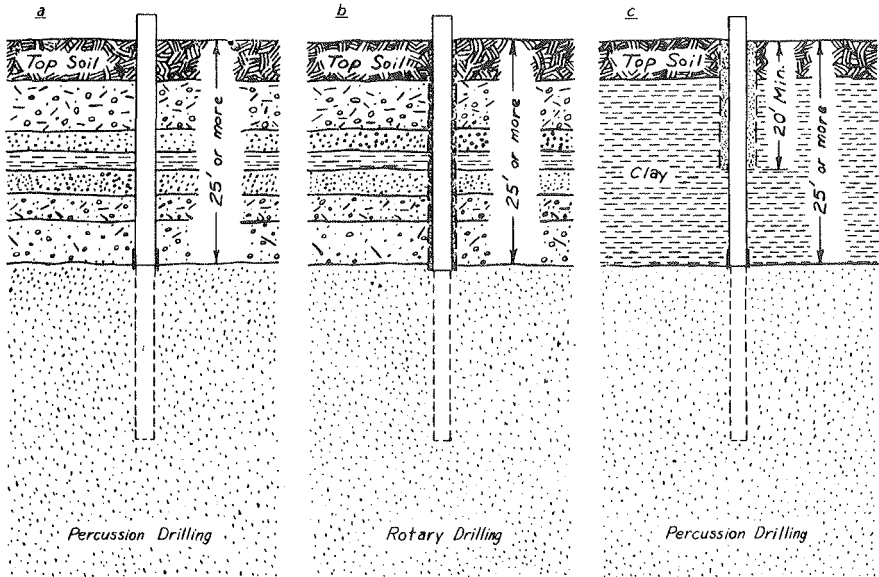

Figure A-21. Construction of Wells Terminating in Sandstone Underlying Unconsolidated Materials comprising mainly Sand and Gravel, or Clay or Similar Material, extending to a depth of 25 feet or greater depth. See Table 1, m and n.

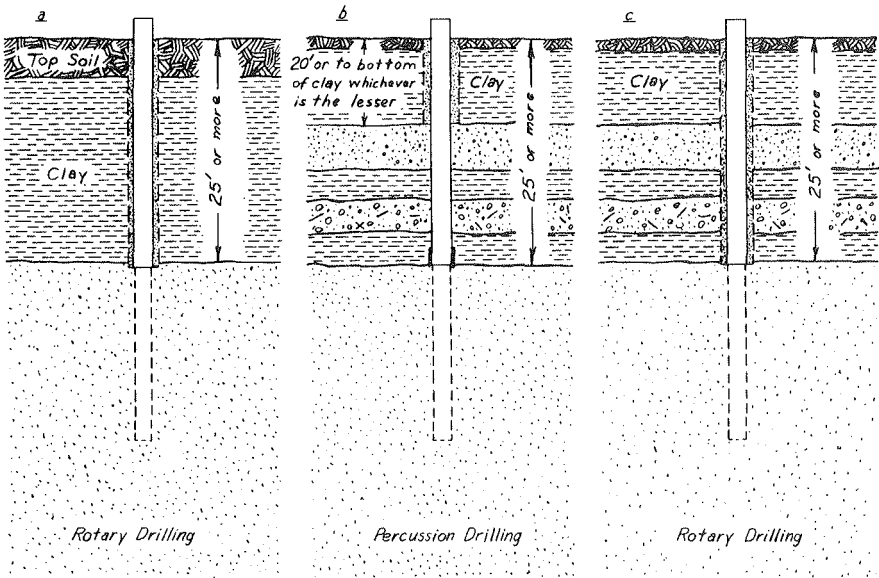

Figure A-22. Construction of Wells Terminating in Sandstone Underlying Clay or Similar Material or such Materials with some Sand and Gravel, extending to a depth of 25 feet or greater depth. See Table 1, n.

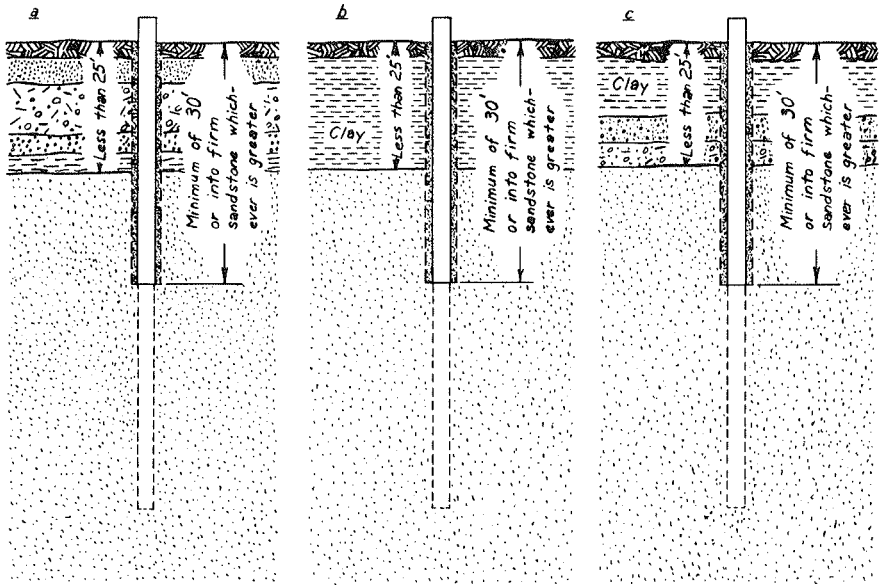

Figure A-23. Construction of Wells Terminating in Sandstone Underlying any Material except Limestone, extending to a depth of less than 25 feet, by either Percussion or Rotary Equipment. See Table 1, o.

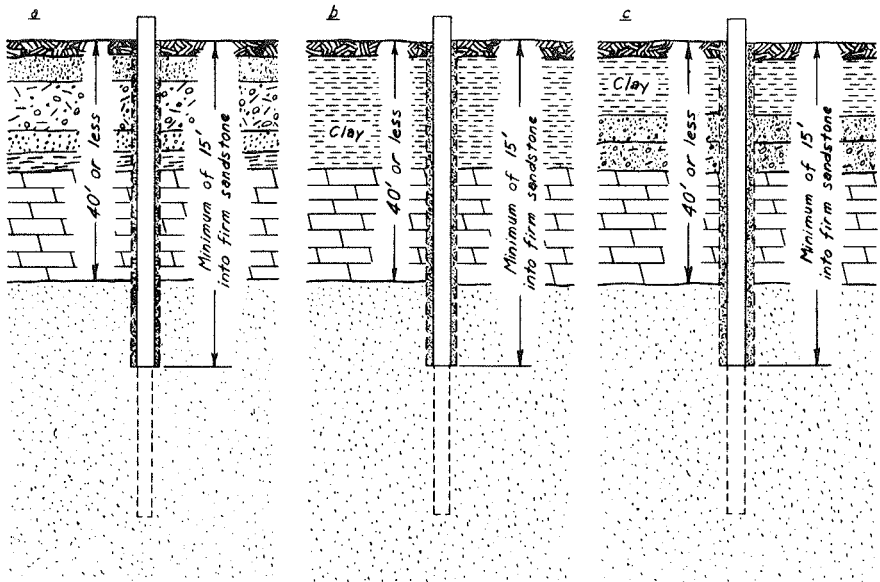

Figure A-24. Construction of Wells Terminating in Sandstone Underlying Limestone extending to a depth of 40 feet or less with or without Unconsolidated Overburden over the Limestone, by either Percussion or Rotary Equipment. See Table 1, p.

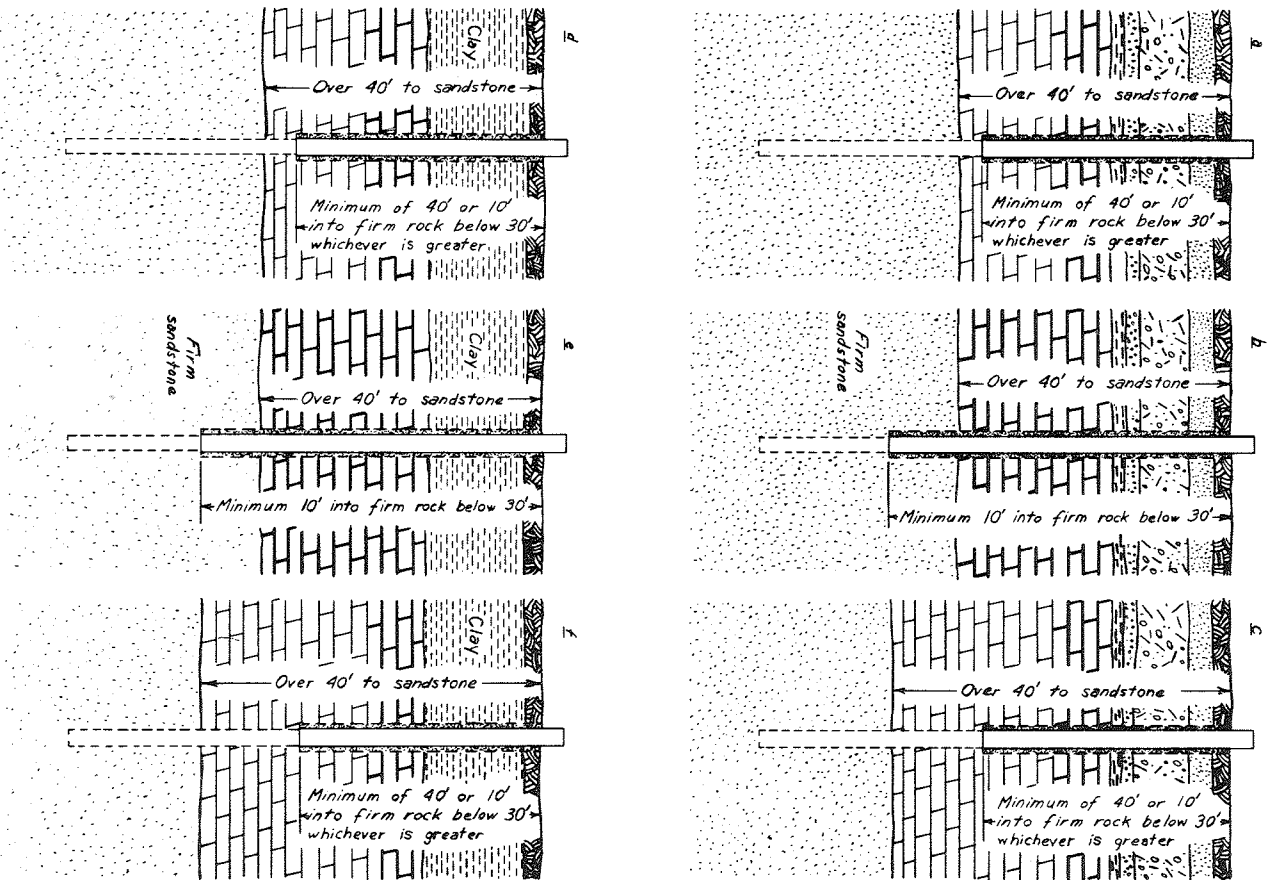

Figure A-25. Construction of Wells Terminating in Sandstone Underlying Limestone extending to a depth greater than 40 feet with or without Unconsolidated Overburden over the Limestone, by either Percussion or Rotary Equipment. See Table I, 9.