

Chapter ILHR 20-25

APPENDIX

Wisconsin Department of Industry, Labor and Human Relations Safety and Buildings Division P.O. Box 7969 Madison, WI 53707 Wisconsin Statutes 101.63, 101.73		WISCONSIN UNIFORM BUILDING PERMIT APPLICATION (See instructions on back of pink copy) The information you provide may be used by other government agency programs (Privacy Law, s. 15.04(1)(m)).		Application No. _____ Parcel No. _____															
PERMIT REQUESTED <input type="checkbox"/> Constr <input type="checkbox"/> HVAC <input type="checkbox"/> Elec <input type="checkbox"/> Plbg <input type="checkbox"/> Erosion <input type="checkbox"/> Other: _____																			
Owner's Name _____		Mailing Address _____		Telephone No. () _____															
Contractor's Name: <input type="checkbox"/> Con <input type="checkbox"/> Elec <input type="checkbox"/> HVAC <input type="checkbox"/> Plbg Lic/Cert # _____		Mailing Address _____		Telephone No. () _____															
Contractor's Name: <input type="checkbox"/> Con <input type="checkbox"/> Elec <input type="checkbox"/> HVAC <input type="checkbox"/> Plbg Lic/Cert # _____		Mailing Address _____		Telephone No. () _____															
Contractor's Name: <input type="checkbox"/> Con <input type="checkbox"/> Elec <input type="checkbox"/> HVAC <input type="checkbox"/> Plbg Lic/Cert # _____		Mailing Address _____		Telephone No. () _____															
Contractor's Name: <input type="checkbox"/> Con <input type="checkbox"/> Elec <input type="checkbox"/> HVAC <input type="checkbox"/> Plbg Lic/Cert # _____		Mailing Address _____		Telephone No. () _____															
PROJECT LOCATION																			
Building Address _____		Subdivision Name _____		Lot No. _____ Block No. _____															
Zoning District(s) _____		Zoning Permit No. _____		Setbacks: Front _____ ft, Rear _____ ft, Left _____ ft, Right _____ ft															
1. PROJECT <input type="checkbox"/> New <input type="checkbox"/> Repair <input type="checkbox"/> Alteration <input type="checkbox"/> Raze <input type="checkbox"/> Addition <input type="checkbox"/> Move <input type="checkbox"/> Other _____		3. OCCUPANCY <input type="checkbox"/> Single Family <input type="checkbox"/> Two Family <input type="checkbox"/> Garage <input type="checkbox"/> Other (print): _____		6. ELECTRICAL Entrance Panel Size: _____ amp Service: <input type="checkbox"/> Underground <input type="checkbox"/> Overhead															
2. AREA INVOLVED Unfinished Basement _____ Sq ft Living Area _____ Sq ft Garage _____ Sq ft		4. CONST. TYPE <input type="checkbox"/> Site Constructed <input type="checkbox"/> Manufactured <input type="checkbox"/> Concrete <input type="checkbox"/> Masonry <input type="checkbox"/> Treated Wood <input type="checkbox"/> Other _____		9. HVAC EQUIPMENT <input type="checkbox"/> Forced Air Furnace <input type="checkbox"/> Radiant Baseboard or Panel <input type="checkbox"/> Heat Pump <input type="checkbox"/> Boiler <input type="checkbox"/> Central Air Conditioning <input type="checkbox"/> Other _____															
5. STORIES <input type="checkbox"/> 1 Story <input type="checkbox"/> 2 Story <input type="checkbox"/> Other _____ <input type="checkbox"/> Plus Basement		7. FOUNDATION <input type="checkbox"/> Seasonal <input type="checkbox"/> Permanent <input type="checkbox"/> Other _____		10. PLUMBING <input type="checkbox"/> Sewer <input type="checkbox"/> Municipal <input type="checkbox"/> Septic Permit No. _____															
8. USE <input type="checkbox"/> Seasonal <input type="checkbox"/> Permanent <input type="checkbox"/> Other _____		11. WATER <input type="checkbox"/> Municipal Utility <input type="checkbox"/> Private On-Site Well		12. ENERGY SOURCE <table border="1"> <tr> <th>Fuel</th> <th>Nat Gas</th> <th>L.P.</th> <th>Oil</th> <th>Elec *</th> <th>Solid</th> <th>Solar</th> </tr> <tr> <td><input type="checkbox"/></td> <td><input type="checkbox"/></td> <td><input type="checkbox"/></td> <td><input type="checkbox"/></td> <td><input type="checkbox"/></td> <td><input type="checkbox"/></td> <td><input type="checkbox"/></td> </tr> </table> Space Htg <input type="checkbox"/> <input type="checkbox"/> <input type="checkbox"/> <input type="checkbox"/> <input type="checkbox"/> <input type="checkbox"/> Water Htg <input type="checkbox"/> <input type="checkbox"/> <input type="checkbox"/> <input type="checkbox"/> <input type="checkbox"/> <input type="checkbox"/>		Fuel	Nat Gas	L.P.	Oil	Elec *	Solid	Solar	<input type="checkbox"/>	<input type="checkbox"/>	<input type="checkbox"/>	<input type="checkbox"/>	<input type="checkbox"/>	<input type="checkbox"/>	<input type="checkbox"/>
Fuel	Nat Gas	L.P.	Oil	Elec *	Solid	Solar													
<input type="checkbox"/>	<input type="checkbox"/>	<input type="checkbox"/>	<input type="checkbox"/>	<input type="checkbox"/>	<input type="checkbox"/>	<input type="checkbox"/>													
* <input type="checkbox"/> Dwelling unit will have 3 kilowatt or more installed electric space heating equip Infiltration control option is: <input type="checkbox"/> Full sealing of joints <input type="checkbox"/> Blower door test. <input type="checkbox"/> Exterior air infiltration barrier.																			
13. HEAT LOSS (Calculated) Envelope _____ BTU/HR Infiltration _____ BTU/HR																			
14. EST. BUILDING COST \$ _____																			
The applicant agrees to comply with all applicable codes, statutes and ordinances and with the conditions of this permit; understands that the issuance of the permit creates no legal liability, express or implied, on the Department or municipality; and certifies that all the above information is accurate.																			
APPLICANT'S SIGNATURE _____			DATE SIGNED _____																
APPROVAL CONDITIONS This permit is issued pursuant to the following conditions. Failure to comply may result in suspension or revocation of this permit or other penalty.																			
_____ _____ _____ _____ _____ _____ _____ _____ _____																			
ISSUING JURISDICTION		<input type="checkbox"/> Town <input type="checkbox"/> Village <input type="checkbox"/> City <input type="checkbox"/> County <input type="checkbox"/> State of: _____		Municipality Number of Dwelling Location: _____															
FEES: Plan Review \$ _____ Inspection \$ _____ Wis Permit Seal \$ _____ Other \$ _____ Total \$ _____		PERMIT(S) ISSUED <input type="checkbox"/> Construction <input type="checkbox"/> HVAC <input type="checkbox"/> Electrical <input type="checkbox"/> Plumbing <input type="checkbox"/> Erosion		WIS. UNIFORM PERMIT SEAL NO. _____															
PERMIT ISSUED BY: Name _____ Date _____ Cert No. _____																			

Wisconsin Department of Industry,
Labor and Human Relations

**WISCONSIN ADMINISTRATIVE
BUILDING PERMIT APPLICATION**
(Wis. Stats. 101.63 (7) & 101.65 (3))

Safety and Buildings Division

Submit to non-enforcing municipalities for new 1- and 2- family dwellings.

SEE INSTRUCTIONS ON BACK OF YELLOW COPY.

The information you provide may be used by other government agency programs [Privacy Law, s. 15.04 (1) (m)].

PERMIT APPLICANT			
Last Name		First Name	Middle Initial
Street Address			
City	State	Zip Code	Telephone No. (include area code)
PROJECT LOCATION			
Building Address		Subdivision Name	Lot # Block #
Legal Description _____ 1/4, _____ 1/4, Section _____ T _____ N, R _____ E or W			Parcel No.
1. PROJECT TYPE		2. PROJECT HVAC EQUIPMENT	
<input type="checkbox"/> 1 Family	<input type="checkbox"/> Forced Air Furnace	<input type="checkbox"/> Radiant Baseboard or Panel (Elec.)	<input type="checkbox"/> Heat Pump
<input type="checkbox"/> 2 Family	<input type="checkbox"/> Boiler	<input type="checkbox"/> Central AC	<input type="checkbox"/> Other:
3. PROJECT ENERGY SOURCE		Nat. Gas	L.P.
Space Heating	<input type="checkbox"/>	<input type="checkbox"/>	<input type="checkbox"/>
Water Heating	<input type="checkbox"/>	<input type="checkbox"/>	<input type="checkbox"/>
		Oil	Elect.
		<input type="checkbox"/>	<input type="checkbox"/>
		Solid	Solar
		<input type="checkbox"/>	<input type="checkbox"/>
		<input type="checkbox"/>	<input type="checkbox"/>
4. PROJECT CONSTRUCTION TYPE		5. PROJECT FOUNDATION	
<input type="checkbox"/> Site Constructed	<input type="checkbox"/> Concrete	<input type="checkbox"/> Masonry	<input type="checkbox"/> Treated Wood
<input type="checkbox"/> Manufactured	<input type="checkbox"/> Other (specify):		
6. PROJECT AREA		7. ESTIMATED PROJECT BUILDING COST	
Living area = _____ Square Feet		\$ _____	
<p>I present that all the above information is correct, and understand that the issuance of this permit is for administrative purposes only. Onsite construction inspections will not and shall not be performed by the municipality which has not assumed jurisdiction per s. 101.65, Wis. Stats. I understand the Uniform Dwelling Code, Chapters ILHR 20-25, still applies to all new 1- and 2-family dwellings and must be complied with. I realize the issuance of this permit does not relieve me of compliance with other applicable codes and ordinances.</p>			
Applicant's Signature _____		Date Signed _____	
MUST BE COMPLETED BEFORE SUBMITTING TO DILHR:			
ISSUING JURISDICTION:	<input type="checkbox"/> Town <input type="checkbox"/> Village <input type="checkbox"/> City <input type="checkbox"/> County of:		
MUNICIPALITY NUMBER: # _____	Where Dwelling Located	FEES:	
PERMIT ISSUED BY:		DATE ISSUED:	

SH08 8754 (R 09/94)

White - Issuing Jurisdiction Pink - DILHR Within 30 Days Yellow - Applicant



ILHR 20-25 Appendix

Wisconsin Department of Industry,
Labor and Human Relations

Safety and Buildings Division
201 E. Washington Ave.
P.O. Box 7969
Madison, WI 53707
Telephone: (608) 266-3151

**Petition For Variance
Information & Instructions - ILHR 3**

In instances where exact compliance with a particular code requirement cannot be met or alternative designs are desired, the Division has a petition for variance program where it reviews and considers acceptance of alternatives which are not in strict conformance with the letter of the code, but which meet the intent of the code. A variance is not a waiver from a code requirement. The petitioner must provide an equivalency which meets the intent of the code section petitioned to obtain a variance. Documentation of the rationale for the equivalency is requested below. Failure to provide adequate information may delay your petition. Pictures, sketches, and plans may be submitted to support equivalency. If the proposed equivalency does not adequately safeguard the health, safety, and welfare of occupants, frequenters, firefighters, etc., the variance will be denied. NOTE: A SEPARATE PETITION IS REQUIRED FOR EACH BUILDING AND EACH CODE ISSUE PETITIONED (i.e., a window size issue cannot be processed on the same petition as a stair width issue). It should be noted that a petition for variance does not take the place of any required plan review submittal.

The Division is unable to process petitions for variance that are not properly completed. Before submitting the application, the following items should be checked for completeness in order to avoid delays:

- Petitioner's name (typed or printed)
- Petitioner's signature
The Petition For Variance Application must be signed by the owner of the building or project unless a power of attorney is submitted.
- Notary Public signature with affixed seal
- Analysis to establish equivalency, including any pictures, illustrations or sketches of the existing and proposed conditions to clearly convey your proposal to the reviewer.
- Proper fee
- Any required position statements by fire chief or municipal official

A position statement from the chief of the local fire department is required for fire safety issues. No position statement is required for nonfire topics such as sanitary, energy conservation and barrier free environments. For rules relating to one and two-family dwellings, only a position statement from the local enforcing municipality is required. Position statements must be completed and signed by the appropriate fire chief or municipal official. See the back of SBD-9890, Petition For Variance Application form for these position statement forms. Signatures or seals on all documents must be originals. Photocopies are not acceptable.

Contact numbers and fees for the Division's petition for variance program are as follows:

Chapters ILHR 20-25, Uniform Dwelling Code	(608) 267-5113	\$125.00
Chapters ILHR 67-68, Rental Unit Energy Efficiency Code	(608) 266-1930	\$125.00
Chapters ILHR 50-64, Commercial Building Code	(608) 267-9152	\$490.00
<ul style="list-style-type: none"> • The cities of Milwaukee and Madison may process petitions for variances from chapters ILHR 50 through 64 requirements on projects in their jurisdiction. 		
Chapter ILHR 70, Historic Building Code (608) 266-7849	(608) 266-7849	\$300.00
All other chapters		\$200.00
Boilers and Pressure Vessels	(608) 266-7548	
Electrical	(608) 266-5649	
Elevators	(608) 267-9606	
Flammable Liquids	(608) 266-1542	

Priority Review: Does not apply to Uniform Dwelling Code or Historic Building Code issues which already are treated as a priority. Double Above Amounts

Except for special cases, the Division will review and make a determination on a petition for variance within 30 business days of receipt of all calculations, documents, and fees required for the review. Uniform Dwelling Code petitions will be processed within 5 business days. Priority petitions will be processed within 10 business days.

Petitions for variance shall be submitted to:

DILHR Safety and Buildings
 201 East Washington Avenue
 P.O. Box 7969
 Madison, Wisconsin 53707

General Plumbing or Private Sewage petitions must be submitted on a different form. For information or to acquire the form call the Madison office, (608) 266-3815, or any of the other full-service offices identified below.

Hayward Office 209 W. First St. Hwy 63 Route 8 Box 8072 Hayward WI 54843 Telephone: (715) 634-4870 Fax: (715) 634-5150	La Crosse Office 2226 Rose St. La Crosse WI 54603 Telephone: (608) 785-9334 Fax: (608) 785-9330	Shawano Office 1053A E. Green Bay St. P.O. Box 434 Shawano WI 54166 Telephone: (715) 524-3626 Fax: (715) 524-3633	Waukesha Office 401 Pilot Ct., Suite C Waukesha WI 53188 Telephone: (414) 548-8606 Fax: (414) 548-8614
--	--	---	---

Wisconsin Department of Industry,
Labor and Human Relations

Safety & Buildings Division
201 E. Washington Ave.
P.O. Box 7969
Madison, WI 53707
Telephone: (608) 266-3151

Dept. Use Only
Plan No. _____
Amount Paid _____

Petition For Variance Application

Page 1 of _____

PLEASE TYPE OR PRINT CLEARLY - The information you provide may be used by other government agency programs [Privacy Law, s. 15.04(1)(m)].

1. Owner Information		2. Project Information		3. Designer Information	
Name		Building Occupancy Chapter(s) and Use		Designer	
Company Name		Tenant Name (if any)		Registration #	
Number and Street		Project Location (number and street)		Design Firm	
City, State and Zip Code		<input type="checkbox"/> City <input type="checkbox"/> Village <input type="checkbox"/> Township of		City, State and Zip Code	
Contact Person		County of		Contact Person	
Telephone Number ()	Fax Number ()	Prop. ID # (tax parcel # - contact county)		Telephone Number ()	Fax Number ()
4. Plan Review Status		<input type="checkbox"/> On hold <input type="checkbox"/> Already built <input type="checkbox"/> Preliminary design <input type="checkbox"/> Built according to older code but must be brought into compliance with current code <input type="checkbox"/> Approved, requesting revision <input type="checkbox"/> Plan will be submitted after petition determination <input type="checkbox"/> Submitted with petition <input type="checkbox"/> Other			
Review By: <input type="checkbox"/> State <input type="checkbox"/> Municipality		Plan Number _____			

- State the code section being petitioned and the specific condition or issue you are requesting be covered under this petition for variance. _____
- Reason why compliance with the code cannot be attained without the variance. _____
- State your proposed means and rationale of providing equivalent degree of health, safety, or welfare as addressed by the code section petitioned. _____
- List attachments to be considered as part of the petitioner's statements (i.e., model code sections, test reports, research articles, expert opinion, previously approved variances, pictures, plans, sketches, etc.) _____

Verification By Owner - Petition is valid only if notarized with affixed seal and accompanied by review fee (See Section ILHR 2.52 for complete fee information)

Note: Petitioner must be the owner of the building or project. Tenants, agents, designers, contractors, attorneys, etc., shall not sign petition unless Power of Attorney is submitted with the Petition for Variance Application.

_____, being duly sworn, I state as petitioner that I have read the foregoing petition and I believe it is true and that I have significant ownership rights to the subject building or project.

Petitioner's Name (type or print)	Subscribed and sworn to before me this date	Notary Public	My commission expires on
-----------------------------------	---	---------------	--------------------------

Complete Other Side

SBD-9890 (R 05/94)

Owner's Name	Project Location	Plan Number
--------------	------------------	-------------

Fire Department Position Statement

Page 2 of _____

To be completed for variances requested from ILHR 50-64, ILHR 10, and other fire related requirements

I have read the petition for variance and recommend: (check appropriate box)

- Approval Conditional Approval Denial No Comment

Explanation for recommendation including any conflicts with local rules and regulations and suggested conditions:

Fire Department Name and Address	
Fire Chief or Designee Name (type or print)	Telephone Number
Fire Chief or Designee Signature	Date Signed

Municipal Building Inspection Recommendation

To be completed for variances requested from ILHR 20-23, also to be used if ILHR 50-64 plan review is by municipality or orders are written on the building under construction; optional in other cases.

I have read the petition for variance and recommend: (check appropriate box)

- Approval Conditional Approval Denial No Comment

Explanation for recommendation including any conflicts with local rules and regulations and suggested conditions:

Municipality Exercising Jurisdiction	
Municipal Official's Name and Address (type or print)	Telephone Number
Municipal Enforcement Official's Signature	Date Signed

WISCONSIN ADMINISTRATIVE CODE

FASTENER SCHEDULE TABLE

Description of Building Materials/Connection	Number and Type of Fastener ^{1 2 3 4}
Joist to sill or girder, toe nail	2-16d, 3-8d
Bridging to joist, toe nail each end	2-8d
1" x 6" subfloor or less to each joist, face nail	2-8d or 2 staples, 1 1/2"
Wider than 1" x 6" subfloor to each joist, face nail	3-8d or 4 staples, 1 1/2"
2" subfloor to joist or girder, blind and face nail	2-16d
Sole plate to joist or blocking, face nail	16d at 16" o.c.
Top or sole plate to stud, end nail	2-16d
Stud to sole plate, toe nail	4-8d or 3-16d
Doubled studs, face nail	16d at 24" o.c.
Doubled top plates, face nail	16d at 16" o.c.
Top plates, laps and intersections, face nail	2-16d
Continuous header, two pieces	16d at 16" o.c. along each edge
Ceiling joists to plate, toe nail	2-16d, 3-8d
Continuous header to stud, toe nail	4-8d
Ceiling joist, laps over partitions, face nail	3-16d
Ceiling joist to parallel rafters, face nail	3-16d
Rafter to plate, toe nail	2-16d, 3-8d
1" brace to each stud and plate, face nail	2-8d or 2 staples, 1 1/2"
1" x 6" sheathing to each bearing, face nail	2-8d or 2 staples, 1 1/2"
1" x 8" sheathing to each bearing, face nail	2-8d or 3 staples, 1 1/2"
Wider than 1" x 8" sheathing to each bearing, face nail	3-8d or 4 staples, 1 1/2"
Built-up corner studs	16d at 30" o.c., 16d at 24" o.c.
Built-up girder and beams	20d at 32" o.c. at top and bottom and staggered 2-20d at ends and at each splice
2-inch planks	2-16d at each bearing
Roof rafters to ridge, valley or hip rafters, toe nail	4-16d
Roof rafters to ridge, valley or hip rafters, face nail	3-16d
Collar ties to rafters, face nail	3-8d
Plywood subfloor, roof and wall sheathing (to framing) ⁶	
1/4-inch to 5/16-inch	6d ⁵ or staple
1/4-inch to 3/8-inch	8d smooth or common, 6d deformed, or staple
3/8-inch to 1/2-inch	8d ⁵
1/2-inch to 1-inch	10d smooth or common, or 8d deformed
1 1/4-inch to 1 1/2-inch	
Fiberboard sheathing ⁷	
1/2-inch	6d common or staple, 1 1/2" long or roofing nail ¹¹
25/32-inch	8d common or staple, 1 1/2" long or roofing nail ¹¹
Gypsum sheathing, 3/8" ⁸	1 1/2" galvanized roofing nail, or 6d common, or staple
Particleboard wall sheathing (to framing) ⁶	
1/4-inch to 3/8-inch	6d common
3/8-inch to 1/2-inch	8d common or staple
Insulated sheathing	11-gauge roofing nails, 6d, 8d, or staple
Combination subfloor underlayment (to framing) ⁶	
1/4-inch and less	6d deformed
3/8-inch to 1-inch	8d deformed
1 1/4-inch to 1 1/2-inch	10d smooth ⁹ or common or 8d deformed ⁹
Panel siding (to framing) ¹⁰	
1/4-inch or less	6d
3/8-inch	8d

¹All nails are smooth-common, box or deformed shank except where otherwise stated.

²Nail is a general description and may be T-head, modified round head or round head.

³Staples are 16-gauge wire and have a minimum 7/16-inch o.d. crown width.

⁴Common or box nails may be used except where otherwise stated.

⁵Common or deformed shank.

⁶Nails spaced at 6 inches on center at edges, 12 inches at intermediate supports (10 inches at intermediate supports for floors), except 6 inches at all supports where spans are 48 inches or more.

⁷Nails spaced at 3 inches on center at edges, 6 inches at intermediate supports.

⁸Nails spaced at 4 inches on center at edges, 8 inches at intermediate supports.

⁹Nails spaced at 6 inches on center at edges and at intermediate supports.

¹⁰Corrosion-resistant siding and casing nails.

¹¹Galvanized roofing nails with 7/16-inch diameter head and 1 1/2-inch length for 3/8-inch sheathing and 1 1/2-inch for 25/32-inch sheathing.

Span Tables for Joists and Rafters

APPENDIX A
COMMENTARY

A.1 Floor Joists

stress must be less than the allowable bending design value, F_b , the allowable bending design value can be calculated as:

A.1.1 Floor Joists with L/360 Deflection Limitations

Tables F-1 through F-7 list spans for floor joists, used over a single span, with calculations based on modulus of elasticity, E , and the required bending design values, F_b , shown. Floor joist spans are determined based on a deflection limitation of L/360, where L is the span in inches. The deflection equation for a simple span beam with uniformly distributed load is:

$$F_b = \frac{wL^2}{8S} \quad [\text{Eq. A.1-4}]$$

$$\Delta_{\max} = \frac{5wL^4}{384EI} \quad [\text{Eq. A.1-1}]$$

Since $\Delta_{\max} \leq L/360$ this equation can be rewritten to solve for L as follows:

$$L = \sqrt[3]{\frac{384EI}{5w(360)}} \quad [\text{Eq. A.1-2}]$$

The uniform load, w , is based on the live load and joist spacing. The moment of inertia, I , is based on the joist size.

The required bending design value, F_b , is determined based on the calculated span. Note that the maximum moment, M_{\max} , of a single span beam with uniform load is calculated as:

$$M_{\max} = \frac{wL^2}{8} \quad [\text{Eq. A.1-3}]$$

where the uniform load, w , is based on the total dead plus live load and joist spacing. The actual bending stress in a beam is calculated as $f_b = M/S$ where S is the section modulus of the joist. The allowable bending design value, F_b , is based on a fully supported member, properly sheathed and nailed on the top edge of the joist. Since the actual

A.1.2 Floor Joists with L/480 or L/600 Deflection Limitations

Most codes require a minimum deflection limitation of L/360 for floor joists. In cases where a stricter deflection limit is desired, and the length shown is controlled by the L/360 deflection limit, the tabulated span lengths may be adjusted by the factors shown as follows:

Deflection Limit	Adjustment Factor
L/480	0.91
L/600	0.84

A.2 Ceiling Joists

Tables C-1 and C-2 list spans for ceiling joists used over a single span with calculations based on E and the required F_b values shown. The spans and required bending design values are determined from the same equations for a single span, uniformly

Span Tables for Joists and Rafters

loaded beam as shown above for single span floor joists. The only difference in design criteria is L/240 deflection limitations for ceiling joists supporting drywall ceilings which are typically required by building codes. The allowable bending design value, F_b , is based on a fully supported member, properly sheathed and nailed on one edge of the joist.

A.3 Rafters**A.3.1 Rafters with L/240 Deflection Limitations**

Tables R-1 through R-12 list spans for rafters with deflection limitations of L/240, used over a single span with calculations based on F_b values and the required E values shown. The allowable bending design value, F_b , is based on a fully supported member, properly sheathed and nailed on the top edge of the rafter. Generally, a deflection limitation of L/240 applies to rafters with a drywall ceiling attached to the underside (e.g., cathedral ceilings).

The maximum moment for a single span beam with a uniform load is defined above. This equation can be rewritten to solve for L as follows:

$$L = \sqrt{\frac{8 F_b S}{w}} \quad [\text{Eq. A.3.1-1}]$$

The uniform load, w , is based on the total dead plus live load and joist spacing.

The required modulus of elasticity, E, is determined based on this calculated span as follows:

$$E = \frac{5wL^3(240)}{384 I} \quad [\text{Eq. A.3.1-2}]$$

The uniform load, w , is based on the live load and joist spacing.

A.3.2 Rafters with L/180 Deflection Limitations

Tables R-13 through R-24 list spans for rafters with deflection limitations of L/180, used over a single span with calculations based on F_b values and the required E values shown. Calculations for span

and required modulus of elasticity are the same as those for single span beams with deflection limitations of L/240, except that 180 is substituted for 240 in the numerator of Equation A.3.1-2. Generally, a deflection limitation of L/180 applies to rafters without a drywall ceiling attached to the underside. Some governing building codes also consider the slope of the rafter in determining deflection limitations, and only allow L/180 deflection limitations for rafters with slopes greater than 3 in 12 and no ceiling attached.

A.3.3 Roof Loads

Section 6 outlines adjustment factors for determining rafter spans and required E values for roof live loads of 12 psf or 16 psf. The tabulated spans are modified by the square root of the ratio of the total uniform load at 20 psf and the total uniform load at the reduced level (12 or 16 psf). This is based on Equation A.3.1-1 which is used to calculate the span of a rafter based on the square root of the total uniform load.

The E values are adjusted based on the modified span as noted above and the uniform live load ratio. Based on Equation A.3.1-2:

$$\frac{E_2}{E_1} = \left(\frac{w_2}{w_1}\right) \left(\frac{L_2}{L_1}\right)^3 \quad [\text{Eq. A.3.3-1}]$$

$$= \left(\frac{LL_2}{LL_1}\right) \left(\frac{LL_1 + DL_1}{LL_2 + DL_2}\right)^{3/2} \quad [\text{Eq. A.3.3-2}]$$

where subscript 1 denotes variables associated with the 20 psf uniform live load and subscript 2 denotes variables associated with the uniform live load at the reduced level. LL is the uniform live load and DL is the uniform dead load. All other variables are as previously defined in A.3.

A.4 Compression Perpendicular to Grain Design Requirements

Compression perpendicular to grain is also a design consideration for joists and rafters. Required compression perpendicular to grain design values

Span Tables for Joists and Rafters

are tabulated in Table 9.1. These values are calculated assuming a bearing width of 1.5", a total load of 66.67 plf, and the calculated span. The 66.67 plf total load is based on a 40 psf live load and 10 psf dead load on joists at 16" on center, which is a typical condition of use. Alternate F_{c1} values are possible by adjusting the tabulated values in direct proportion to the desired load. Adjustment factors for various loads and spacings are tabulated in Table 9.2 for convenience. Required compression design values perpendicular to grain are also applicable to bearing plates.

A.5 Lumber Design Values

The spans for nominal 2x5 joists or rafters are 82 percent of the spans tabulated for the same spacing of nominal 2x6 joists or rafters. For each joist or rafter spacing, the values of E for 2x5's are the same as the tabulated E values for 2x6's. The values of F_b for 2x5's shall be determined by multiplying the tabulated F_b values for 2x6's by 1.077.

A.6 Load Requirements

Applicable design criteria for each condition of use appear at the top of each table. While these criteria are directed principally to residential construction they are suitable for other occupancies having similar conditions of loading. Examples include, but are not limited to, assembly areas with fixed seats, cornices, fire escapes for single family residential buildings, cell blocks of penal institutions, multiple family dwelling units and hotel guest rooms. Check governing building code requirements for other applicable occupancies. Tabulated spans for rafters also apply to other types of occupancy, since the occupancy has little bearing on roof loading.

A.7 Support Requirements

Adequate support shall be provided for all joists and rafters. Ridge beams shall be installed at roof peaks, and rafters shall bear directly on the ridge beam or be supported by hangers or framing anchors. Ceiling joists shall not be required when properly designed ridge beams are used.

A ridge board shall be permitted to be substituted for a ridge beam when the roof slope equals or exceeds 3 in 12, except that ridge beams shall be required for cathedral ceilings. Ridge boards shall be at least 1 inch nominal in thickness and not less than the depth of the cut end of the rafter. Rafters shall be placed directly opposite each other, and ceiling joists shall be installed parallel with rafters to provide a continuous tie between exterior walls.

A.8 Repetitive Member Use

Repetitive member use is that condition where framing members such as joists, rafters, studs, planks, decking or similar members are in contact or spaced not more than 24 inches on-center, are not less than 3 in number and are joined by floor, roof or other load-distributing elements adequate to support the design load. Bending design values (F_b) for such use are 15 percent greater than for single-member use. Table W-1 of *Design Values for Joists and Rafters*, a supplement to these tables, provide bending design values for repetitive member use of joists and rafters.

A.9 Load Duration

For joists and rafters, bending design values (F_b) are adjusted for load duration by the following factors:

- 1.00 for 10 years (normal) duration, as for occupancy live load,
- 1.15 for 2 months duration, as for snow,
- 1.25 for 7 days duration, as for construction loading.

FLOOR JOISTS WITH L/360 DEFLECTION LIMITATIONS

Table No.	Live Load (psf)	Dead ¹ Load (psf)	Material or Occupancy
F-2	40	10	Decks and all rooms except those used for sleeping areas and attic floors

1. Dead load includes the weight of the framing members

CEILING JOISTS WITH L/240 DEFLECTION LIMITATIONS

Table No.	Live Load (psf)	Dead ¹ Load (psf)	Material or Occupancy
C-1	10	5	Drywall ceiling attached no attic storage
C-2	20	10	Drywall ceiling attached, limited attic storage where development of future rooms is not possible

1. Dead load includes the weight of the framing members

**RAFTERS WITH L/240 DEFLECTION LIMITATIONS
(Drywall ceiling attached to underside of rafter)**

Table No.	Live Load (psf)	Dead ¹ Load (psf)	Material or Occupancy
R-2	30	10	Light roof (up to 2 courses of asphalt shingles, or wood shakes/shingles)
R-3	40	10	Light roof (up to 2 courses of asphalt shingles, or wood shakes/shingles)
R-10	30	20	Heavy roof covering (3" clay book tile)
R-11	40	20	Heavy roof covering (3" clay book tile)

1. Dead load includes the weight of the framing members

**RAFTERS WITH L/180 DEFLECTION LIMITATIONS
(No drywall ceiling attached to underside of rafter)**

Table No.	Live Load (psf)	Dead ¹ Load (psf)	Material or Occupancy
R-14	30	10	Light roof (up to 2 courses of asphalt shingles, or wood shakes/shingles)
R-15	40	10	Light roof (up to 2 courses of asphalt shingles, or wood shakes/shingles)
R-22	30	20	Heavy roof covering (3" clay book tile)
R-23	40	20	Heavy roof covering (3" clay book tile)

1. Dead load includes the weight of the framing members

Span Tables for Joists and Rafters

TABLE F-2
FLOOR JOISTS WITH L/360 DEFLECTION LIMITS

DESIGN CRITERIA:
Deflection - For 40 psf live load.
Limited to span in inches divided by 360.
Strength - Live load of 40 psf plus dead load of 10 psf determines the required bending design value.

Joist Size (in)	Spacing (in)	Modulus of Elasticity, E, in 1,000,000 psi																
		0.8	0.9	1.0	1.1	1.2	1.3	1.4	1.5	1.6	1.7	1.8	1.9	2.0	2.1	2.2	2.3	2.4
2x6	12.0	8-6	8-10	9-2	9-6	9-9	10-0	10-3	10-6	10-9	10-11	11-2	11-4	11-7	11-9	11-11	12-1	12-3
	16.0	7-9	8-0	8-4	8-7	8-10	9-1	9-4	9-6	9-9	9-11	10-2	10-4	10-6	10-8	10-10	11-0	11-2
	19.2	7-3	7-7	7-10	8-1	8-4	8-7	8-9	9-0	9-2	9-4	9-6	9-8	9-10	10-0	10-2	10-4	10-6
	24.0	6-9	7-0	7-3	7-6	7-9	7-11	8-2	8-4	8-6	8-8	8-10	9-0	9-2	9-4	9-6	9-7	9-9
2x8	12.0	11-3	11-8	12-1	12-6	12-10	13-2	13-6	13-10	14-2	14-5	14-8	15-0	15-3	15-6	15-9	15-11	16-2
	16.0	10-2	10-7	11-0	11-4	11-8	12-0	12-3	12-7	12-10	13-1	13-4	13-7	13-10	14-1	14-3	14-6	14-8
	19.2	9-7	10-0	10-4	10-8	11-0	11-3	11-7	11-10	12-1	12-4	12-7	12-10	13-0	13-3	13-5	13-8	13-10
	24.0	8-11	9-3	9-7	9-11	10-2	10-6	10-9	11-0	11-3	11-5	11-8	11-11	12-1	12-3	12-6	12-8	12-10
2x10	12.0	14-4	14-11	15-5	15-11	16-5	16-10	17-3	17-8	18-0	18-5	18-9	19-1	19-5	19-9	20-1	20-4	20-8
	16.0	13-0	13-6	14-0	14-6	14-11	15-3	15-8	16-0	16-5	16-9	17-0	17-4	17-8	17-11	18-3	18-6	18-9
	19.2	12-3	12-9	13-2	13-7	14-0	14-5	14-9	15-1	15-5	15-9	16-0	16-4	16-7	16-11	17-2	17-5	17-8
	24.0	11-4	11-10	12-3	12-8	13-0	13-4	13-8	14-0	14-4	14-7	14-11	15-2	15-5	15-8	15-11	16-2	16-5
2x12	12.0	17-5	18-1	18-9	19-4	19-11	20-6	21-0	21-6	21-11	22-5	22-10	23-3	23-7	24-0	24-5	24-9	25-1
	16.0	15-10	16-5	17-0	17-7	18-1	18-7	19-1	19-6	19-11	20-4	20-9	21-1	21-6	21-10	22-2	22-6	22-10
	19.2	14-11	15-6	16-0	16-7	17-0	17-6	17-11	18-4	18-9	19-2	19-6	19-10	20-2	20-6	20-10	21-2	21-6
	24.0	13-10	14-4	14-11	15-4	15-10	16-3	16-8	17-0	17-5	17-9	18-1	18-5	18-9	19-1	19-4	19-8	19-11
F _b	12.0	718	777	833	888	941	993	1043	1092	1140	1187	1233	1278	1323	1367	1410	1452	1494
	16.0	790	855	917	977	1036	1093	1148	1202	1255	1306	1357	1407	1456	1504	1551	1598	1644
	19.2	840	909	975	1039	1101	1161	1220	1277	1333	1388	1442	1495	1547	1598	1649	1698	1747
	24.0	905	979	1050	1119	1186	1251	1314	1376	1436	1496	1554	1611	1667	1722	1776	1829	1882

Note: The required bending design value, F_b, in pounds per square inch is shown at the bottom of each table and is applicable to all lumber sizes shown. Spans are shown in feet-inches and are limited to 26' and less. Check sources of supply for availability of lumber in lengths greater than 20'.

Span Tables for Joists and Rafters

TABLE C-1
CEILING JOISTS WITH L/240 DEFLECTION LIMITS

DESIGN CRITERIA:

Deflection - For 10 psf live load.
Limited to span in inches divided by 240.
Strength - Live Load of 10 psf plus
dead load of 5 psf determines the required fiber stress value.

Joist Size (in)	Spacing (in)	Modulus of Elasticity, E, in 1,000,000 psi																			
		0.8	0.9	1.0	1.1	1.2	1.3	1.4	1.5	1.6	1.7	1.8	1.9	2.0	2.1	2.2	2.3	2.4			
2x4	12.0	9-10	10-3	10-7	10-11	11-3	11-7	11-10	12-2	12-5	12-8	12-11	13-2	13-4	13-7	13-9	14-0	14-2			
	16.0	8-11	9-4	9-8	9-11	10-3	10-6	10-9	11-0	11-3	11-6	11-9	11-11	12-2	12-4	12-6	12-9	12-11			
	19.2	8-5	8-9	9-1	9-4	9-8	9-11	10-2	10-4	10-7	10-10	11-0	11-3	11-5	11-7	11-9	12-0	12-2			
	24.0	7-10	8-1	8-5	8-8	8-11	9-2	9-5	9-8	9-10	10-0	10-3	10-5	10-7	10-9	10-11	11-1	11-3			
2x6	12.0	15-6	16-1	16-8	17-2	17-8	18-2	18-8	19-1	19-6	19-11	20-3	20-8	21-0	21-4	21-8	22-0	22-4			
	16.0	14-1	14-7	15-2	15-7	16-1	16-6	16-11	17-4	17-8	18-1	18-5	18-9	19-1	19-5	19-8	20-0	20-3			
	19.2	13-3	13-9	14-3	14-8	15-2	15-7	15-11	16-4	16-8	17-0	17-4	17-8	17-11	18-3	18-6	18-10	19-1			
	24.0	12-3	12-9	13-3	13-8	14-1	14-5	14-9	15-2	15-6	15-9	16-1	16-4	16-8	16-11	17-2	17-5	17-8			
2x8	12.0	20-5	21-2	21-11	22-8	23-4	24-0	24-7	25-2	25-8	26-3	26-10	27-4	28-1	28-8	29-4	30-1	30-8			
	16.0	18-6	19-3	19-11	20-7	21-2	21-9	22-4	22-10	23-4	23-10	24-3	24-8	25-2	25-7	25-11	26-4	26-9			
	19.2	17-5	18-1	18-9	19-5	19-11	20-6	21-0	21-6	21-11	22-5	22-10	23-3	23-8	24-0	24-5	24-9	25-2			
	24.0	16-2	16-10	17-5	18-0	18-6	19-0	19-6	19-11	20-5	20-10	21-2	21-7	21-11	22-4	22-8	23-0	23-4			
2x10	12.0	26-0	27-0	28-0	29-0	30-0	31-0	32-0	33-0	34-0	35-0	36-0	37-0	38-0	39-0	40-0	41-0	42-0			
	16.0	23-8	24-7	25-5	26-4	27-3	28-2	29-1	29-10	30-0	30-9	31-8	32-7	33-6	34-5	35-4	36-3	37-2			
	19.2	22-3	23-1	23-11	24-9	25-5	26-3	27-1	27-10	28-0	28-9	29-8	30-7	31-6	32-5	33-4	34-3	35-2			
	24.0	20-8	21-6	22-3	22-11	23-8	24-3	24-10	25-5	26-0	26-7	27-2	27-9	28-4	29-1	29-8	30-5	31-2			
F _v	12.0	711	769	825	880	932	983	1033	1082	1129	1176	1221	1266	1310	1354	1396	1438	1480			
	16.0	783	847	909	968	1026	1082	1137	1191	1243	1294	1344	1394	1442	1490	1537	1583	1629			
	19.2	832	900	965	1029	1090	1150	1208	1265	1321	1375	1429	1481	1533	1583	1633	1682	1731			
	24.0	896	969	1040	1108	1174	1239	1302	1363	1423	1481	1539	1595	1651	1706	1759	1812	1864			

Note: The required bending design value, F_b, in pounds per square inch is shown at the bottom of each table and is applicable to all lumber sizes shown. Spans are shown in feet-inches and are limited to 26' and less. Check sources of supply for availability of lumber in lengths greater than 20'.

Span Tables for Joists and Rafters

TABLE C-2
CEILING JOISTS WITH L/240 DEFLECTION LIMITS

DESIGN CRITERIA:
Deflection - For 20 psf live load.
Limited to span in inches divided by 240.
Strength - Live Load of 20 psf plus dead load of 10 psf determines the required bending design value.

Joist Size (in)	Spacing (in)	Modulus of Elasticity, E, in 1,000,000 psi																
		0.8	0.9	1.0	1.1	1.2	1.3	1.4	1.5	1.6	1.7	1.8	1.9	2.0	2.1	2.2	2.3	2.4
2x4	12.0	7-10	8-1	8-5	8-8	8-11	9-2	9-5	9-8	9-10	10-0	10-3	10-5	10-7	10-9	10-11	11-1	11-3
	16.0	7-1	7-5	7-8	7-11	8-1	8-4	8-7	8-9	8-11	9-1	9-4	9-6	9-8	9-9	9-11	10-1	10-3
	19.2	6-8	6-11	7-2	7-5	7-8	7-10	8-1	8-3	8-5	8-7	8-9	8-11	9-1	9-3	9-4	9-6	9-8
	24.0	6-2	6-5	6-8	6-11	7-1	7-3	7-6	7-8	7-10	8-0	8-1	8-3	8-5	8-7	8-8	8-10	8-11
2x6	12.0	12-3	12-9	13-3	13-8	14-1	14-5	14-9	15-2	15-6	15-9	16-1	16-4	16-8	16-11	17-2	17-5	17-8
	16.0	11-2	11-7	12-0	12-5	12-9	13-1	13-5	13-9	14-1	14-4	14-7	14-11	15-2	15-5	15-7	15-10	16-1
	19.2	10-6	10-11	11-4	11-8	12-0	12-4	12-8	12-11	13-3	13-6	13-9	14-0	14-3	14-6	14-8	14-11	15-2
	24.0	9-9	10-2	10-6	10-10	11-2	11-5	11-9	12-0	12-3	12-6	12-9	13-0	13-3	13-5	13-8	13-10	14-1
2x8	12.0	16-2	16-10	17-5	18-0	18-6	19-0	19-6	19-11	20-5	20-10	21-2	21-7	21-11	22-4	22-8	23-0	23-4
	16.0	14-8	15-3	15-10	16-4	16-10	17-3	17-9	18-1	18-6	18-11	19-3	19-7	19-11	20-3	20-7	20-11	21-2
	19.2	13-10	14-5	14-11	15-5	15-10	16-3	16-8	17-1	17-5	17-9	18-1	18-5	18-9	19-1	19-5	19-8	19-11
	24.0	12-10	13-4	13-10	14-3	14-8	15-1	15-6	15-10	16-2	16-6	16-10	17-2	17-5	17-9	18-0	18-3	18-6
2x10	12.0	20-8	21-6	22-3	22-11	23-8	24-3	24-10	25-5	26-0								
	16.0	18-9	19-6	20-2	20-10	21-6	22-1	22-7	23-1	23-8	24-1	24-7	25-0	25-5	25-10	24-4	24-9	25-5
	19.2	17-8	18-4	19-0	19-7	20-2	20-9	21-3	21-9	22-3	22-8	23-1	23-7	23-11	22-7	22-11	23-4	23-8
	24.0	16-5	17-0	17-8	18-3	18-9	19-3	19-9	20-2	20-8	21-1	21-6	21-10	22-3	22-7	22-11	23-4	23-8
F _b	12.0	896	969	1040	1108	1174	1239	1302	1363	1423	1481	1539	1595	1651	1706	1759	1812	1864
	16.0	986	1067	1145	1220	1293	1364	1433	1500	1566	1631	1694	1756	1817	1877	1936	1995	2052
	19.2	1048	1134	1216	1296	1374	1449	1522	1594	1664	1733	1800	1866	1931	1995	2058	2120	2181
	24.0	1129	1221	1310	1396	1480	1561	1640	1717	1793	1866	1939	2010	2080	2149	2217	2283	2349

Note: The required bending design value, F_b, in pounds per square inch is shown at the bottom of each table and is applicable to all lumber sizes shown. Spans are shown in feet-inches and are limited to 26' and less. Check sources of supply for availability of lumber in lengths greater than 20'.

Span Tables for Joists and Rafters

TABLE R-2
RAFTERS WITH L/240 DEFLECTION LIMITATION

DESIGN CRITERIA:
Strength - Live Load of 30 psf plus
Dead Load of 10 psf determines the required bending design value.
Deflection - For 30 psf live load.
Limited to span in inches divided by 240.

Rafter Size (in)	Spacing (in)	Bending Design Value, F _b , (psi)																					
		300	400	500	600	700	800	900	1000	1100	1200	1300	1400	1500	1600	1700	1800	1900	2000	2100	2200	2300	2400
2x6	12.0	6-2	7-1	7-11	8-8	9-5	10-0	10-8	11-3	11-9	12-4	12-10	13-3	13-9	14-2	14-8	15-1	15-6	15-11				
	16.0	5-4	6-2	6-10	7-6	8-2	8-8	9-3	9-9	10-2	10-8	11-1	11-6	11-11	12-4	12-8	13-1	13-5	13-9	14-1	14-5		
	19.2	4-10	5-7	6-3	6-10	7-5	7-11	8-5	8-11	9-4	9-9	10-1	10-6	10-10	11-3	11-7	11-11	12-3	12-7	12-10	13-2	13-6	
	24.0	4-4	5-0	5-7	6-2	6-8	7-1	7-6	7-11	8-4	8-8	9-1	9-5	9-9	10-0	10-4	10-8	10-11	11-3	11-6	11-9	12-0	12-4
2x8	12.0	8-1	9-4	10-6	11-6	12-5	13-3	14-0	14-10	15-6	16-3	16-10	17-6	18-1	18-9	19-4	19-10	20-5	20-11				
	16.0	7-0	8-1	9-1	10-9	11-6	12-2	12-10	13-5	14-0	14-7	15-2	15-8	16-3	16-9	17-2	17-8	18-1	18-7	19-0			
	19.2	6-5	7-5	8-3	9-1	9-9	10-6	11-1	11-8	12-3	12-10	13-4	13-10	14-4	14-10	15-3	15-8	16-2	16-7	16-11	17-4	17-9	
	24.0	5-9	6-7	7-5	8-1	8-9	9-4	9-11	10-6	11-0	11-6	11-11	12-5	12-10	13-3	13-8	14-0	14-5	14-10	15-2	15-6	15-10	16-3
2x10	12.0	10-4	11-11	13-4	14-8	15-10	16-11	17-11	18-11	19-10	20-8	21-6	22-4	23-1	23-11	24-7	25-4	26-0					
	16.0	8-11	10-4	11-7	12-8	13-8	14-8	15-6	16-4	17-2	17-11	18-8	19-4	20-0	20-8	21-4	21-11	22-6	23-1	23-8	24-3		
	19.2	8-2	9-5	10-7	11-7	12-6	13-4	14-2	14-11	15-8	16-4	17-0	17-8	18-3	18-11	19-6	20-0	20-7	21-1	21-8	22-2	22-8	
	24.0	7-4	8-5	9-5	10-4	11-2	11-11	12-8	13-4	14-0	14-8	15-3	15-10	16-4	16-11	17-5	17-11	18-5	18-11	19-4	19-10	20-3	20-8
2x12	12.0	12-7	14-6	16-3	17-9	19-3	20-6	21-9	23-0	24-1	25-2												
	16.0	10-11	12-7	14-1	15-5	16-8	17-9	18-10	19-11	20-10	21-9	22-8	23-6	24-4	25-2	25-11							
	19.2	9-11	11-6	12-10	14-1	15-2	16-3	17-3	18-2	19-0	19-11	20-8	21-6	22-3	23-0	23-8	24-4	25-0	25-8				
	24.0	8-11	10-3	11-6	12-7	13-7	14-6	15-5	16-3	17-0	17-9	18-6	19-3	19-11	20-6	21-2	21-9	22-5	23-0	23-6	24-1	24-8	25-2
E	12.0	0.15	0.23	0.32	0.43	0.54	0.66	0.78	0.92	1.06	1.21	1.36	1.52	1.69	1.86	2.04	2.22	2.41	2.60				
	16.0	0.13	0.20	0.28	0.37	0.47	0.57	0.68	0.80	0.92	1.05	1.18	1.32	1.46	1.61	1.76	1.92	2.08	2.25	2.42	2.60		
	19.2	0.12	0.18	0.26	0.34	0.43	0.52	0.62	0.73	0.84	0.95	1.08	1.20	1.33	1.47	1.61	1.75	1.90	2.05	2.21	2.37	2.53	
	24.0	0.11	0.16	0.23	0.30	0.38	0.46	0.55	0.65	0.75	0.85	0.96	1.08	1.19	1.31	1.44	1.57	1.70	1.84	1.98	2.12	2.27	2.41

Note: The required modulus of elasticity, E, in 1,000,000 pounds per square inch is shown at the bottom of each table, is limited to 2.6 million psi and less, and is applicable to all lumber sizes shown. Spans are shown in feet-inches and are limited to 26' and less. Check sources of supply for availability of lumber in lengths greater than 20'.

Span Tables for Joists and Rafters

TABLE R-3
RAFTERS WITH L/240 DEFLECTION LIMITATION

DESIGN CRITERIA:
Strength - Live Load of 40 psf plus
Dead Load of 10 psf determines the required bending design value.
Deflection - For 40 psf live load.
Limited to span in inches divided by 240.

Rafter Size (in)	Spacing (in)	Bending Design Value, F _b , (psi)																						
		300	400	500	600	700	800	900	1000	1100	1200	1300	1400	1500	1600	1700	1800	1900	2000	2100	2200	2300	2400	
2x6	12.0	5-6	6-4	7-1	7-9	8-5	9-0	9-6	10-0	10-6	11-0	11-5	11-11	12-4	12-8	13-1	13-6	13-10	14-2					
	16.0	4-9	5-6	6-2	6-9	7-3	7-9	8-3	8-8	9-1	9-6	9-11	10-3	10-8	11-0	11-4	11-8	12-0	12-4	12-7	12-11			
	19.2	4-4	5-0	5-7	6-2	6-8	7-1	7-6	7-11	8-4	8-8	9-1	9-5	9-9	10-0	10-4	10-8	10-11	11-3	11-6	11-9	12-0	12-4	
	24.0	3-11	4-6	5-0	5-6	5-11	6-4	6-9	7-1	7-5	7-9	8-1	8-5	8-8	9-0	9-3	9-6	9-9	10-0	10-3	10-6	10-9	11-0	
2x8	12.0	7-3	8-4	9-4	10-3	11-1	11-10	12-7	13-3	13-11	14-6	15-1	15-8	16-3	16-9	17-3	17-9	18-3	18-9					
	16.0	6-3	7-3	8-1	8-11	9-7	10-3	10-10	11-6	12-0	12-7	13-1	13-7	14-0	14-6	14-11	15-5	15-10	16-3	16-7	17-0			
	19.2	5-9	6-7	7-5	8-1	8-9	9-4	9-11	10-6	11-0	11-6	11-11	12-5	12-10	13-3	13-8	14-0	14-5	14-10	15-2	15-6	15-10	16-3	
	24.0	5-2	5-11	6-7	7-3	7-10	8-4	8-11	9-4	9-10	10-3	10-8	11-1	11-6	11-10	12-2	12-7	12-11	13-3	13-7	13-11	14-2	14-6	
2x10	12.0	9-3	10-8	11-11	13-1	14-2	15-1	16-0	16-11	17-9	18-6	19-3	20-0	20-8	21-4	22-0	22-8	23-3	23-11					
	16.0	8-0	9-3	10-4	11-4	12-3	13-1	13-10	14-8	15-4	16-0	16-8	17-4	17-11	18-6	19-1	19-7	20-2	20-8	21-2	21-8			
	19.2	7-4	8-5	9-5	10-4	11-2	11-11	12-8	13-4	14-0	14-8	15-3	15-10	16-4	16-11	17-5	17-11	18-5	18-11	19-4	19-10	20-3	20-8	
	24.0	6-6	7-7	8-5	9-3	10-0	10-8	11-4	11-11	12-6	13-1	13-7	14-2	14-8	15-1	15-7	16-0	16-6	16-11	17-4	17-9	18-1	18-6	
2x12	12.0	11-3	13-0	14-6	15-11	17-2	18-4	19-6	20-6	21-7	22-6	23-5	24-4	25-2	26-0									
	16.0	9-9	11-3	12-7	13-9	14-11	15-11	16-10	17-9	18-8	19-6	20-3	21-1	21-9	22-6	23-2	23-10	24-6	25-2	25-9				
	19.2	8-11	10-3	11-6	12-7	13-7	14-6	15-5	16-3	17-0	17-9	18-6	19-3	19-11	20-6	21-2	21-9	22-5	23-0	23-6	24-1	24-8	25-2	
	24.0	7-11	9-2	10-3	11-3	12-2	13-0	13-9	14-6	15-3	15-11	16-7	17-2	17-9	18-4	18-11	19-6	20-0	20-6	21-1	21-7	22-0	22-6	
E	12.0	0.14	0.22	0.31	0.41	0.51	0.63	0.75	0.88	1.01	1.15	1.30	1.45	1.61	1.77	1.94	2.12	2.30	2.48					
	16.0	0.12	0.19	0.27	0.35	0.44	0.54	0.65	0.76	0.88	1.00	1.12	1.26	1.39	1.54	1.68	1.83	1.99	2.15	2.31	2.48			
	19.2	0.11	0.18	0.24	0.32	0.41	0.50	0.59	0.69	0.80	0.91	1.03	1.15	1.27	1.40	1.54	1.67	1.81	1.96	2.11	2.26	2.42	2.58	
	24.0	0.10	0.16	0.22	0.29	0.36	0.44	0.53	0.62	0.71	0.81	0.92	1.03	1.14	1.25	1.37	1.50	1.62	1.75	1.89	2.02	2.16	2.30	

Note: The required modulus of elasticity, E, in 1,000,000 pounds per square inch is shown at the bottom of each table, is limited to 2.6 million psi and less, and is applicable to all lumber sizes shown. Spans are shown in feet-inches and are limited to 26' and less. Check sources of supply for availability of lumber in lengths greater than 20'.

Span Tables for Joists and Rafters

TABLE R-10
RAFTERS WITH L/240 DEFLECTION LIMITATION

DESIGN CRITERIA:
Strength - Live Load of 30 psf plus
Dead Load of 20 psf determines the required bending design value.
Deflection - For 30 psf live load.
Limited to span in inches divided by 240.

Rafter Size (in)	Spacing (in)	Bending Design Value, F_b , (psi)																								
		300	400	500	600	700	800	900	1000	1100	1200	1300	1400	1500	1600	1700	1800	1900	2000	2100	2200	2300	2400	2500	2600	2700
2x6	12.0	5-6	6-4	7-1	7-9	8-5	9-0	9-6	10-0	10-6	11-0	11-5	11-11	12-4	12-8	13-1	13-6	13-10	14-2	14-7	14-11	15-3	15-7	15-11		
	16.0	4-9	5-6	6-2	6-9	7-3	7-9	8-3	8-8	9-1	9-6	9-11	10-3	10-8	11-0	11-4	11-8	12-0	12-4	12-7	12-11	13-2	13-6	13-9	14-0	14-3
	19.2	4-4	5-0	5-7	6-2	6-8	7-1	7-6	7-11	8-4	8-8	9-1	9-5	9-9	10-0	10-4	10-8	10-11	11-3	11-6	11-9	12-0	12-4	12-7	12-10	13-1
2x8	12.0	7-3	8-4	9-4	10-3	11-1	11-10	12-7	13-3	13-11	14-6	15-1	15-8	16-3	16-9	17-3	17-9	18-3	18-9	19-2	19-8	20-1	20-6	20-11		
	16.0	6-3	7-3	8-1	8-11	9-7	10-3	10-10	11-6	12-0	12-7	13-1	13-7	14-0	14-6	14-11	15-5	15-10	16-3	16-7	17-0	17-5	17-9	18-1	18-6	18-10
	19.2	5-9	6-7	7-5	8-1	8-9	9-4	9-11	10-6	11-0	11-6	11-11	12-5	12-10	13-3	13-8	14-0	14-5	14-10	15-2	15-6	15-10	16-3	16-7	16-10	17-2
2x10	12.0	5-2	5-11	6-7	7-3	7-10	8-4	8-11	9-4	9-10	10-3	10-8	11-1	11-6	11-10	12-2	12-7	12-11	13-3	13-7	13-11	14-2	14-6	14-10	15-1	15-5
	16.0	9-3	10-8	11-11	13-1	14-2	15-1	16-0	16-11	17-9	18-6	19-3	20-0	20-8	21-4	22-0	22-8	23-3	23-11	24-6	25-1	25-7				
	19.2	8-0	9-3	10-4	11-4	12-3	13-4	14-0	14-8	15-4	16-0	16-8	17-4	17-11	18-6	19-1	19-7	20-2	20-8	21-2	21-8	22-2	22-8	23-1	23-7	24-0
2x12	12.0	6-6	7-7	8-5	9-3	10-0	10-8	11-4	11-11	12-6	13-1	13-7	14-2	14-8	15-1	15-7	16-0	16-6	16-11	17-4	17-9	18-1	18-6	18-11	19-3	19-7
	16.0	11-3	13-0	14-6	15-11	17-2	18-4	19-6	20-6	21-7	22-6	23-5	24-4	25-2	26-0											
	19.2	9-9	11-3	12-7	13-9	14-11	15-11	16-10	17-9	18-8	19-6	20-3	21-1	21-9	22-6	23-2	23-10	24-6	25-2	25-9						
E	12.0	0.11	0.17	0.23	0.31	0.38	0.47	0.56	0.66	0.76	0.86	0.97	1.09	1.21	1.33	1.46	1.59	1.72	1.86	2.00	2.14	2.29	2.44	2.60		
	16.0	0.09	0.14	0.20	0.26	0.33	0.41	0.49	0.57	0.66	0.75	0.84	0.94	1.05	1.15	1.26	1.37	1.49	1.61	1.73	1.86	1.99	2.12	2.25	2.39	2.53
	19.2	0.09	0.13	0.18	0.24	0.30	0.37	0.44	0.52	0.60	0.68	0.77	0.86	0.95	1.05	1.15	1.25	1.36	1.47	1.58	1.70	1.81	1.93	2.05	2.18	2.31
24.0	0.08	0.12	0.16	0.22	0.27	0.33	0.40	0.46	0.54	0.61	0.69	0.77	0.85	0.94	1.03	1.12	1.22	1.31	1.41	1.52	1.62	1.73	1.84	1.95	2.06	

Note: The required modulus of elasticity, E, in 1,000,000 pounds per square inch is shown at the bottom of each table, is limited to 2.6 million psi and less, and is applicable to all lumber sizes shown. Spans are shown in feet-inches and are limited to 26' and less. Check sources of supply for availability of lumber in lengths greater than 20'.

Span Tables for Joists and Rafters

		Bending Design Value, F_b , (psi)																											
		200	300	400	500	600	700	800	900	1000	1100	1200	1300	1400	1500	1600	1700	1800	1900	2000	2100	2200	2300	2400	2500	2600	2700	2800	2900
<p>DESIGN CRITERIA: Strength - Live Load of 30 psf plus Dead Load of 10 psf determines the required bending design value. Deflection - For 30 psf live load. Limited to span in inches divided by 180.</p>																													
Rafter Size (in)	Spacing (in)																												
2x4	12.0	3-2	3-11	4-6	5-1	5-6	6-0	6-5	6-9	7-2	7-6	7-10	8-2	8-5	8-9	9-0	9-4	9-7	9-10	10-1	10-4	10-7	10-10	11-1					
	16.0	2-9	3-5	3-11	4-4	4-10	5-2	5-6	5-10	6-2	6-6	6-9	7-1	7-4	7-7	7-10	8-1	8-4	8-6	8-9	9-0	9-2	9-5	9-7	9-9	10-0			
	19.2	2-6	3-1	3-7	4-0	4-4	4-9	5-1	5-4	5-8	5-11	6-2	6-5	6-8	6-11	7-2	7-4	7-7	7-9	8-0	8-2	8-5	8-7	8-9	8-11	9-1	9-3	9-5	
	24.0	2-3	2-9	3-2	3-7	3-11	4-3	4-6	4-10	5-1	5-4	5-6	5-9	6-0	6-2	6-5	6-7	6-9	7-0	7-2	7-4	7-6	7-8	7-10	8-0	8-2	8-4	8-5	8-7
2x6	12.0	5-0	6-2	7-1	7-11	8-8	9-5	10-0	10-8	11-3	11-9	12-4	12-10	13-3	13-9	14-2	14-8	15-1	15-6	15-11	16-3	16-8	17-0	17-5					
	16.0	4-4	5-4	6-2	6-10	7-6	8-2	8-8	9-3	9-9	10-2	10-8	11-1	11-6	11-11	12-4	12-8	13-1	13-5	13-9	14-1	14-5	14-9	15-1	15-4	15-8			
	19.2	4-0	4-10	5-7	6-3	6-10	7-5	7-11	8-5	8-11	9-4	9-9	10-1	10-6	10-10	11-3	11-7	11-11	12-3	12-7	12-10	13-2	13-6	13-9	14-0	14-4	14-7	14-10	
24.0	3-7	4-4	5-0	5-7	6-2	6-8	7-1	7-6	7-11	8-4	8-8	9-1	9-5	9-9	10-0	10-4	10-8	10-11	11-3	11-6	11-9	12-0	12-4	12-7	12-10	13-1	13-3	13-6	13-9
2x8	12.0	6-7	8-1	9-4	10-6	11-6	12-5	13-3	14-0	14-10	15-6	16-3	16-10	17-6	18-1	18-9	19-4	19-10	20-5	20-11	21-5	21-11	22-5	22-11					
	16.0	5-9	7-0	8-1	9-1	10-9	11-6	12-2	12-10	13-5	14-0	14-7	15-2	15-8	16-3	16-9	17-2	17-8	18-1	18-7	19-0	19-5	19-10	20-3	20-8				
	19.2	5-3	6-5	7-5	8-3	9-1	9-9	10-6	11-1	11-8	12-3	12-10	13-4	13-10	14-4	14-10	15-3	15-8	16-2	16-7	16-11	17-4	17-9	18-1	18-6	18-10	19-3	19-7	
	24.0	4-8	5-9	6-7	7-5	8-1	8-9	9-4	9-11	10-6	11-0	11-6	11-11	12-5	12-10	13-3	13-8	14-0	14-5	14-10	15-2	15-6	15-10	16-3	16-7	16-10	17-2	17-6	17-10
2x10	12.0	8-5	10-4	11-11	13-4	14-8	15-10	16-11	17-11	18-11	19-10	20-8	21-6	22-4	23-1	23-11	24-7	25-4	26-0										
	16.0	7-4	8-11	10-4	11-7	12-8	13-8	14-8	15-6	16-4	17-2	17-11	18-8	19-4	20-0	20-8	21-4	21-11	22-6	23-1	23-8	24-3	24-10	25-4	25-10				
	19.2	6-8	8-2	9-5	10-7	11-7	12-6	13-4	14-2	14-11	15-8	16-4	17-0	17-8	18-3	18-11	19-6	20-0	20-7	21-1	21-8	22-2	22-8	23-1	23-7	24-1	24-6	25-0	
	24.0	6-0	7-4	8-5	9-5	10-4	11-2	11-11	12-8	13-4	14-0	14-8	15-3	15-10	16-4	16-11	17-5	17-11	18-5	18-11	19-4	19-10	20-3	20-8	21-1	21-6	21-11	22-4	22-9
E	12.0	0.06	0.11	0.17	0.24	0.32	0.40	0.49	0.59	0.69	0.79	0.91	1.02	1.14	1.27	1.39	1.53	1.66	1.80	1.95	2.10	2.25	2.40	2.56					
	16.0	0.05	0.10	0.15	0.21	0.28	0.35	0.43	0.51	0.60	0.69	0.78	0.88	0.99	1.10	1.21	1.32	1.44	1.56	1.69	1.82	1.95	2.08	2.22	2.36	2.50			
	19.2	0.05	0.09	0.14	0.19	0.25	0.32	0.39	0.47	0.54	0.63	0.72	0.81	0.90	1.00	1.10	1.21	1.32	1.43	1.54	1.66	1.78	1.90	2.03	2.15	2.28	2.42	2.55	
	24.0	0.04	0.08	0.12	0.17	0.23	0.29	0.35	0.42	0.49	0.56	0.64	0.72	0.81	0.89	0.99	1.08	1.18	1.28	1.38	1.48	1.59	1.70	1.81	1.93	2.04	2.16	2.28	2.41
Note:		The required modulus of elasticity, E , in 1,000,000 pounds per square inch is shown at the bottom of each table, is limited to 2,6 million psi and less, and is applicable to all lumber sizes shown. Spans are shown in feet-inches and are limited to 26' and less. Check sources of supply for availability of lumber in lengths greater than 20'.																											

Span Tables for Joists and Rafters

TABLE R-15
RAFTERS WITH L/180 DEFLECTION LIMITATION

DESIGN CRITERIA:
Strength - Live Load of 40 psf plus
Dead Load of 10 psf determines the required bending design value.
Deflection - For 40 psf live load.
Limited to span in inches divided by 180.

Rafter Size (in)	Spacing (in)	Bending Design Value, F _b (psi)																											
		200	300	400	500	600	700	800	900	1000	1100	1200	1300	1400	1500	1600	1700	1800	1900	2000	2100	2200	2300	2400	2500	2600	2700	2800	2900
2x4	12.0	2-10	3-6	4-0	4-6	4-11	5-4	5-9	6-1	6-5	6-8	7-0	7-3	7-7	7-10	8-1	8-4	8-7	8-10	9-0	9-3	9-6	9-8	9-11	10-1	8-11	9-1		
	16.0	2-6	3-0	3-6	3-11	4-3	4-8	4-11	5-3	5-6	5-10	6-1	6-4	6-7	6-9	7-0	7-3	7-5	7-8	7-10	8-0	8-2	8-5	8-7	8-9	8-2	8-4	8-5	8-7
	19.2	2-3	2-9	3-2	3-7	3-11	4-3	4-6	4-10	5-1	5-4	5-6	5-9	6-0	6-2	6-5	6-7	6-9	7-0	7-2	7-4	7-6	7-8	7-10	8-0	8-2	8-4	8-5	8-7
	24.0	2-0	2-6	2-10	3-2	3-6	3-9	4-0	4-3	4-6	4-9	4-11	5-2	5-4	5-6	5-9	5-11	6-1	6-3	6-5	6-7	6-8	6-10	7-0	7-2	7-3	7-5	7-7	7-8
2x6	12.0	4-6	5-6	6-4	7-1	7-9	8-5	9-0	9-6	10-0	10-6	11-0	11-5	11-11	12-4	12-8	13-1	13-6	13-10	14-2	14-7	14-11	15-3	15-7	15-11	14-0	14-3		
	16.0	3-11	4-9	5-6	6-2	6-9	7-3	7-9	8-3	8-8	9-1	9-6	9-11	10-3	10-8	11-0	11-4	11-8	12-0	12-4	12-7	12-11	13-2	13-6	13-9	12-10	13-1	13-3	13-6
	19.2	3-7	4-4	5-0	5-7	6-2	6-8	7-1	7-6	7-11	8-4	8-8	9-1	9-5	9-9	10-0	10-4	10-8	10-11	11-3	11-6	11-9	12-0	12-4	12-7	12-10	13-1	13-3	13-6
	24.0	3-2	3-11	4-6	5-0	5-6	5-11	6-4	6-9	7-1	7-5	7-9	8-1	8-5	8-8	9-0	9-3	9-6	9-9	10-0	10-3	10-6	10-9	11-0	11-3	11-5	11-8	11-11	12-1
2x8	12.0	5-11	7-3	8-4	9-4	10-3	11-1	11-10	12-7	13-3	13-11	14-6	15-1	15-8	16-3	16-9	17-3	17-9	18-3	18-9	19-2	19-8	20-1	20-6	20-11	18-1	18-6	18-10	
	16.0	5-2	6-3	7-3	8-1	8-11	9-7	10-3	10-10	11-6	12-0	12-7	13-1	13-7	14-0	14-6	14-11	15-5	15-10	16-3	16-7	17-0	17-5	17-9	18-1	18-6	18-10		
	19.2	4-8	5-9	6-7	7-5	8-1	8-9	9-4	9-11	10-6	11-0	11-6	11-11	12-5	12-10	13-3	13-8	14-0	14-5	14-10	15-2	15-6	15-10	16-3	16-7	16-10	17-2	17-6	17-10
	24.0	4-2	5-2	5-11	6-7	7-3	7-10	8-4	8-11	9-4	9-10	10-3	10-8	11-1	11-6	11-10	12-2	12-7	12-11	13-3	13-7	13-11	14-2	14-6	14-10	15-1	15-5	15-8	15-11
2x10	12.0	7-7	9-3	10-8	11-11	13-1	14-2	15-1	16-0	16-11	17-9	18-6	19-3	20-0	20-8	21-4	22-0	22-8	23-3	23-11	24-6	25-1	25-7	23-1	23-7	24-0			
	16.0	6-6	8-0	9-3	10-4	11-4	12-3	13-1	13-10	14-8	15-4	16-0	16-8	17-4	17-11	18-6	19-1	19-7	20-2	20-8	21-2	21-8	22-2	22-8	23-1	23-7	24-0		
	19.2	6-0	7-4	8-5	9-5	10-4	11-2	11-11	12-8	13-4	14-0	14-8	15-3	15-10	16-4	16-11	17-5	17-11	18-5	18-11	19-4	19-10	20-3	20-8	21-1	21-6	21-11	22-4	22-9
	24.0	5-4	6-6	7-7	8-5	9-3	10-0	10-8	11-4	11-11	12-6	13-1	13-7	14-2	14-8	15-1	15-7	16-0	16-6	16-11	17-4	17-9	18-1	18-6	18-11	19-3	19-7	20-0	20-4
E	12.0	0.06	0.11	0.17	0.23	0.31	0.38	0.47	0.56	0.66	0.76	0.86	0.97	1.09	1.21	1.33	1.46	1.59	1.72	1.86	2.00	2.14	2.29	2.44	2.60	2.75	2.91	3.07	3.23
	16.0	0.05	0.09	0.14	0.20	0.26	0.33	0.41	0.49	0.57	0.66	0.75	0.84	0.94	1.05	1.15	1.26	1.37	1.49	1.61	1.73	1.86	1.99	2.12	2.25	2.39	2.53		
	19.2	0.05	0.09	0.13	0.18	0.24	0.30	0.37	0.44	0.52	0.60	0.68	0.77	0.86	0.95	1.05	1.15	1.25	1.36	1.47	1.58	1.70	1.81	1.93	2.05	2.18	2.31	2.43	2.57
	24.0	0.04	0.08	0.12	0.16	0.22	0.27	0.33	0.40	0.46	0.54	0.61	0.69	0.77	0.85	0.94	1.03	1.12	1.22	1.31	1.41	1.52	1.62	1.73	1.84	1.95	2.06	2.18	2.30

Note: The required modulus of elasticity, E, in 1,000,000 pounds per square inch is shown at the bottom of each table, is limited to 2.6 million psi and less, and is applicable to all lumber sizes shown. Spans are shown in feet-inches and are limited to 26' and less. Check sources of supply for availability of lumber in lengths greater than 20'.

Span Tables for Joists and Rafters

TABLE R-22
RAFTERS WITH L/180 DEFLECTION LIMITATION

DESIGN CRITERIA:

Strength - Live Load of 30 psf plus Dead Load of 20 psf determines the required bending design value.
Deflection - For 30 psf live load. Limited to span in inches divided by 180.

Rafter Size (in)	Spacing (in)	Bending Design Value, F_b (psi)																												
		200	300	400	500	600	700	800	900	1000	1100	1200	1300	1400	1500	1600	1700	1800	1900	2000	2100	2200	2300	2400	2500	2600	2700	2800	2900	3000
2x4	12.0	2-10	3-6	4-0	4-6	4-11	5-4	5-9	6-1	6-5	6-8	7-0	7-3	7-7	7-10	8-1	8-4	8-7	8-10	9-0	9-3	9-6	9-8	9-11	10-1	10-4	10-6	10-8	10-11	11-1
	16.0	2-6	3-0	3-6	3-11	4-3	4-8	4-11	5-3	5-6	5-10	6-1	6-4	6-7	6-9	7-0	7-3	7-5	7-8	7-10	8-0	8-2	8-5	8-7	8-9	8-11	9-1	9-3	9-5	9-7
	19.2	2-3	2-9	3-2	3-7	3-11	4-3	4-6	4-10	5-1	5-4	5-6	5-9	6-0	6-2	6-5	6-7	6-9	7-0	7-2	7-4	7-6	7-8	7-10	8-0	8-2	8-4	8-5	8-7	8-9
	24.0	2-0	2-6	2-10	3-2	3-6	3-9	4-0	4-3	4-6	4-9	4-11	5-2	5-4	5-6	5-9	5-11	6-1	6-3	6-5	6-7	6-8	6-10	7-0	7-2	7-3	7-5	7-7	7-8	7-10
2x6	12.0	4-6	5-6	6-4	7-1	7-9	8-5	9-0	9-6	10-0	10-6	11-0	11-5	11-11	12-4	12-8	13-1	13-6	13-10	14-2	14-7	14-11	15-3	15-7	15-11	16-2	16-6	16-10	17-1	17-5
	16.0	3-11	4-9	5-6	6-2	6-9	7-3	7-9	8-3	8-8	9-1	9-6	9-11	10-3	10-8	11-0	11-4	11-8	12-0	12-4	12-7	12-11	13-2	13-6	13-9	14-0	14-3	14-7	14-10	15-1
	19.2	3-7	4-4	5-0	5-7	6-2	6-8	7-1	7-6	7-11	8-4	8-8	9-1	9-5	9-9	10-0	10-4	10-8	10-11	11-3	11-6	11-9	12-0	12-4	12-7	12-10	13-1	13-3	13-6	13-9
	24.0	3-2	3-11	4-6	5-0	5-6	5-11	6-4	6-9	7-1	7-5	7-9	8-1	8-5	8-8	9-0	9-3	9-6	9-9	10-0	10-3	10-6	10-9	11-0	11-3	11-5	11-8	11-11	12-1	12-4
2x8	12.0	5-11	7-3	8-4	9-4	10-3	11-1	11-10	12-7	13-3	13-11	14-6	15-1	15-8	16-3	16-9	17-3	17-9	18-3	18-9	19-2	19-8	20-1	20-6	20-11	21-4	21-9	22-2	22-6	22-11
	16.0	5-2	6-3	7-3	8-1	8-11	9-7	10-3	10-10	11-6	12-0	12-7	13-1	13-7	14-0	14-6	14-11	15-5	15-10	16-3	16-7	17-0	17-5	17-9	18-1	18-6	18-10	19-2	19-6	19-10
	19.2	4-8	5-9	6-7	7-5	8-1	8-9	9-4	9-11	10-6	11-0	11-6	11-11	12-5	12-10	13-3	13-8	14-0	14-5	14-10	15-2	15-6	15-10	16-3	16-7	16-10	17-2	17-6	17-10	18-1
	24.0	4-2	5-2	5-11	6-7	7-3	7-10	8-4	8-11	9-4	9-10	10-3	10-8	11-1	11-6	11-10	12-2	12-7	12-11	13-3	13-7	13-11	14-2	14-6	14-10	15-1	15-5	15-8	15-11	16-3
2x10	12.0	7-7	9-3	10-8	11-11	13-1	14-2	15-1	16-0	16-11	17-9	18-6	19-3	20-0	20-8	21-4	22-0	22-8	23-3	23-11	24-6	25-1	25-7							
	16.0	6-6	8-0	9-3	10-4	11-4	12-3	13-1	13-10	14-8	15-4	16-0	16-8	17-4	17-11	18-6	19-1	19-7	20-2	20-8	21-2	21-8	22-2	22-8	23-1	23-7	24-0	24-6	24-11	25-4
	19.2	6-0	7-4	8-5	9-5	10-4	11-2	11-11	12-8	13-4	14-0	14-8	15-3	15-10	16-4	16-11	17-5	17-11	18-5	18-11	19-4	19-10	20-3	20-8	21-1	21-6	21-11	22-4	22-9	23-1
	24.0	5-4	6-6	7-7	8-5	9-3	10-0	10-8	11-4	11-11	12-6	13-1	13-7	14-2	14-8	15-1	15-7	16-0	16-6	16-11	17-4	17-9	18-1	18-6	18-11	19-3	19-7	20-0	20-4	20-8
E	12.0	0.04	0.08	0.12	0.17	0.23	0.29	0.35	0.42	0.49	0.57	0.65	0.73	0.82	0.91	1.00	1.09	1.19	1.29	1.39	1.50	1.61	1.72	1.83	1.95	2.07	2.19	2.31	2.43	2.56
	16.0	0.04	0.07	0.11	0.15	0.20	0.25	0.31	0.36	0.43	0.49	0.56	0.63	0.71	0.78	0.86	0.95	1.03	1.12	1.21	1.30	1.39	1.49	1.59	1.69	1.79	1.89	2.00	2.11	2.22
	19.2	0.03	0.06	0.10	0.14	0.18	0.23	0.28	0.33	0.39	0.45	0.51	0.58	0.65	0.72	0.79	0.86	0.94	1.02	1.10	1.19	1.27	1.36	1.45	1.54	1.63	1.73	1.83	1.92	2.03
	24.0	0.03	0.06	0.09	0.12	0.16	0.20	0.25	0.30	0.35	0.40	0.46	0.52	0.58	0.64	0.71	0.77	0.84	0.91	0.99	1.06	1.14	1.22	1.30	1.38	1.46	1.55	1.63	1.72	1.81

Note: The required modulus of elasticity, E , in 1,000,000 pounds per square inch is shown at the bottom of each table, is limited to 2.6 million psi and less, and is applicable to all lumber sizes shown. Spans are shown in feet-inches and are limited to 26' and less. Check sources of supply for availability of lumber in lengths greater than 20'.

Span Tables for Joists and Rafters

TABLE R-23
RAFTERS WITH L/180 DEFLECTION LIMITATION

DESIGN CRITERIA:
Strength - Live Load of 40 psf plus
Dead Load of 20 psf determines the required bending design value.
Deflection - For 40 psf live load.
Limited to span in inches divided by 180.

Rafters Size (in)	Spacing (in)	Bending Design Value, F_b , (psi)																												
		200	300	400	500	600	700	800	900	1000	1100	1200	1300	1400	1500	1600	1700	1800	1900	2000	2100	2200	2300	2400	2500	2600	2700	2800	2900	3000
2x4	12.0	2-7	3-2	3-8	4-1	4-6	4-11	5-3	5-6	5-10	6-1	6-5	6-8	6-11	7-2	7-5	7-7	7-10	8-0	8-3	8-5	8-8	8-10	9-0	9-3	9-5	9-7	9-9	9-11	10-1
	16.0	2-3	2-9	3-2	3-7	3-11	4-3	4-6	4-10	5-1	5-4	5-6	5-9	6-0	6-2	6-5	6-7	6-9	7-0	7-2	7-4	7-6	7-8	7-10	8-0	8-2	8-4	8-5	8-7	8-9
	19.2	2-1	2-6	2-11	3-3	3-7	3-10	4-1	4-4	4-7	4-10	5-1	5-3	5-5	5-8	5-10	6-0	6-2	6-4	6-6	6-8	6-10	7-0	7-2	7-3	7-5	7-7	7-9	7-10	8-0
	24.0	1-10	2-3	2-7	2-11	3-2	3-5	3-8	3-11	4-1	4-4	4-6	4-8	4-11	5-1	5-3	5-5	5-6	5-8	5-10	6-0	6-1	6-3	6-5	6-6	6-8	6-9	6-11	7-0	7-2
2x6	12.0	4-1	5-0	5-10	6-6	7-1	7-8	8-2	8-8	9-2	9-7	10-0	10-5	10-10	11-3	11-7	11-11	12-4	12-8	13-0	13-3	13-7	13-11	14-2	14-6	14-9	15-1	15-4	15-7	15-11
	16.0	3-7	4-4	5-0	5-7	6-2	6-8	7-1	7-6	7-11	8-4	8-8	9-1	9-5	9-9	10-0	10-4	10-8	10-11	11-3	11-6	11-9	12-0	12-4	12-7	12-10	13-1	13-3	13-6	13-9
	19.2	3-3	4-0	4-7	5-1	5-7	6-1	6-6	6-10	7-3	7-7	7-11	8-3	8-7	8-11	9-2	9-5	9-9	10-0	10-3	10-6	10-9	11-0	11-3	11-5	11-8	11-11	12-2	12-4	12-7
	24.0	2-11	3-7	4-1	4-7	5-0	5-5	5-10	6-2	6-6	6-10	7-1	7-5	7-8	7-11	8-2	8-5	8-8	8-11	9-2	9-5	9-7	9-10	10-0	10-3	10-5	10-8	10-10	11-0	11-3
2x8	12.0	5-5	6-7	7-8	8-7	9-4	10-1	10-10	11-6	12-1	12-8	13-3	13-9	14-4	14-10	15-3	15-9	16-3	16-8	17-1	17-6	17-11	18-4	18-9	19-1	19-6	19-10	20-3	20-7	20-11
	16.0	4-8	5-9	6-7	7-5	8-1	8-9	9-4	9-11	10-6	11-0	11-6	11-11	12-5	12-10	13-3	13-8	14-0	14-5	14-10	15-2	15-6	15-10	16-3	16-7	16-10	17-2	17-6	17-10	18-1
	19.2	4-3	5-3	6-0	6-9	7-5	8-0	8-7	9-1	9-7	10-0	10-6	10-11	11-4	11-8	12-1	12-5	12-10	13-2	13-6	13-10	14-2	14-6	14-10	15-1	15-5	15-8	16-0	16-3	16-7
	24.0	3-10	4-8	5-5	6-0	6-7	7-2	7-8	8-1	8-7	9-0	9-4	9-9	10-1	10-6	10-10	11-2	11-6	11-9	12-1	12-5	12-8	12-11	13-3	13-6	13-9	14-0	14-4	14-7	14-10
2x10	12.0	6-11	8-5	9-9	10-11	11-11	12-11	13-9	14-8	15-5	16-2	16-11	17-7	18-3	18-11	19-6	20-1	20-8	21-3	21-10	22-4	22-10	23-5	23-11	24-5	24-10	25-4	25-10		
	16.0	6-0	7-4	8-5	9-5	10-4	11-2	11-11	12-8	13-4	14-0	14-8	15-3	15-10	16-4	16-11	17-5	17-11	18-5	18-11	19-4	19-10	20-3	20-8	21-1	21-6	21-11	22-4	22-9	23-1
	19.2	5-5	6-8	7-8	8-7	9-5	10-2	10-11	11-7	12-2	12-9	13-4	13-11	14-5	14-11	15-5	15-11	16-4	16-10	17-3	17-8	18-1	18-6	18-11	19-3	19-8	20-0	20-5	20-9	21-1
	24.0	4-11	6-0	6-11	7-8	8-5	9-1	9-9	10-4	10-11	11-5	11-11	12-5	12-11	13-4	13-9	14-3	14-8	15-0	15-5	15-10	16-2	16-6	16-11	17-3	17-7	17-11	18-3	18-7	18-11
E	12.0	0.04	0.08	0.13	0.18	0.23	0.29	0.36	0.43	0.50	0.58	0.66	0.74	0.83	0.92	1.01	1.11	1.21	1.31	1.41	1.52	1.63	1.74	1.86	1.98	2.10	2.22	2.34	2.47	2.60
	16.0	0.04	0.07	0.11	0.15	0.20	0.25	0.31	0.37	0.43	0.50	0.57	0.64	0.72	0.80	0.88	0.96	1.05	1.13	1.22	1.32	1.41	1.51	1.61	1.71	1.82	1.92	2.03	2.14	2.25
	19.2	0.04	0.06	0.10	0.14	0.18	0.23	0.28	0.34	0.40	0.46	0.52	0.59	0.65	0.73	0.80	0.88	0.95	1.04	1.12	1.20	1.29	1.38	1.47	1.56	1.66	1.75	1.85	1.95	2.05
	24.0	0.03	0.06	0.09	0.13	0.16	0.21	0.25	0.30	0.35	0.41	0.46	0.52	0.59	0.65	0.72	0.78	0.85	0.93	1.00	1.08	1.15	1.23	1.31	1.40	1.48	1.57	1.66	1.75	1.84

Note: The required modulus of elasticity, E , in 1,000,000 pounds per square inch is shown at the bottom of each table, is limited to 2.6 million psi and less, and is applicable to all lumber sizes shown. Spans are shown in feet-inches and are limited to 26' and less. Check sources of supply for availability of lumber in lengths greater than 20'.

ILHR 20-25 Appendix

Table W-1 Design Values for Joists and Rafters - Visually Graded Lumber

Species or Species Combination	Species That May Be Included in Combination
Aspen	Big Tooth Aspen, Quaking Aspen
Beech-Birch-Hickory	American Beech, Bitternut Hickory, Mockernut Hickory, Nutmeg Hickory, Pecan Hickory, Pignut Hickory, Shagbark Hickory, Shellbark Hickory, Sweet Birch, Water Hickory, Yellow Birch
Cottonwood	
Douglas Fir-Larch	Douglas Fir, Western Larch
Douglas Fir-Larch (North)	Douglas Fir, Western Larch
Douglas Fir-South	
Eastern Hemlock-Tamarack	Eastern Hemlock, Tamarack
Eastern Softwoods	Balsam Fir, Black Spruce, Eastern Hemlock, Eastern White Pine, Jack Pine, Norway (Red) Pine, Pitch Pine, Red Spruce, Tamarack, White Spruce
Eastern White Pine	
Hem-Fir	California Red Fir, Grand Fir, Noble Fir, Pacific Silver Fir, Western Hemlock, White Fir
Hem-Fir (North)	Amabilis Fir, Western Hemlock
Mixed Maple	Black Maple, Red Maple, Silver Maple, Sugar Maple
Mixed Oak	All Oak Species graded under NELMA rules
Mixed Southern Pine	Any species in the Southern Pine species combination, plus either or both of the following: Virginia Pine, Pond Pine
Northern Red Oak	Black Oak, Northern Red Oak, Pin Oak, Scarlet Oak
Northern Species	All softwood species graded under NLGA rules
Northern White Cedar	
Red Maple	
Red Oak	Black Oak, Cherrybark Oak, Laurel Oak, Northern Red Oak, Pin Oak, Scarlet Oak, Southern Red Oak, Water Oak, Willow Oak
Redwood	
Southern Pine	Loblolly Pine, Longleaf Pine, Shortleaf Pine, Slash Pine
Spruce-Pine-Fir	Alpine Fir, Balsam Fir, Black Spruce, Engelmann Spruce, Jack Pine, Lodgepole Pine, Red Spruce, White Spruce
Spruce-Pine-Fir (South)	Balsam Fir, Black Spruce, Engelmann Spruce, Jack Pine, Lodgepole Pine, Norway (Red) Pine, Red Spruce, Sitka Spruce, White Spruce
Western Cedars	Alaska Cedar, Incense Cedar, Port Orford Cedar, Western Red Cedar
Western Woods	Any species in the Douglas Fir-Larch, Douglas Fir-South, Hem-Fir, and Spruce-Pine-Fir (South) species combinations, plus any or all of the following: Alpine Fir, Idaho White Pine, Mountain Hemlock, Ponderosa Pine, Sugar Pine
White Oak	Bur Oak, Chestnut Oak, Live Oak, Overcup Oak, Post Oak, Swamp Chestnut Oak, Swamp White Oak, White Oak
Yellow Poplar	

TABLE W-1 DESIGN VALUES FOR JOISTS AND RAFTERS - VISUALLY GRADED LUMBER

These "F_b" values are for use where repetitive members are spaced not more than 24 inches. For wider spacing, the "F_b" values shall be reduced 13%.

Values for surfaced dry or surfaced green lumber apply at 19% maximum moisture content in use.

Species and Grade	Size	Design Value in Bending "F _b "			Modulus of Elasticity "E"	Grading Rules Agency
		Normal Duration	Snow Loading	7-Day Loading		
COTTONWOOD						
Select Structural	2x4	1510	1735	1885	1,200,000	NSLB
No.1		1080	1240	1350	1,200,000	
No.2		1080	1240	1350	1,100,000	
No.3		605	695	755	1,000,000	
Stud		600	690	750	1,000,000	
Construction		805	925	1005	1,000,000	
Standard		460	530	575	900,000	
Utility		200	230	250	900,000	
Select Structural	2x6	1310	1505	1635	1,200,000	
No.1		935	1075	1170	1,200,000	
No.2		935	1075	1170	1,100,000	
No.3		525	600	655	1,000,000	
Stud	545	630	685	1,000,000		
Select Structural	2x8	1210	1390	1510	1,200,000	
No.1		865	990	1080	1,200,000	
No.2		865	990	1080	1,100,000	
No.3	485	555	605	1,000,000		
Select Structural	2x10	1105	1275	1385	1,200,000	
No.1		790	910	990	1,200,000	
No.2		790	910	990	1,100,000	
No.3	445	510	555	1,000,000		
Select Structural	2x12	1005	1155	1260	1,200,000	
No.1		720	825	900	1,200,000	
No.2		720	825	900	1,100,000	
No.3		405	465	505	1,000,000	
DOUGLAS FIR-LARCH						
Select Structural	2x4	2500	2875	3125	1,900,000	WCLIB WWPA
No.1 & Btr		1985	2280	2480	1,800,000	
No.1		1725	1985	2155	1,700,000	
No.2		1510	1735	1885	1,600,000	
No.3		865	990	1080	1,400,000	
Stud		855	980	1065	1,400,000	
Construction		1150	1325	1440	1,500,000	
Standard		635	725	790	1,400,000	
Utility		315	365	395	1,300,000	
Select Structural		2x6	2170	2495	2710	
No.1 & Btr	1720		1975	2150	1,800,000	
No.1	1495		1720	1870	1,700,000	
No.2	1310		1505	1635	1,600,000	
No.3	750		860	935	1,400,000	
Stud	775	895	970	1,400,000		
Select Structural	2x8	2000	2300	2500	1,900,000	
No.1 & Btr		1585	1825	1985	1,800,000	
No.1		1380	1585	1725	1,700,000	
No.2		1210	1390	1510	1,600,000	
No.3	690	795	865	1,400,000		
Select Structural	2x10	1835	2110	2295	1,900,000	
No.1 & Btr		1455	1675	1820	1,800,000	
No.1		1265	1455	1580	1,700,000	
No.2		1105	1275	1385	1,600,000	
No.3	635	725	790	1,400,000		
Select Structural	2x12	1670	1920	2085	1,900,000	
No.1 & Btr		1325	1520	1655	1,800,000	
No.1		1150	1325	1440	1,700,000	
No.2		1005	1155	1260	1,600,000	
No.3	575	660	720	1,400,000		

TABLE W-1 DESIGN VALUES FOR JOISTS AND RAFTERS - VISUALLY GRADED LUMBER

These "F_b" values are for use where repetitive members are spaced not more than 24 inches. For wider spacing, the "F_b" values shall be reduced 13%.
 Values for surfaced dry or surfaced green lumber apply at 19% maximum moisture content in use.

Species and Grade	Size	Design Value in Bending "F _b "			Modulus of Elasticity "E"	Grading Rules Agency
		Normal Duration	Snow Loading	7-Day Loading		
DOUGLAS FIR-LARCH (NORTH)						
Select Structural	2x4	2245	2580	2805	1,900,000	NLGA
No.1/No.2		1425	1635	1780	1,600,000	
No.3		820	940	1025	1,400,000	
Stud		820	945	1030	1,400,000	
Construction		1095	1255	1365	1,500,000	
Standard		605	695	755	1,400,000	
Utility		290	330	360	1,300,000	
Select Structural	2x6	1945	2235	2430	1,900,000	
No.1/No.2		1235	1420	1540	1,600,000	
No.3		710	815	890	1,400,000	
Stud		750	860	935	1,400,000	
Select Structural	2x8	1795	2065	2245	1,900,000	
No.1/No.2		1140	1310	1425	1,600,000	
No.3		655	755	820	1,400,000	
Select Structural	2x10	1645	1890	2055	1,900,000	
No.1/No.2		1045	1200	1305	1,600,000	
No.3		600	690	750	1,400,000	
Select Structural	2x12	1495	1720	1870	1,900,000	
No.1/No.2		950	1090	1185	1,600,000	
No.3		545	630	685	1,400,000	
DOUGLAS FIR-SOUTH						
Select Structural	2x4	2245	2580	2805	1,400,000	WWPA
No.1		1555	1785	1940	1,300,000	
No.2		1425	1635	1780	1,200,000	
No.3		820	940	1025	1,100,000	
Stud		820	945	1030	1,100,000	
Construction		1065	1225	1330	1,200,000	
Standard		605	695	755	1,100,000	
Utility	290	330	360	1,000,000		
Select Structural	2x6	1945	2235	2430	1,400,000	
No.1		1345	1545	1680	1,300,000	
No.2		1235	1420	1540	1,200,000	
No.3		710	815	890	1,100,000	
Stud	750	860	935	1,100,000		
Select Structural	2x8	1795	2065	2245	1,400,000	
No.1		1240	1430	1555	1,300,000	
No.2		1140	1310	1425	1,200,000	
No.3	655	755	820	1,100,000		
Select Structural	2x10	1645	1890	2055	1,400,000	
No.1		1140	1310	1425	1,300,000	
No.2		1045	1200	1305	1,200,000	
No.3	600	690	750	1,100,000		
Select Structural	2x12	1495	1720	1870	1,400,000	
No.1		1035	1190	1295	1,300,000	
No.2		950	1090	1185	1,200,000	
No.3	545	630	685	1,100,000		

TABLE W-1 DESIGN VALUES FOR JOISTS AND RAFTERS - VISUALLY GRADED LUMBER

These "F_b" values are for use where repetitive members are spaced not more than 24 inches. For wider spacing, the "F_b" values shall be reduced 13%.

Values for surfaced dry or surfaced green lumber apply at 19% maximum moisture content in use.

Species and Grade	Size	Design Value in Bending "F _b "			Modulus of Elasticity "E"	Grading Rules Agency
		Normal Duration	Snow Loading	7-Day Loading		
EASTERN HEMLOCK-TAMARACK						
Select Structural	2x4	2155	2480	2695	1,200,000	NELMA NSLB
No.1		1335	1535	1670	1,100,000	
No.2		990	1140	1240	1,100,000	
No.3		605	695	755	900,000	
Stud		570	655	710	900,000	
Construction		775	895	970	1,000,000	
Standard		430	495	540	900,000	
Utility		200	230	250	800,000	
Select Structural	2x6	1870	2150	2335	1,200,000	
No.1		1160	1330	1450	1,100,000	
No.2		860	990	1075	1,100,000	
No.3		525	600	655	900,000	
Stud	520	595	645	900,000		
Select Structural	2x8	1725	1985	2155	1,200,000	
No.1		1070	1230	1335	1,100,000	
No.2		795	915	990	1,100,000	
No.3		485	555	605	900,000	
Select Structural	2x10	1580	1820	1975	1,200,000	
No.1		980	1125	1225	1,100,000	
No.2		725	835	910	1,100,000	
No.3		445	510	555	900,000	
Select Structural	2x12	1440	1655	1795	1,200,000	
No.1		890	1025	1115	1,100,000	
No.2		660	760	825	1,100,000	
No.3		405	465	505	900,000	
EASTERN SOFTWOODS						
Select Structural	2x4	2155	2480	2695	1,200,000	NELMA NSLB
No.1		1335	1535	1670	1,100,000	
No.2		990	1140	1240	1,100,000	
No.3		605	695	755	900,000	
Stud		570	655	710	900,000	
Construction		775	895	970	1,000,000	
Standard		430	495	540	900,000	
Utility		200	230	250	800,000	
Select Structural	2x6	1870	2150	2335	1,200,000	
No.1		1160	1330	1450	1,100,000	
No.2		860	990	1075	1,100,000	
No.3		525	600	655	900,000	
Stud	520	595	645	900,000		
Select Structural	2x8	1725	1985	2155	1,200,000	
No.1		1070	1230	1335	1,100,000	
No.2		795	915	990	1,100,000	
No.3		485	555	605	900,000	
Select Structural	2x10	1580	1820	1975	1,200,000	
No.1		980	1125	1225	1,100,000	
No.2		725	835	910	1,100,000	
No.3		445	510	555	900,000	
Select Structural	2x12	1440	1655	1795	1,200,000	
No.1		890	1025	1115	1,100,000	
No.2		660	760	825	1,100,000	
No.3		405	465	505	900,000	

TABLE W-1 DESIGN VALUES FOR JOISTS AND RAFTERS - VISUALLY GRADED LUMBER

These "F_b" values are for use where repetitive members are spaced not more than 24 inches. For wider spacing, the "F_b" values shall be reduced 13%.
 Values for surfaced dry or surfaced green lumber apply at 19% maximum moisture content in use.

Species and Grade	Size	Design Value in Bending "F _b "			Modulus of Elasticity "E"	Grading Rules Agency
		Normal Duration	Snow Loading	7-Day Loading		
EASTERN WHITE PINE						
Select Structural	2x4	2155	2480	2695	1,200,000	NELMA NSLB
No.1		1335	1535	1670	1,100,000	
No.2		990	1140	1240	1,100,000	
No.3		605	695	755	900,000	
Stud		570	655	710	900,000	
Construction		775	895	970	1,000,000	
Standard		430	495	540	900,000	
Utility		200	230	250	800,000	
Select Structural	2x6	1870	2150	2335	1,200,000	
No.1		1160	1330	1450	1,100,000	
No.2		860	990	1075	1,100,000	
No.3		525	600	655	900,000	
Stud	520	595	645	900,000		
Select Structural	2x8	1725	1985	2155	1,200,000	
No.1		1070	1230	1335	1,100,000	
No.2		795	915	990	1,100,000	
No.3	485	555	605	900,000		
Select Structural	2x10	1580	1820	1975	1,200,000	
No.1		980	1125	1225	1,100,000	
No.2		725	835	910	1,100,000	
No.3	445	510	555	900,000		
Select Structural	2x12	1440	1655	1795	1,200,000	
No.1		890	1025	1115	1,100,000	
No.2		660	760	825	1,100,000	
No.3	405	465	505	900,000		
HEM-FIR						
Select Structural	2x4	2415	2775	3020	1,600,000	WCLIB WWPA
No.1 & Btr		1810	2085	2265	1,500,000	
No.1		1640	1885	2050	1,500,000	
No.2		1465	1685	1835	1,300,000	
No.3		865	990	1080	1,200,000	
Stud		855	980	1065	1,200,000	
Construction		1120	1290	1400	1,300,000	
Standard		635	725	790	1,200,000	
Utility	290	330	360	1,100,000		
Select Structural	2x6	2095	2405	2615	1,600,000	
No.1 & Btr		1570	1805	1960	1,500,000	
No.1		1420	1635	1775	1,500,000	
No.2		1270	1460	1590	1,300,000	
No.3		750	860	935	1,200,000	
Stud	775	895	970	1,200,000		
Select Structural	2x8	1930	2220	2415	1,600,000	
No.1 & Btr		1450	1665	1810	1,500,000	
No.1		1310	1510	1640	1,500,000	
No.2		1175	1350	1465	1,300,000	
No.3	690	795	865	1,200,000		
Select Structural	2x10	1770	2035	2215	1,600,000	
No.1 & Btr		1330	1525	1660	1,500,000	
No.1		1200	1380	1500	1,500,000	
No.2		1075	1235	1345	1,300,000	
No.3	635	725	790	1,200,000		
Select Structural	2x12	1610	1850	2015	1,600,000	
No.1 & Btr		1210	1390	1510	1,500,000	
No.1		1095	1255	1365	1,500,000	
No.2		980	1125	1220	1,300,000	
No.3	575	660	720	1,200,000		

TABLE W-1 DESIGN VALUES FOR JOISTS AND RAFTERS - VISUALLY GRADED LUMBER

These "F_b" values are for use where repetitive members are spaced not more than 24 inches. For wider spacing, the "F_b" values shall be reduced 13%.

Values for surfaced dry or surfaced green lumber apply at 19% maximum moisture content in use.

Species and Grade	Size	Design Value in Bending "F _b "			Modulus of Elasticity "E"	Grading Rules Agency
		Normal Duration	Snow Loading	7-Day Loading		
HEM-FIR (NORTH)						
Select Structural	2x4	2245	2580	2805	1,700,000	NLGA
No.1/No.2		1725	1985	2155	1,600,000	
No.3		990	1140	1240	1,400,000	
Stud		980	1125	1225	1,400,000	
Construction		1325	1520	1655	1,500,000	
Standard		720	825	900	1,400,000	
Utility		345	395	430	1,300,000	
Select Structural	2x6	1945	2235	2430	1,700,000	
No.1/No.2		1495	1720	1870	1,600,000	
No.3		860	990	1075	1,400,000	
Stud		890	1025	1115	1,400,000	
Select Structural	2x8	1795	2065	2245	1,700,000	
No.1/No.2		1380	1585	1725	1,600,000	
No.3		795	915	990	1,400,000	
Select Structural	2x10	1645	1890	2055	1,700,000	
No.1/No.2		1265	1455	1580	1,600,000	
No.3		725	835	910	1,400,000	
Select Structural	2x12	1495	1720	1870	1,700,000	
No.1/No.2		1150	1325	1440	1,600,000	
No.3		660	760	825	1,400,000	
MIXED MAPLE						
Select Structural	2x4	1725	1985	2155	1,300,000	NELMA
No.1		1250	1440	1565	1,200,000	
No.2		1210	1390	1510	1,100,000	
No.3		690	795	865	1,000,000	
Stud		695	800	870	1,000,000	
Construction		920	1060	1150	1,100,000	
Standard		520	595	645	1,000,000	
Utility	260	300	325	900,000		
Select Structural	2x6	1495	1720	1870	1,300,000	
No.1		1085	1245	1355	1,200,000	
No.2		1045	1205	1310	1,100,000	
No.3		600	690	750	1,000,000	
Stud	635	725	790	1,000,000		
Select Structural	2x8	1380	1585	1725	1,300,000	
No.1		1000	1150	1250	1,200,000	
No.2		965	1110	1210	1,100,000	
No.3		550	635	690	1,000,000	
Select Structural	2x10	1265	1455	1580	1,300,000	
No.1		915	1055	1145	1,200,000	
No.2		885	1020	1105	1,100,000	
No.3		505	580	635	1,000,000	
Select Structural	2x12	1150	1325	1440	1,300,000	
No.1		835	960	1040	1,200,000	
No.2		805	925	1005	1,100,000	
No.3		460	530	575	1,000,000	

TABLE W-1 DESIGN VALUES FOR JOISTS AND RAFTERS - VISUALLY GRADED LUMBER

These "F_b" values are for use where repetitive members are spaced not more than 24 inches. For wider spacing, the "F_b" values shall be reduced 13%.
 Values for surfaced dry or surfaced green lumber apply at 19% maximum moisture content in use.

Species and Grade	Size	Design Value in Bending "F _b "			Modulus of Elasticity "E"	Grading Rules Agency
		Normal Duration	Snow Loading	7-Day Loading		
MIXED OAK						
Select Structural	2x4	1985	2280	2480	1,100,000	NELMA
No.1		1425	1635	1780	1,000,000	
No.2		1380	1585	1725	900,000	
No.3		820	940	1025	800,000	
Stud		790	910	990	800,000	
Construction		1065	1225	1330	900,000	
Standard		605	695	755	800,000	
Utility		290	330	360	800,000	
Select Structural	2x6	1720	1975	2150	1,100,000	
No.1		1235	1420	1540	1,000,000	
No.2		1195	1375	1495	900,000	
No.3		710	815	890	800,000	
Stud	720	825	900	800,000		
Select Structural	2x8	1585	1825	1985	1,100,000	
No.1		1140	1310	1425	1,000,000	
No.2		1105	1270	1380	900,000	
No.3		655	755	820	800,000	
Select Structural	2x10	1455	1675	1820	1,100,000	
No.1		1045	1200	1305	1,000,000	
No.2		1010	1165	1265	900,000	
No.3		600	690	750	800,000	
Select Structural	2x12	1325	1520	1655	1,100,000	
No.1		950	1090	1185	1,000,000	
No.2		920	1060	1150	900,000	
No.3		545	630	685	800,000	
MIXED SOUTHERN PINE						
Select Structural	2x4	2360	2710	2950	1,600,000	SPIB
No.1		1670	1920	2080	1,500,000	
No.2		1500	1720	1870	1,400,000	
No.3		865	990	1080	1,200,000	
Stud		890	1020	1110	1,200,000	
Construction		1150	1320	1440	1,300,000	
Standard		635	725	790	1,200,000	
Utility		315	365	395	1,100,000	
Select Structural	2x6	2130	2450	2660	1,600,000	
No.1		1490	1720	1870	1,500,000	
No.2		1320	1520	1650	1,400,000	
No.3		775	895	970	1,200,000	
Stud		775	895	970	1,200,000	
Select Structural	2x8	2010	2310	2520	1,600,000	
No.1		1380	1590	1720	1,500,000	
No.2		1210	1390	1510	1,400,000	
No.3		720	825	900	1,200,000	
Select Structural	2x10	1730	1980	2160	1,600,000	
No.1		1210	1390	1510	1,500,000	
No.2		1060	1220	1330	1,400,000	
No.3		605	695	755	1,200,000	
Select Structural	2x12	1610	1850	2010	1,600,000	
No.1		1120	1290	1400	1,500,000	
No.2		1010	1160	1260	1,400,000	
No.3		575	660	720	1,200,000	

TABLE W-1 DESIGN VALUES FOR JOISTS AND RAFTERS - VISUALLY GRADED LUMBER

These "F_b" values are for use where repetitive members are spaced not more than 24 inches. For wider spacing, the "F_b" values shall be reduced 13%.

Values for surfaced dry or surfaced green lumber apply at 19% maximum moisture content in use.

Species and Grade	Size	Design Value in Bending "F _b "			Modulus of Elasticity "E"	Grading Rules Agency
		Normal Duration	Snow Loading	7-Day Loading		
NORTHERN RED OAK						
Select Structural	2x4	2415	2775	3020	1,400,000	NELMA
No.1		1725	1985	2155	1,400,000	
No.2		1680	1935	2100	1,300,000	
No.3		950	1090	1185	1,200,000	
Stud		950	1090	1185	1,200,000	
Construction		1265	1455	1580	1,200,000	
Standard		720	825	900	1,100,000	
Utility		345	395	430	1,000,000	
Select Structural	2x6	2095	2405	2615	1,400,000	
No.1		1495	1720	1870	1,400,000	
No.2		1460	1675	1820	1,300,000	
No.3		820	945	1030	1,200,000	
Stud		865	990	1080	1,200,000	
Select Structural	2x8	1930	2220	2415	1,400,000	
No.1		1380	1585	1725	1,400,000	
No.2		1345	1545	1680	1,300,000	
No.3		760	875	950	1,200,000	
Select Structural	2x10	1770	2035	2215	1,400,000	
No.1		1265	1455	1580	1,400,000	
No.2		1235	1420	1540	1,300,000	
No.3		695	800	870	1,200,000	
Select Structural	2x12	1610	1850	2015	1,400,000	
No.1		1150	1325	1440	1,400,000	
No.2		1120	1290	1400	1,300,000	
No.3		635	725	790	1,200,000	
NORTHERN SPECIES						
Select Structural	2x4	1640	1885	2050	1,100,000	NLGA
No.1/No.2		990	1140	1240	1,100,000	
No.3		605	695	755	1,000,000	
Stud		570	655	710	1,000,000	
Construction		775	895	970	1,000,000	
Standard		430	495	540	900,000	
Utility		200	230	250	900,000	
Select Structural		2x6	1420	1635	1775	
No.1/No.2	860		990	1075	1,100,000	
No.3	525		600	655	1,000,000	
Stud	520		595	645	1,000,000	
Select Structural	2x8	1310	1510	1640	1,100,000	
No.1/No.2		795	915	990	1,100,000	
No.3		485	555	605	1,000,000	
Select Structural	2x10	1200	1380	1500	1,100,000	
No.1/No.2		725	835	910	1,100,000	
No.3		445	510	555	1,000,000	
Select Structural	2x12	1095	1255	1365	1,100,000	
No.1/No.2		660	760	825	1,100,000	
No.3		405	465	505	1,000,000	

TABLE W-1 DESIGN VALUES FOR JOISTS AND RAFTERS - VISUALLY GRADED LUMBER

These "F_b" values are for use where repetitive members are spaced not more than 24 inches. For wider spacing, the "F_b" values shall be reduced 13%.

Values for surfaced dry or surfaced green lumber apply at 19% maximum moisture content in use.

Species and Grade	Size	Design Value in Bending "F _b "			Modulus of Elasticity "E"	Grading Rules Agency
		Normal Duration	Snow Loading	7-Day Loading		
NORTHERN WHITE CEDAR						
Select Structural		1335	1535	1670	800,000	NELMA
No.1		990	1140	1240	700,000	
No.2		950	1090	1185	700,000	
No.3	2x4	560	645	700	600,000	
Stud		540	620	670	600,000	
Construction Standard		720	825	900	700,000	
Utility		405	465	505	600,000	
		200	230	250	600,000	
Select Structural		1160	1330	1450	800,000	
No.1		860	990	1075	700,000	
No.2	2x6	820	945	1030	700,000	
No.3		485	560	605	600,000	
Stud		490	560	610	600,000	
Select Structural		1070	1230	1335	800,000	
No.1		795	915	990	700,000	
No.2	2x8	760	875	950	700,000	
No.3		450	515	560	600,000	
Select Structural		980	1125	1225	800,000	
No.1		725	835	910	700,000	
No.2	2x10	695	800	870	700,000	
No.3		410	475	515	600,000	
Select Structural		890	1025	1115	800,000	
No.1		660	760	825	700,000	
No.2	2x12	635	725	790	700,000	
No.3		375	430	465	600,000	
RED MAPLE						
Select Structural		2245	2580	2805	1,700,000	NELMA
No.1		1595	1835	1995	1,600,000	
No.2		1555	1785	1940	1,500,000	
No.3	2x4	905	1040	1130	1,300,000	
Stud		885	1020	1105	1,300,000	
Construction Standard		1210	1390	1510	1,400,000	
Utility		660	760	825	1,300,000	
		315	365	395	1,200,000	
Select Structural		1945	2235	2430	1,700,000	
No.1		1385	1590	1730	1,600,000	
No.2		1345	1545	1680	1,500,000	
No.3	2x6	785	905	980	1,300,000	
Stud		805	925	1005	1,300,000	
Select Structural		1795	2065	2245	1,700,000	
No.1		1275	1470	1595	1,600,000	
No.2	2x8	1240	1430	1555	1,500,000	
No.3		725	835	905	1,300,000	
Select Structural		1645	1890	2055	1,700,000	
No.1		1170	1345	1465	1,600,000	
No.2	2x10	1140	1310	1425	1,500,000	
No.3		665	765	830	1,300,000	
Select Structural		1495	1720	1870	1,700,000	
No.1		1065	1225	1330	1,600,000	
No.2	2x12	1035	1190	1295	1,500,000	
No.3		605	695	755	1,300,000	

TABLE W-1 DESIGN VALUES FOR JOISTS AND RAFTERS - VISUALLY GRADED LUMBER

These "F_b" values are for use where repetitive members are spaced not more than 24 inches. For wider spacing, the "F_b" values shall be reduced 13%.

Values for surfaced dry or surfaced green lumber apply at 19% maximum moisture content in use.

Species and Grade	Size	Design Value in Bending "F _b "			Modulus of Elasticity "E"	Grading Rules Agency
		Normal Duration	Snow Loading	7-Day Loading		
RED OAK						
Select Structural	2x4	1985	2280	2480	1,400,000	NELMA
No.1		1425	1635	1780	1,300,000	
No.2		1380	1585	1725	1,200,000	
No.3		820	940	1025	1,100,000	
Stud		790	910	990	1,100,000	
Construction		1065	1225	1330	1,200,000	
Standard		605	695	755	1,100,000	
Utility	290	330	360	1,000,000		
Select Structural	2x6	1720	1975	2150	1,400,000	
No.1		1235	1420	1540	1,300,000	
No.2		1195	1375	1495	1,200,000	
No.3		710	815	890	1,100,000	
Stud	720	825	900	1,100,000		
Select Structural	2x8	1585	1825	1985	1,400,000	
No.1		1140	1310	1425	1,300,000	
No.2		1105	1270	1380	1,200,000	
No.3	655	755	820	1,100,000		
Select Structural	2x10	1455	1675	1820	1,400,000	
No.1		1045	1200	1305	1,300,000	
No.2		1010	1165	1265	1,200,000	
No.3	600	690	750	1,100,000		
Select Structural	2x12	1325	1520	1655	1,400,000	
No.1		950	1090	1185	1,300,000	
No.2		920	1060	1150	1,200,000	
No.3	545	630	685	1,100,000		

TABLE W-1 DESIGN VALUES FOR JOISTS AND RAFTERS - VISUALLY GRADED LUMBER

These "F_b" values are for use where repetitive members are spaced not more than 24 inches. For wider spacing, the "F_b" values shall be reduced 13%.
 Values for surfaced dry or surfaced green lumber apply at 19% maximum moisture content in use.

Species and Grade	Size	Design Value in Bending "F _b "			Modulus of Elasticity "E"	Grading Rules Agency
		Normal Duration	Snow Loading	7-Day Loading		
REDWOOD						
Clear Structural	2x4	3020	3470	3775	1,400,000	RIS
Select Structural		2330	2680	2910	1,400,000	
Select Structural, open grain		1900	2180	2370	1,100,000	
No.1		1680	1935	2100	1,300,000	
No.1, open grain		1335	1535	1670	1,100,000	
No.2		1595	1835	1995	1,200,000	
No.2, open grain		1250	1440	1565	1,000,000	
No.3		905	1040	1130	1,100,000	
No.3, open grain		735	845	915	900,000	
Stud		725	835	910	900,000	
Construction Standard		950	1090	1185	900,000	
Utility		520	595	645	900,000	
			260	300	325	
Clear Structural	2x6	2615	3010	3270	1,400,000	
Select Structural		2020	2320	2525	1,400,000	
Select Structural, open grain		1645	1890	2055	1,100,000	
No.1		1460	1675	1820	1,300,000	
No.1, open grain		1160	1330	1450	1,100,000	
No.2		1385	1590	1730	1,200,000	
No.2, open grain		1085	1245	1355	1,000,000	
No.3		785	905	980	1,100,000	
No.3, open grain		635	730	795	900,000	
Stud	660	760	825	900,000		
Clear Structural	2x8	2415	2775	3020	1,400,000	
Select Structural		1865	2140	2330	1,400,000	
Select Structural, open grain		1520	1745	1900	1,100,000	
No.1		1345	1545	1680	1,300,000	
No.1, open grain		1070	1230	1335	1,100,000	
No.2		1275	1470	1595	1,200,000	
No.2, open grain		1000	1150	1250	1,000,000	
No.3		725	835	905	1,100,000	
No.3, open grain		585	675	735	900,000	
Clear Structural	2x10	2215	2545	2765	1,400,000	
Select Structural		1710	1965	2135	1,400,000	
Select Structural, open grain		1390	1600	1740	1,100,000	
No.1		1235	1420	1540	1,300,000	
No.1, open grain		980	1125	1225	1,100,000	
No.2		1170	1345	1465	1,200,000	
No.2, open grain		915	1055	1145	1,000,000	
No.3		665	765	830	1,100,000	
No.3, open grain		540	620	670	900,000	
Clear Structural	2x12	2015	2315	2515	1,400,000	
Select Structural		1555	1785	1940	1,400,000	
Select Structural, open grain		1265	1455	1580	1,100,000	
No.1		1120	1290	1400	1,300,000	
No.1, open grain		890	1025	1115	1,100,000	
No.2		1065	1225	1330	1,200,000	
No.2, open grain		835	960	1040	1,000,000	
No.3		605	695	755	1,100,000	
No.3, open grain		490	560	610	900,000	

TABLE W-1 DESIGN VALUES FOR JOISTS AND RAFTERS - VISUALLY GRADED LUMBER

These "F_b" values are for use where repetitive members are spaced not more than 24 inches. For wider spacing, the "F_b" values shall be reduced 13%.

Values for surfaced dry or surfaced green lumber apply at 19% maximum moisture content in use.

Species and Grade	Size	Design Value in Bending "F _b "			Modulus of Elasticity "E"	Grading Rules Agency
		Normal Duration	Snow Loading	7-Day Loading		
SOUTHERN PINE						
Dense Select Structural	2x4	3510	4030	4380	1,900,000	
Select Structural		3280	3770	4100	1,800,000	
Non-Dense Select Structural		3050	3500	3810	1,700,000	
No.1 Dense		2300	2650	2880	1,800,000	
No.1		2130	2450	2660	1,700,000	
No.1 Non-Dense		1950	2250	2440	1,600,000	
No.2 Dense		1960	2250	2440	1,700,000	
No.2		1720	1980	2160	1,600,000	
No.2 Non-Dense		1550	1790	1940	1,400,000	
No.3		980	1120	1220	1,400,000	
Stud		1010	1160	1260	1,400,000	
Construction		1270	1450	1580	1,500,000	
Standard		720	825	900	1,300,000	
Utility		345	395	430	1,300,000	
Dense Select Structural	2x6	3100	3570	3880	1,900,000	
Select Structural		2930	3370	3670	1,800,000	
Non-Dense Select Structural		2700	3110	3380	1,700,000	
No.1 Dense		2010	2310	2520	1,800,000	
No.1		1900	2180	2370	1,700,000	
No.1 Non-Dense		1720	1980	2160	1,600,000	
No.2 Dense		1670	1920	2080	1,700,000	
No.2		1440	1650	1800	1,600,000	
No.2 Non-Dense		1320	1520	1650	1,400,000	
No.3		865	990	1080	1,400,000	
Stud	890	1020	1110	1,400,000		
Dense Select Structural	2x8	2820	3240	3520	1,900,000	SPIB
Select Structural		2650	3040	3310	1,800,000	
Non-Dense Select Structural		2420	2780	3020	1,700,000	
No.1 Dense		1900	2180	2370	1,800,000	
No.1		1730	1980	2160	1,700,000	
No.1 Non-Dense		1550	1790	1940	1,600,000	
No.2 Dense		1610	1850	2010	1,700,000	
No.2		1380	1590	1720	1,600,000	
No.2 Non-Dense		1260	1450	1580	1,400,000	
No.3		805	925	1010	1,400,000	
Dense Select Structural	2x10	2470	2840	3090	1,900,000	
Select Structural		2360	2710	2950	1,800,000	
Non-Dense Select Structural		2130	2450	2660	1,700,000	
No.1 Dense		1670	1920	2080	1,800,000	
No.1		1500	1720	1870	1,700,000	
No.1 Non-Dense		1380	1590	1730	1,600,000	
No.2 Dense		1380	1590	1730	1,700,000	
No.2		1210	1390	1510	1,600,000	
No.2 Non-Dense		1090	1260	1370	1,400,000	
No.3		690	795	865	1,400,000	
Dense Select Structural	2x12	2360	2710	2950	1,900,000	
Select Structural		2190	2510	2730	1,800,000	
Non-Dense Select Structural		2010	2310	2520	1,700,000	
No.1 Dense		1550	1790	1940	1,800,000	
No.1		1440	1650	1800	1,700,000	
No.1 Non-Dense		1320	1520	1650	1,600,000	
No.2 Dense		1320	1520	1650	1,700,000	
No.2		1120	1290	1400	1,600,000	
No.2 Non-Dense		1040	1190	1290	1,400,000	
No.3		660	760	825	1,400,000	

TABLE W-1 DESIGN VALUES FOR JOISTS AND RAFTERS - VISUALLY GRADED LUMBER

These "F_b" values are for use where repetitive members are spaced not more than 24 inches. For wider spacing, the "F_b" values shall be reduced 13%.

Values for surfaced dry or surfaced green lumber apply at 19% maximum moisture content in use.

Species and Grade	Size	Design Value in Bending "F _b "			Modulus of Elasticity "E"	Grading Rules Agency
		Normal Duration	Snow Loading	7-Day Loading		
SPRUCE-PINE-FIR						
Select Structural	2x4	2155	2480	2695	1,500,000	NLGA
No.1/No.2		1510	1735	1885	1,400,000	
No.3		865	990	1080	1,200,000	
Stud		855	980	1065	1,200,000	
Construction		1120	1290	1400	1,300,000	
Standard		635	725	790	1,200,000	
Utility		290	330	360	1,100,000	
Select Structural	2x6	1870	2150	2335	1,500,000	
No.1/No.2		1310	1505	1635	1,400,000	
No.3		750	860	935	1,200,000	
Stud	775	895	970	1,200,000		
Select Structural	2x8	1725	1985	2155	1,500,000	
No.1/No.2		1210	1390	1510	1,400,000	
No.3		690	795	865	1,200,000	
Select Structural	2x10	1580	1820	1975	1,500,000	
No.1/No.2		1105	1275	1385	1,400,000	
No.3		635	725	790	1,200,000	
Select Structural	2x12	1440	1655	1795	1,500,000	
No.1/No.2		1005	1155	1260	1,400,000	
No.3		575	660	720	1,200,000	
SPRUCE-PINE-FIR (SOUTH)						
Select Structural	2x4	2245	2580	2805	1,300,000	NELMA NSLB WCLIB WWPA
No.1		1465	1685	1835	1,200,000	
No.2		1295	1490	1615	1,100,000	
No.3		735	845	915	1,000,000	
Stud		725	835	910	1,000,000	
Construction		980	1125	1220	1,000,000	
Standard		545	630	685	900,000	
Utility	260	300	325	900,000		
Select Structural	2x6	1945	2235	2430	1,300,000	
No.1		1270	1460	1590	1,200,000	
No.2		1120	1290	1400	1,100,000	
No.3		635	730	795	1,000,000	
Stud	660	760	825	1,000,000		
Select Structural	2x8	1795	2065	2245	1,300,000	
No.1		1175	1350	1465	1,200,000	
No.2		1035	1190	1295	1,100,000	
No.3	585	675	735	1,000,000		
Select Structural	2x10	1645	1890	2055	1,300,000	
No.1		1075	1235	1345	1,200,000	
No.2		950	1090	1185	1,100,000	
No.3	540	620	670	1,000,000		
Select Structural	2x12	1495	1720	1870	1,300,000	
No.1		980	1125	1220	1,200,000	
No.2		865	990	1080	1,100,000	
No.3	490	560	610	1,000,000		

TABLE W-1 DESIGN VALUES FOR JOISTS AND RAFTERS - VISUALLY GRADED LUMBER

These "F_b" values are for use where repetitive members are spaced not more than 24 inches. For wider spacing, the "F_b" values shall be reduced 13%.

Values for surfaced dry or surfaced green lumber apply at 19% maximum moisture content in use.

Species and Grade	Size	Design Value in Bending "F _b "			Modulus of Elasticity "E"	Grading Rules Agency
		Normal Duration	Snow Loading	7-Day Loading		
WESTERN CEDARS						
Select Structural	2x4	1725	1985	2155	1,100,000	WCLIB WWPA
No.1		1250	1440	1565	1,000,000	
No.2		1210	1390	1510	1,000,000	
No.3		690	795	865	900,000	
Stud		695	800	870	900,000	
Construction		920	1060	1150	900,000	
Standard		520	595	645	800,000	
Utility		260	300	325	800,000	
Select Structural	2x6	1495	1720	1870	1,100,000	
No.1		1085	1245	1355	1,000,000	
No.2		1045	1205	1310	1,000,000	
No.3		600	690	750	900,000	
Stud	635	725	790	900,000		
Select Structural	2x8	1380	1585	1725	1,100,000	
No.1		1000	1150	1250	1,000,000	
No.2		965	1110	1210	1,000,000	
No.3		550	635	690	900,000	
Select Structural	2x10	1265	1455	1580	1,100,000	
No.1		915	1055	1145	1,000,000	
No.2		885	1020	1105	1,000,000	
No.3		505	580	635	900,000	
Select Structural	2x12	1150	1325	1440	1,100,000	
No.1		835	960	1040	1,000,000	
No.2		805	925	1005	1,000,000	
No.3		460	530	575	900,000	
WESTERN WOODS						
Select Structural	2x4	1510	1735	1885	1,200,000	WCLIB WWPA
No.1		1120	1290	1400	1,100,000	
No.2		1120	1290	1400	1,000,000	
No.3		645	745	810	900,000	
Stud		635	725	790	900,000	
Construction		835	960	1040	1,000,000	
Standard		460	530	575	900,000	
Utility		230	265	290	800,000	
Select Structural	2x6	1310	1505	1635	1,200,000	
No.1		970	1120	1215	1,100,000	
No.2		970	1120	1215	1,000,000	
No.3		560	645	700	900,000	
Stud		575	660	720	900,000	
Select Structural	2x8	1210	1390	1510	1,200,000	
No.1		895	1030	1120	1,100,000	
No.2		895	1030	1120	1,000,000	
No.3		520	595	645	900,000	
Select Structural	2x10	1105	1275	1385	1,200,000	
No.1		820	945	1030	1,100,000	
No.2		820	945	1030	1,000,000	
No.3		475	545	595	900,000	
Select Structural	2x12	1005	1155	1260	1,200,000	
No.1		750	860	935	1,100,000	
No.2		750	860	935	1,000,000	
No.3		430	495	540	900,000	

TABLE W-1 DESIGN VALUES FOR JOISTS AND RAFTERS - VISUALLY GRADED LUMBER

These "F_b" values are for use where repetitive members are spaced not more than 24 inches. For wider spacing, the "F_b" values shall be reduced 13%.

Values for surfaced dry or surfaced green lumber apply at 19% maximum moisture content in use.

Species and Grade	Size	Design Value in Bending "F _b "			Modulus of Elasticity "E"	Grading Rules Agency
		Normal Duration	Snow Loading	7-Day Loading		
WHITE OAK						
Select Structural	2x4	2070	2380	2590	1,100,000	NELMA
No.1		1510	1735	1885	1,000,000	
No.2		1465	1685	1835	900,000	
No.3		820	940	1025	800,000	
Stud		820	945	1030	800,000	
Construction		1095	1255	1365	900,000	
Standard		605	695	755	800,000	
Utility	290	330	360	800,000		
Select Structural	2x6	1795	2065	2245	1,100,000	
No.1		1310	1505	1635	1,000,000	
No.2		1270	1460	1590	900,000	
No.3		710	815	890	800,000	
Stud	750	860	935	800,000		
Select Structural	2x8	1655	1905	2070	1,100,000	
No.1		1210	1390	1510	1,000,000	
No.2		1175	1350	1465	900,000	
No.3		655	755	820	800,000	
Select Structural	2x10	1520	1745	1900	1,100,000	
No.1		1105	1275	1385	1,000,000	
No.2		1075	1235	1345	900,000	
No.3		600	690	750	800,000	
Select Structural	2x12	1380	1585	1725	1,100,000	
No.1		1005	1155	1260	1,000,000	
No.2		980	1125	1220	900,000	
No.3		545	630	685	800,000	
YELLOW POPLAR						
Select Structural	2x4	1725	1985	2155	1,500,000	NSLB
No.1		1250	1440	1565	1,400,000	
No.2		1210	1390	1510	1,300,000	
No.3		690	795	865	1,200,000	
Stud		695	800	870	1,200,000	
Construction		920	1060	1150	1,300,000	
Standard		520	595	645	1,100,000	
Utility	230	265	290	1,100,000		
Select Structural	2x6	1495	1720	1870	1,500,000	
No.1		1085	1245	1355	1,400,000	
No.2		1045	1205	1310	1,300,000	
No.3		600	690	750	1,200,000	
Stud		635	725	790	1,200,000	
Select Structural	2x8	1380	1585	1725	1,500,000	
No.1		1000	1150	1250	1,400,000	
No.2		965	1110	1210	1,300,000	
No.3		550	635	690	1,200,000	
Select Structural	2x10	1265	1455	1580	1,500,000	
No.1		915	1055	1145	1,400,000	
No.2		885	1020	1105	1,300,000	
No.3		505	580	635	1,200,000	
Select Structural	2x12	1150	1325	1440	1,500,000	
No.1		835	960	1040	1,400,000	
No.2		805	925	1005	1,300,000	
No.3		460	530	575	1,200,000	

TABLE FOOTNOTES

1. When dimension lumber is used where moisture content will exceed 19% for an extended time period, F_b shall be multiplied by 0.85 if F_b exceeds 1150 psi, and E shall be multiplied by 0.9.

2. Following is a list of agencies certified by the American Lumber Standards Committee Board of Review (as of 1991) for inspection and grading of untreated lumber under the rules indicated. For the most up-to-date list of certified agencies write to:

American Lumber Standards Committee
P.O. Box 210
Germantown, Maryland 20874

Rules Writing Agencies	Rules for which grading is authorized
Northeastern Lumber Manufacturers Association (NELMA)..... 272 Tuttle Road, P.O. Box 87A, Cumberland Center, Maine 04021	NELMA,NLGA
Northern Softwood Lumber Bureau (NSLB) 272 Tuttle Road, P.O. Box 87A, Cumberland Center, Maine 04021	NSLB,WCLIB,WWPA,NLGA
Redwood Inspection Service (RIS) 405 Enfrente Drive, Suite 200, Novato, California 94949	RIS,WCLIB,WWPA
Southern Pine Inspection Bureau (SPIB) 4709 Scenic Highway, Pensacola, Florida 32504	SPIB,NELMA
West Coast Lumber Inspection Bureau (WCLIB) 6980 SW Varnes Road, PO Box 23145, Portland, Oregon 97223	WCLIB,RIS,WWPA,NLGA
Western Wood Products Association (WWPA)..... 522 S.W. 5th Avenue, Yeon Building, Portland, OR 97204	WWPA,WCLIB,NLGA,RIS
National Lumber Grades Authority (NLGA) 260-1055 W. Hastings Street, Vancouver, B.C., Canada V6E 2E9	
Non-Rules Writing Agencies	
California Lumber Inspection Service	RIS,WCLIB,WWPA,NLGA
Pacific Lumber Inspection Bureau, Inc	RIS,WCLIB,WWPA,NLGA
Timber Products Inspection.....	RIS,SPIB,WCLIB,WWPA NELMA,NSLB,NLGA
Alberta Forest Products Association	NLGA
Canadian Lumbermen's Association.....	NLGA
Cariboo Lumber Manufacturers Association	NLGA
Central Forest Products Association.....	NLGA
Council of Forest Industries of British Columbia	NLGA
Interior Lumber Manufacturers Association	NLGA
Macdonald Inspection.....	NLGA
Maritime Lumber Bureau	NLGA
Ontario Lumber Manufacturers Association.....	NLGA
Pacific Lumber Inspection Bureau	NLGA
Quebec Lumber Manufacturers Association.....	NLGA

21.03(1), 21.03(5)(b), 21.03(6)(b) Separation of Exits

Note that these sections require the two required exits to be separated as far apart as practical. Any separation distance of less than one-half the longest diagonal measurement of that floor (see diagrams) should be closely scrutinized to see if better separation is feasible.

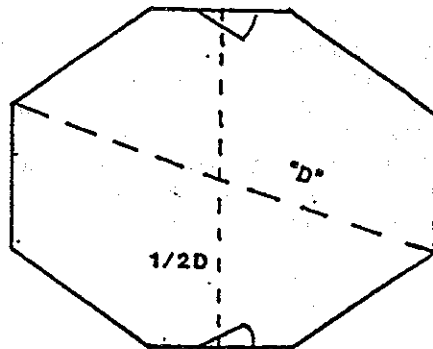
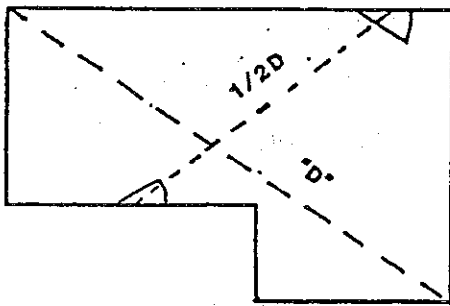
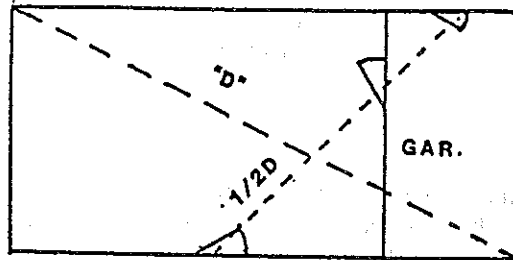
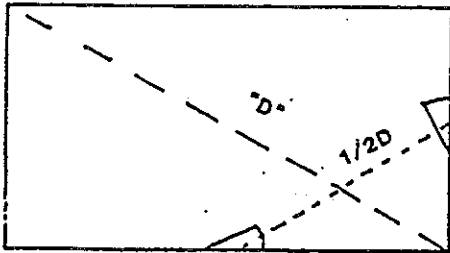

ss. ILHR 21.03(1), (5)(b), & (6)(b)
SEPARATION OF EXITS

HANDRAILS

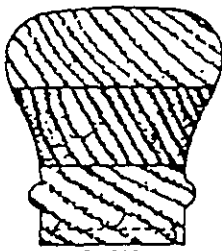

2-1/4 x 2-3/8"

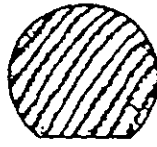

1-3/8 x 1-1/2



2-7/16 x 2-5/16"

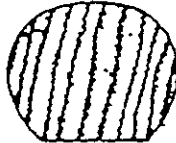

1-3/8 x 1-3/4

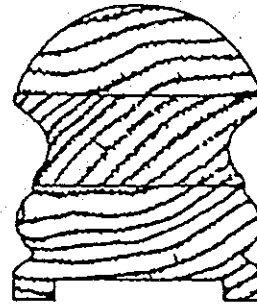

2-5/8 x 2-27/32"

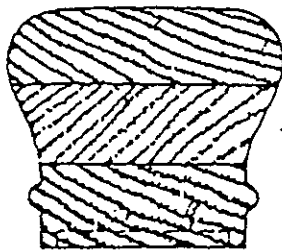

2-27/32 x 2-3/8"

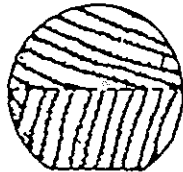

1-5/8 x 1-3/4

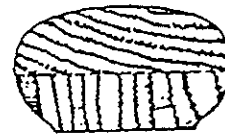

1-1/4 x 2-1/4

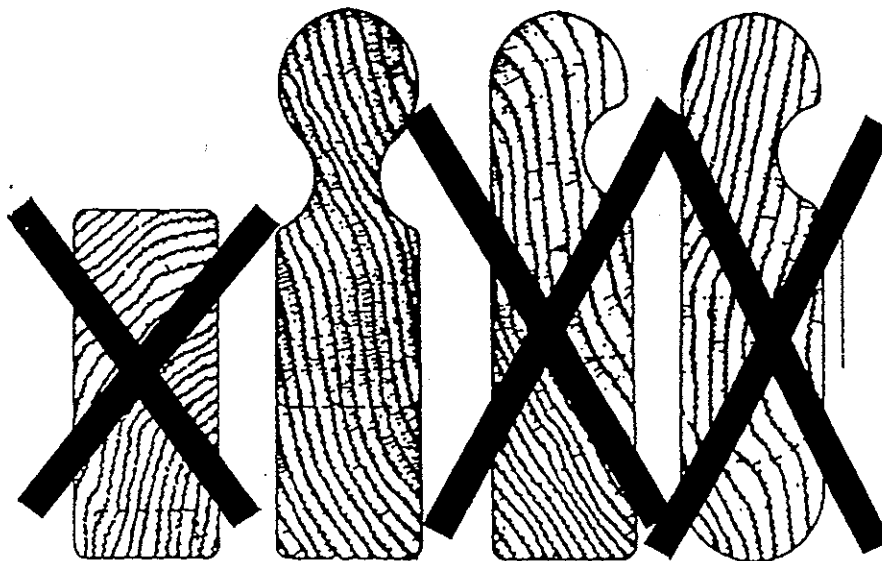

1-1/2 x 3-1/2

1-1/2 x 4

1-1/2 x 3-1/2

1-1/2 x 4-1/2

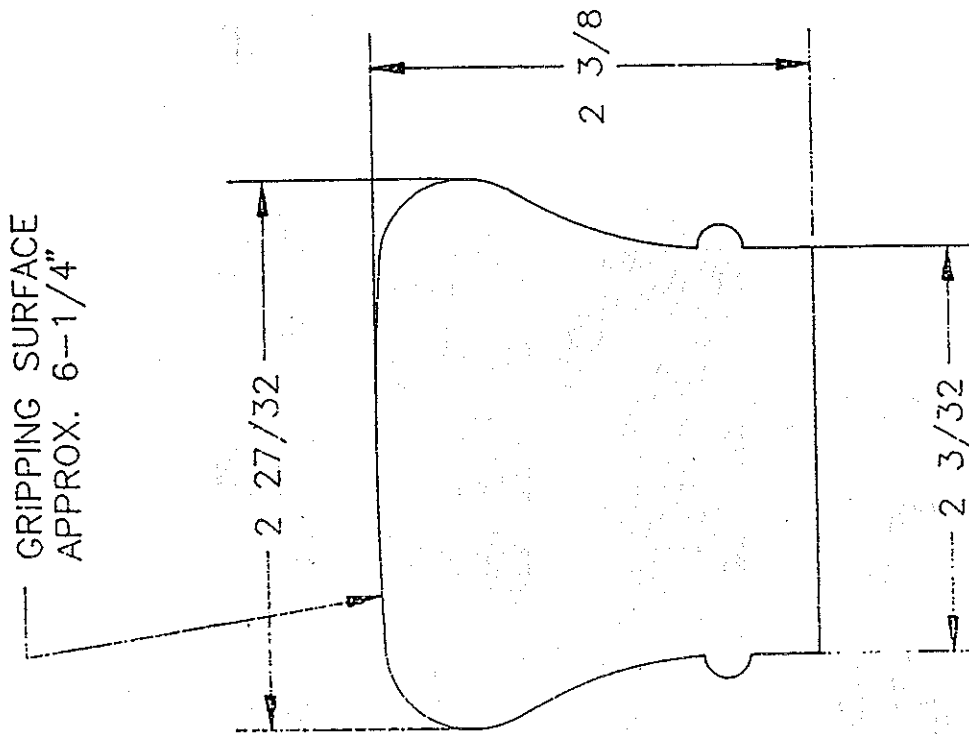
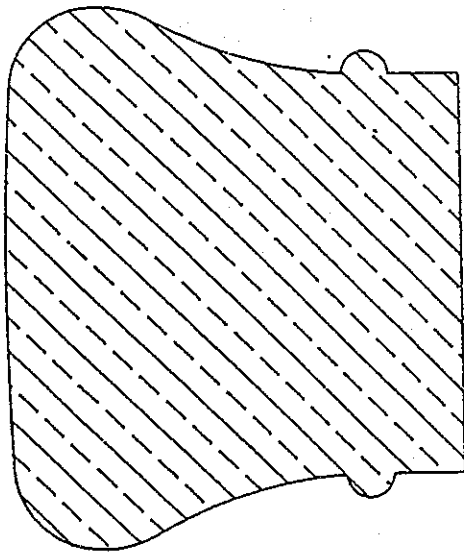

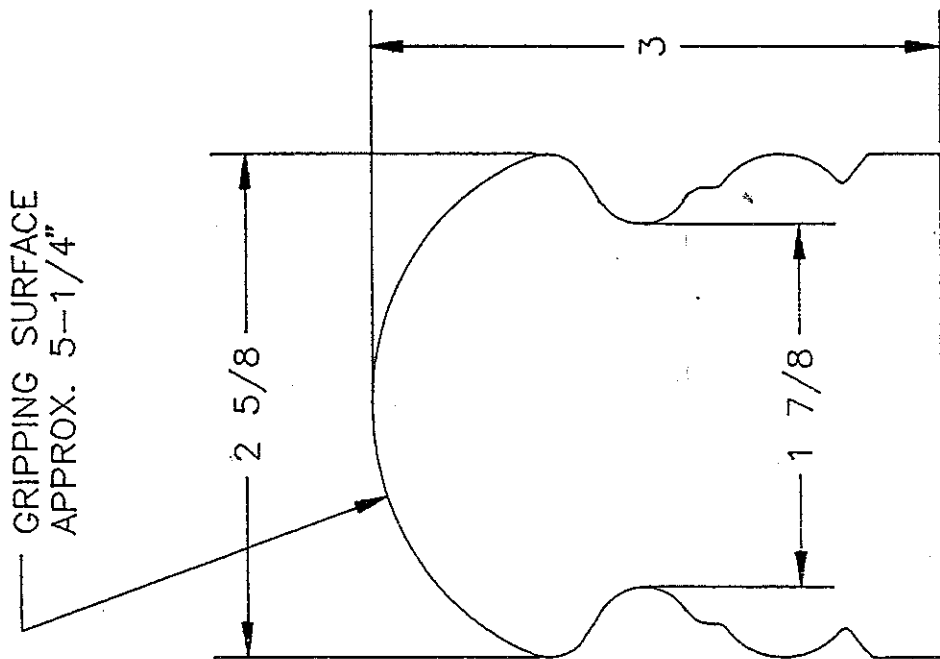
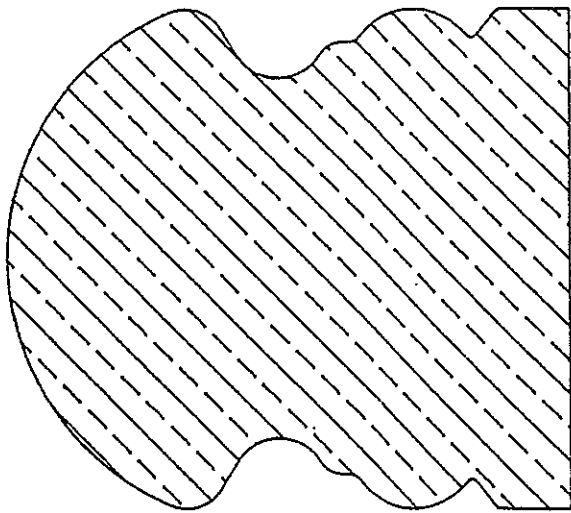

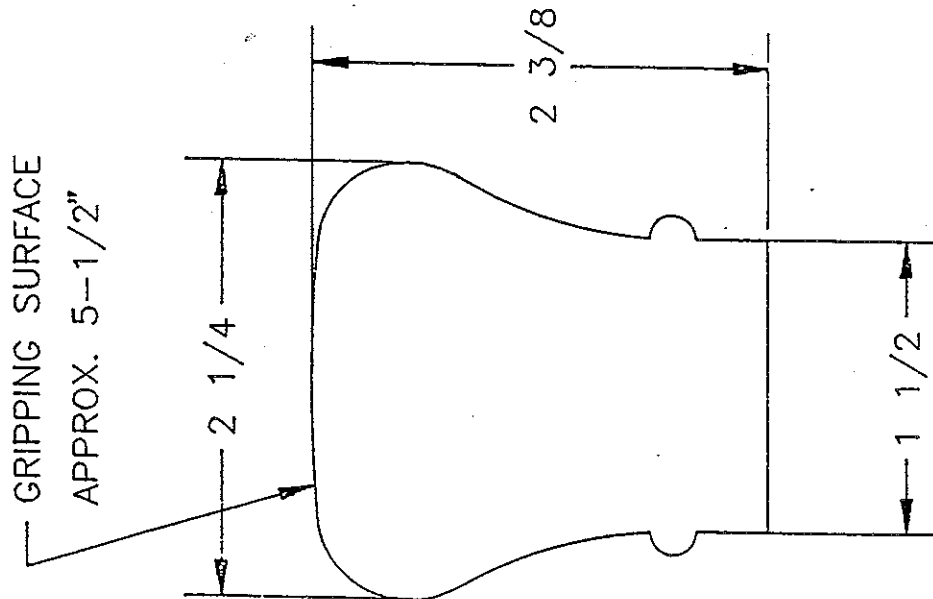
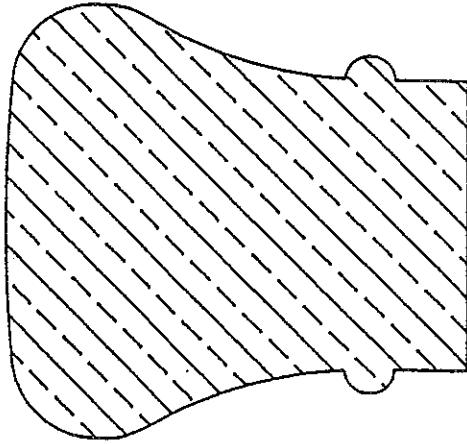

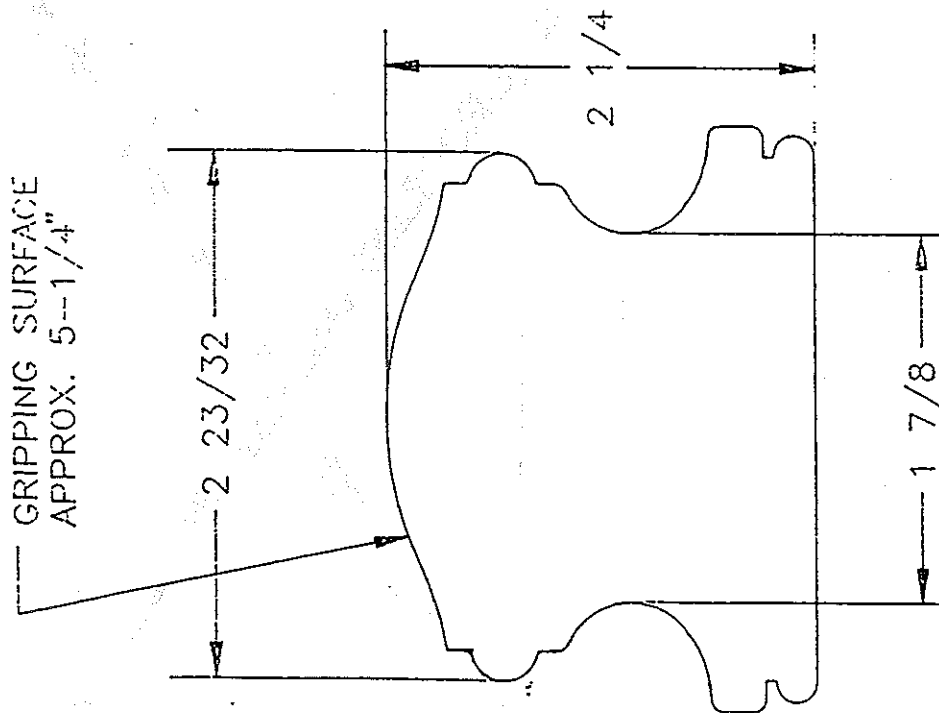
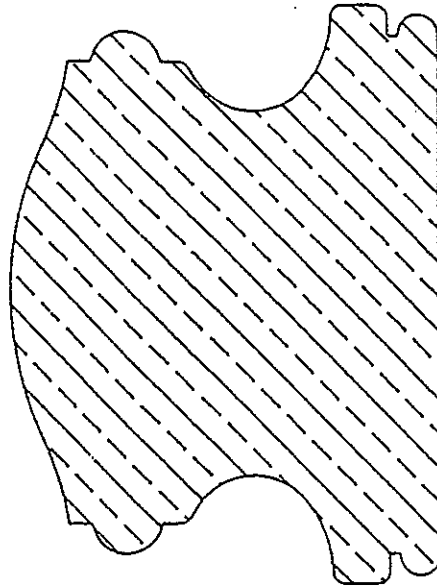

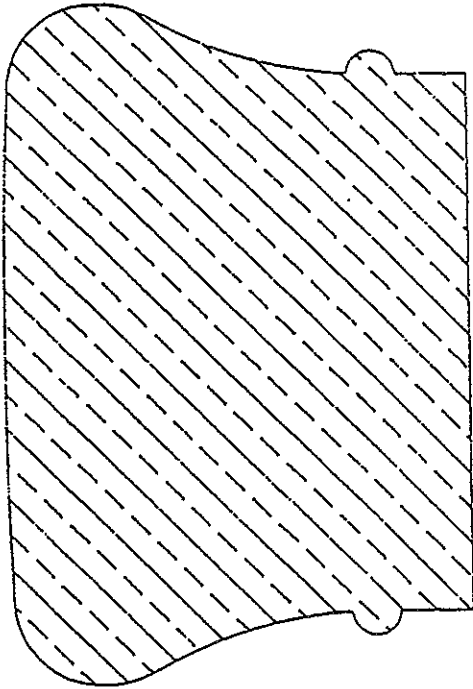

GRIPPING SURFACE
APPROX. 6-3/4"

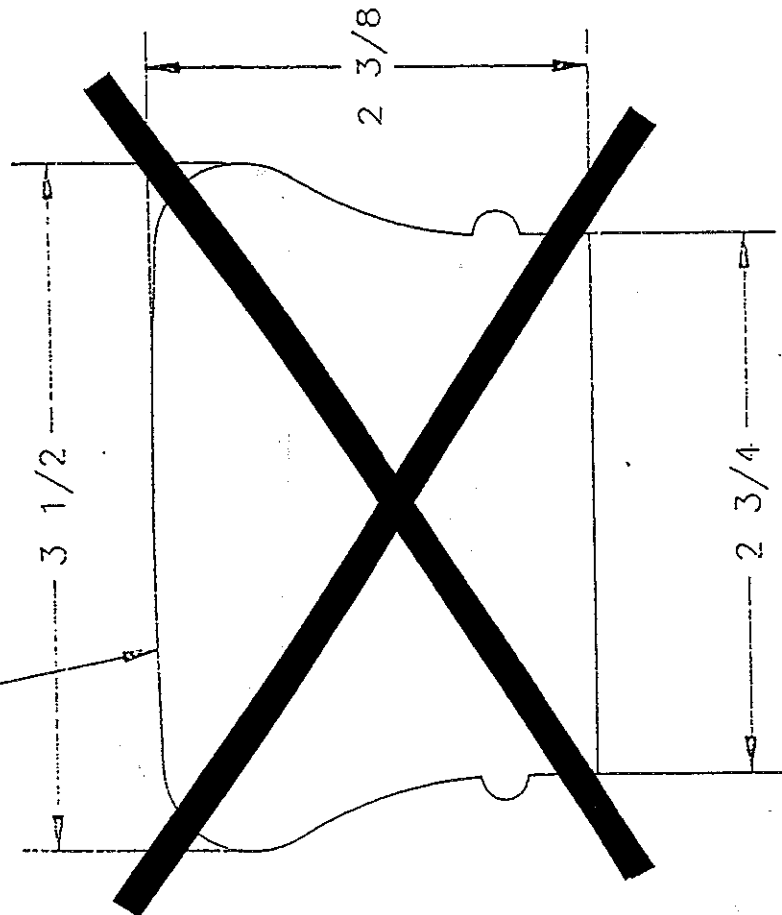

**APPENDIX
EROSION CONTROL PROCEDURES
EXAMPLES, ILLUSTRATIONS AND GUIDELINES**

The following examples and illustrations of some erosion control procedures are provided for your information. Many of these examples and accompanying illustrations are excerpted from the "Wisconsin Construction Site Best Management Practices Handbook", developed by the Wisconsin department of natural resources. The illustrations, Figures E-1 to E-10, depict the materials and installation of some erosion control procedures.

Note: The Handbook is available from Document sales, 202 South Thornton Avenue, P.O. Box 7840, Madison, WI 53707-8480; phone (608) 266-3358.

Also included in appendix are examples of plot plans depicting the best management practices that will help meet the requirements of the performance standards in this code. Figure E-11 is an example of a site with a simple slope (all slopes occurring in one general direction). Downslope measures are required, to reduce maintenance of these measures, the upslope diversion is recommended. Figure E-12 is an example of a site with complex slopes (slopes occurring in more than one direction). The location of the erosion control procedures are clearly indicated on the plot plan. Figure E-13 is an example of a large lot, greater than 5 acres, with slopes greater than 12% and where the area of land disturbing activity is indicated. This plan indicates the use of vegetative barriers.

Guidelines for timing the implementation of the erosion control practices and procedures in order to stabilize areas disturbed during construction of one and 2-family dwellings are included in this appendix. Dormant seeding, the guidelines for the use of vegetative buffers and the recommended maintenance for erosion control practices are also included.

For sites using either straw bales or silt fences as a perimeter control, Table E-1 is included as a guide for determining the distance between parallel fences constructed on various slopes. Perimeter measures should be installed at right angles to the direction of flow. Drainage area is to be no more than .25 acres (approx. 10,000 square feet) per 100 feet of perimeter control.

**TABLE E-1
DISTANCE BETWEEN PARALLEL
STRAW BALES OR SILT FENCES**

Slope Percent	Slope Distance (feet)
< 2%	100 feet
2 to 5%	75 feet
5 to 10%	50 feet
10 to 20%	25 feet
> 20%	15 feet

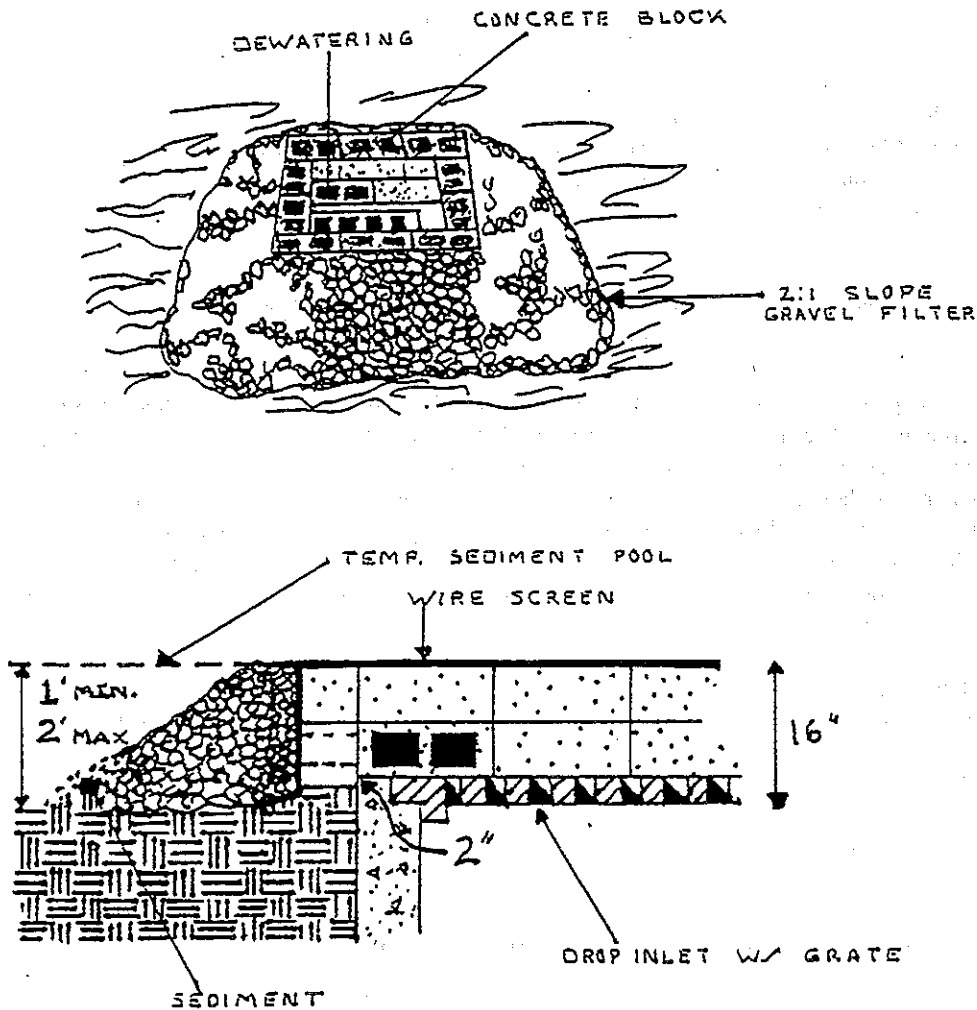
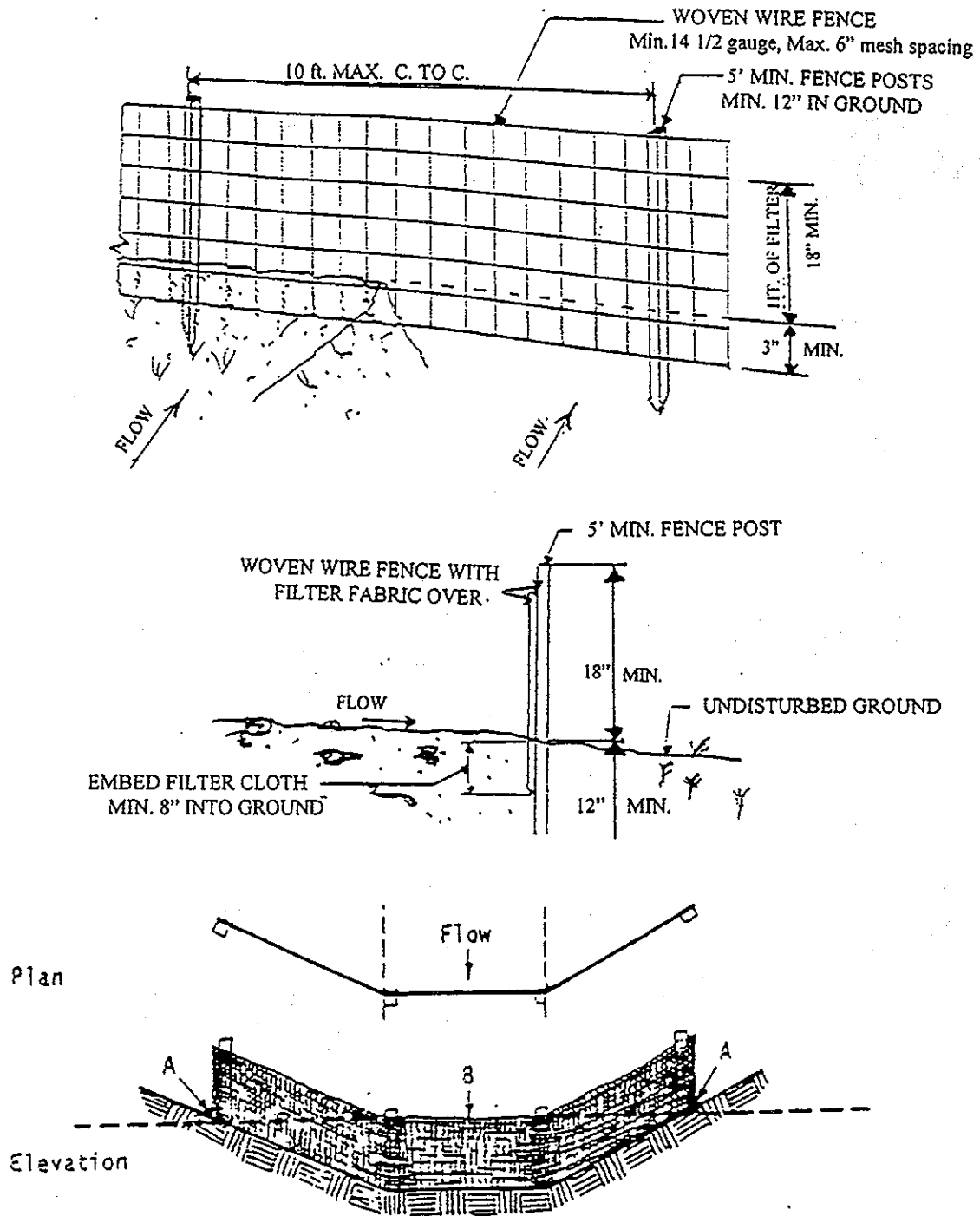

FIG. E-3. STONE & BLOCK DROP INLET PROTECTION

Source: New York Guidelines for Urban Erosion and Sediment Control, Oct. 1991

CONSTRUCTION SPECIFICATIONS

1. Lay one block on each side of the structure on its side for dewatering. Foundation shall be 2 inches minimum below rest of inlet and blocks shall be placed against inlet for support.
2. Hardware cloth or 1/2" wire mesh shall be placed over block openings to support stone.
3. Use clean stone or gravel 1/2-3/4 inch in diameter placed 2 inches below the top of the block on a 2:1 slope or flatter.



Points A should be higher than point B

PROPER PLACEMENT OF A FILTER BARRIER IN A DRAINAGE WAY

Source: Adapted from Installation of Straw and Fabric Filter Barriers for Sediment Control, Sherwood and Wyant

FIG. E-6
SUPPORTED FILTER BARRIER FOR USE IN A DRAINAGE WAY

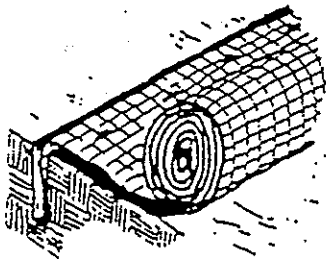

Anchor Slot: Bury the up-channel end of the net in a 6" deep trench. Tamp the soil firmly. Staple at 12" intervals across the net.

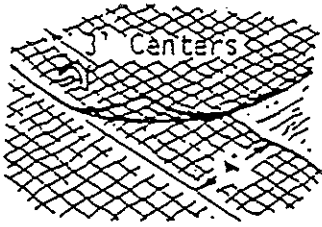

Overlap: Overlap edges of the strips at least 4". Staple every 3 feet down the center of the strip.

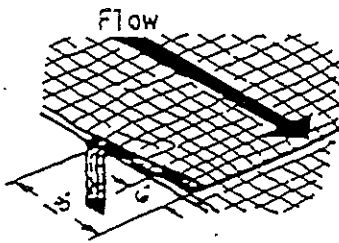
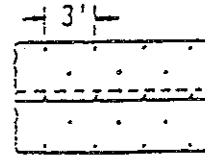

Joining Strips: Insert the new roll of net in a trench, as with the Anchor Slot. Overlap the up-channel end of the previous roll 18" and turn the end under 6". Staple the end of the previous roll just below the anchor slot and at the end at 12" intervals.

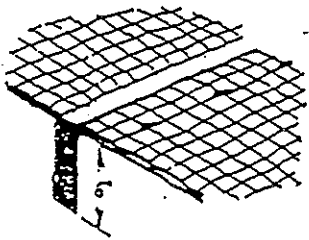

Check Slots: On erodible soils or steep slopes, check slots should be made every 15 feet. Insert a fold of the net into a 6" trench and tamp firmly. Staple at 12" intervals across the net. Lay the net smoothly on the surface of the soil - do not stretch the net, and do not allow wrinkles.

Anchoring Ends At Structures:

Place the end of the net in a 6" slot on the up-channel side of the structure. Fill the trench and tamp firmly. Roll the net up the channel. Place staples at 12" intervals along the anchor end of the net.

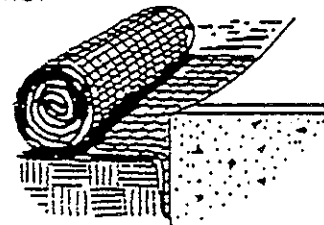
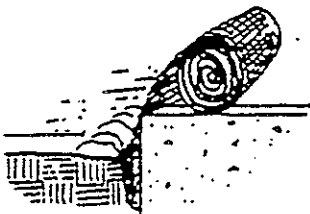
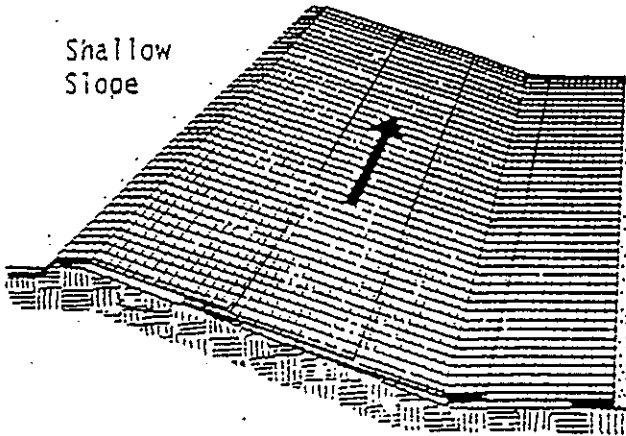

FIG. E-8(a) INSTALLATION OF NETTING OR MATTING
Note: If provided, follow manufacturer's installation specifications

Shallow
Slope



On shallow slopes, strips of netting may be applied across the slope.

Where there is a berm at the top of the slope, bring the netting over the berm and anchor it behind the berm.



Steep
Slope

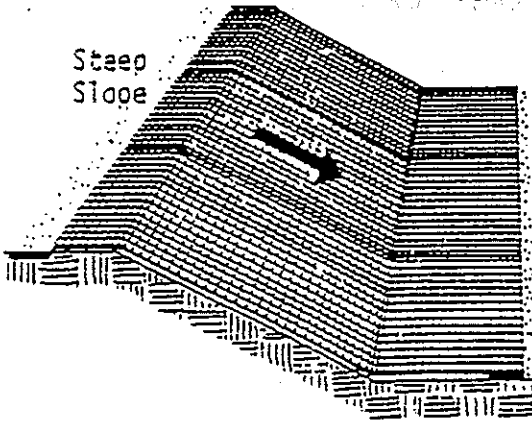

On steep slopes, apply strips of netting parallel to the direction of flow and anchor securely.

Bring netting down to a level area before terminating the installation. Turn the end under 6" and staple at 12" intervals.

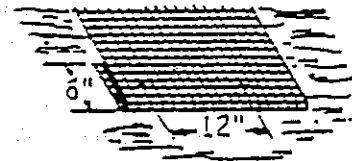

Ditch

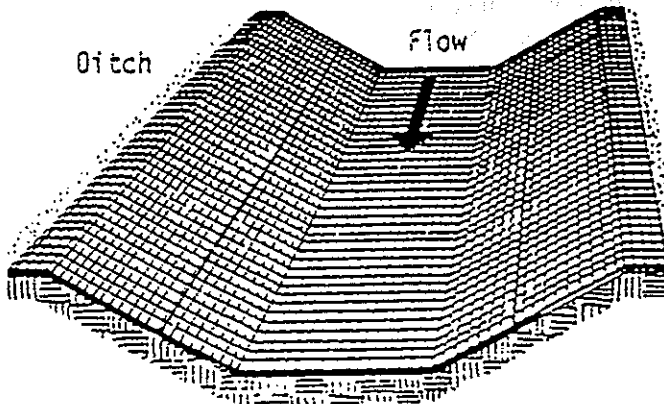

In ditches, apply netting parallel to the direction of flow. Use check slots every 15 feet. Do not join strips in the center of the ditch.

FIG. E-8(b) ORIENTATION OF NETTING OR MATTING
Note: If provided, follow manufacturer's installation specifications

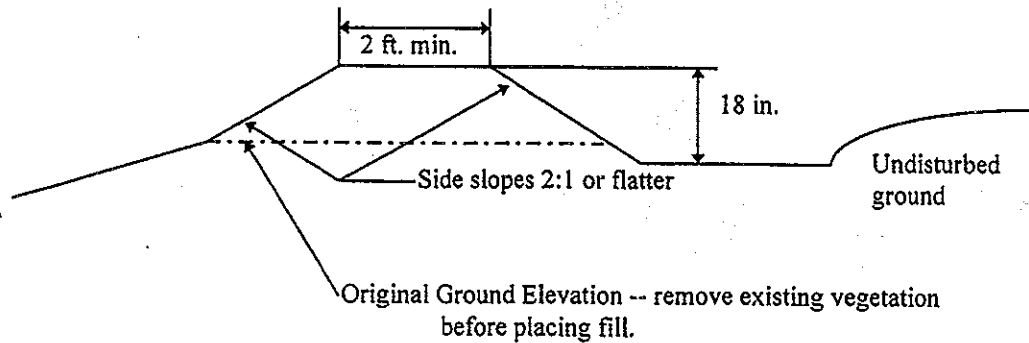

FIG. E-10. TEMPORARY DIVERSION

PURPOSE

To divert runoff around disturbed areas to a location where the clean water can be discharged to existing vegetation in such a way as to prevent any negative offsite impacts.

CONDITIONS WHERE PRACTICE APPLIES

1. Where drainage areas do not exceed 3 acres.
2. Upslope of disturbed areas where erosion is likely to occur.
3. Upslope of soil piles.
4. Above steep cut or fill slopes.

STABILIZATION

Diversions side slopes, ridge, downslope side of the berm and channel should be stabilized within 7 days of final grading by:

1. Sodding;
2. seeding and mulching in combination with filter fabric barriers or straw bale barriers;
3. covering with suitable geotextile;
4. covering with 6 mil polyethylene sheeting.

(vegetation should be used as the stabilization method if diversion is to be in place 30 days or longer)

NOTE: Diversions are to be constructed so the channel area is flat enough that an erosion problem is not created.

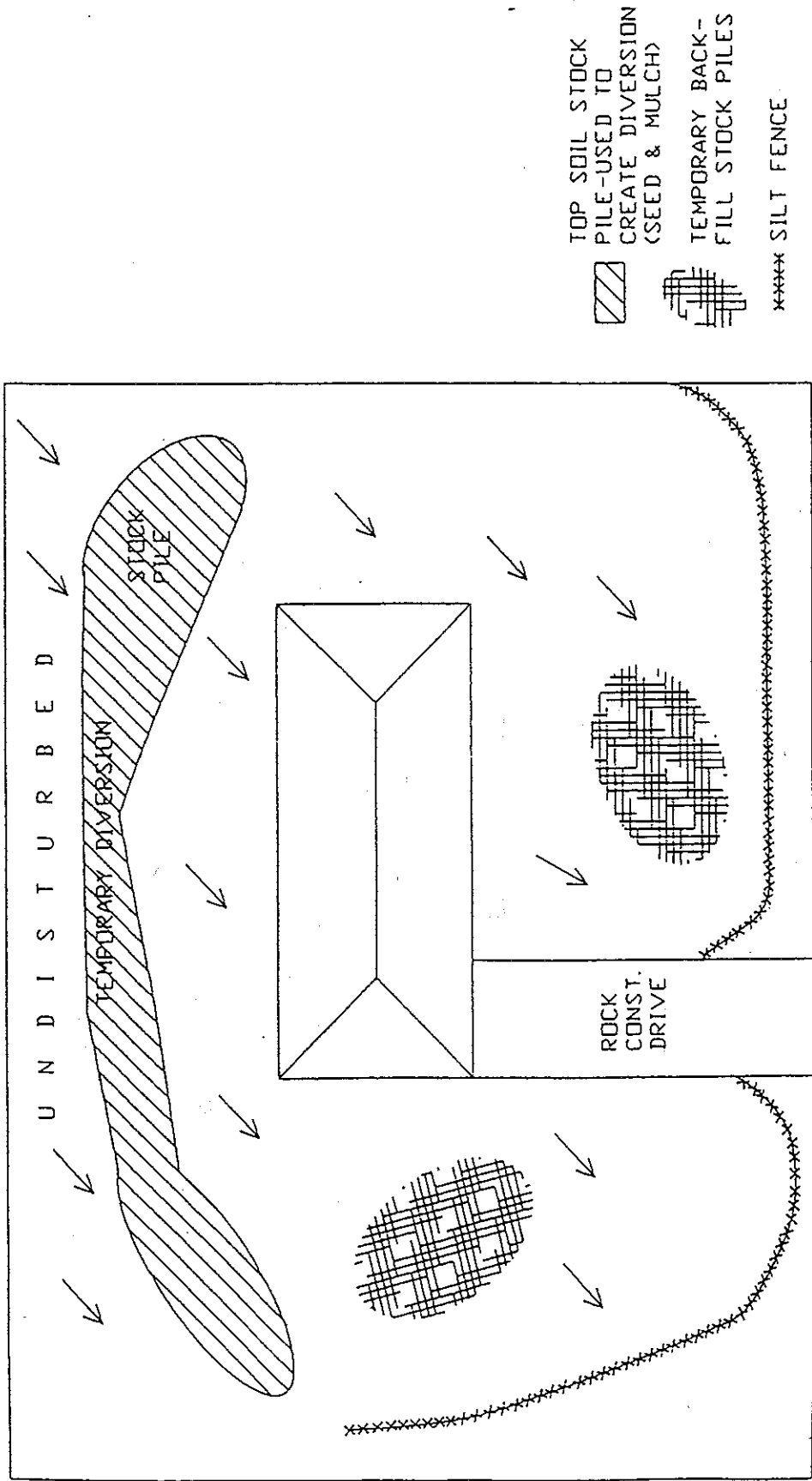

TOP SOIL STOCK PILE-USED TO CREATE DIVERSION (SEED & MULCH)

TEMPORARY BACK-FILL STOCK PILES

***** SILT FENCE

FIG. E 11. PLOT PLAN FOR SIMPLE SLOPES

VEGETATIVE BARRIERS

Vegetative barriers may be used as a perimeter measure if disturbed areas above consist of slopes no greater than 6% and barriers are on a grade no steeper than 2%. Vegetative barriers are to be a minimum of 10' wide for every 50 feet of open ground draining to them. These barriers must be maintained, i.e. not driven on or destroyed. If the barriers become covered with silt or otherwise destroyed, additional perimeter measures may be required.

TEMPORARY STABILIZATION OR MULCH CROP

It is much easier to control erosion than to control sediment. Temporary stabilization helps to minimize erosion and therefore the need for long term maintenance of silt fences and straw bales. Annual rye grass may be planted as a temporary cover between April 1 and September 15. If seeding is done in the spring or summer seeding dates and slopes are 6% or less, mulch may not be necessary.

Winter rye may be planted between July 15 and October 15. These seedings should be mulched.

LATE SEASON CONSTRUCTION MULCHING/DORMANT SEEDING

If ground is broken after September 15, mulch should be applied as soon as a rough grade is established, unless final grade and landscaping is to be completed before the next growing season. Mulch will help to reduce the raindrop impact. Seeding should not be done between September 15 and November 1 as the weather is warm enough for the seed to germinate but it will not have an opportunity to establish a root system strong enough to survive the winter. A dormant seeding may be done OVER the mulch after November 1. These seedings are risky. A split application of seed may also be made, using half in November and balance early in spring.

WINTER CONSTRUCTION

In areas with coarse soils, (sands) if excavation is possible most likely a trencher can be used to install the necessary silt fence. If at all possible leave the perimeter of the site undisturbed (this is assuming the site had vegetation present prior to frost); this may be the easiest erosion control for flat sites (6% or less). In areas that have heavy soils, (clays) close attention should be paid to the try to get perimeter measures installed prior to frost penetrating greater than 6". If ground is solidly frozen, perimeter measures may have to wait to be installed when the frost first starts to come out in the spring.

Maintenance of the most commonly used erosion control procedures in the construction of one and two family dwellings.

SILT FENCES

Repair or replacement should be done within 24 hours if fencing is torn, sagging, overtopped, blown over (laying down), shows a lack of integrity, or in any way is not functioning as designed. Sediment deposits should be removed after each storm event. Sediment deposits shall be removed when deposits reach 0.5 the above ground height of the fence. Silt fence should be removed after upland areas have been stabilized. Any sediment deposits remaining in place after the silt fence is no longer required should be dressed to conform to the existing grade, prepared and seeded.

STRAWBALES

Replacement of broken or torn bales should be done within 24 hours. Sediment deposits should be removed when deposits reach 0.5 the height of the fence. Strawbales should be removed after upland areas have been stabilized. Any sediment deposits remaining in place after the straw bale barrier is no longer required should be dressed to conform to the existing grade, prepared and seeded.

MULCHING

Additional mulch, netting or matting should be applied when rills develop. (rill - small eroded ditch measuring 1" wide).

TEMPORARY DIVERSIONS

Any breaks or eroded areas of a diversion should be repaired within 24 hours.

SEDIMENT TRAP

Any structural deficiencies should be repaired within 24 hours. Sediment should be removed when it reaches half of the outlet height of the trap.

SODDING

Repair or replacement of sod that has been destroyed in an area of channelized flow should be done within 24 hours after the rain event.

INLET PROTECTION BARRIERS

Sediment deposits should be removed when deposits reach 0.5 the height of the fence. Repair or replacement should be made to damaged barriers within 24 hours.

TEMPORARY GRAVELED ACCESS ROADS

Rock should be maintained to meet the design criteria of 2-3" aggregate stone; 7 feet wide and 50 feet long or the distance to the foundation, whichever is less; and maintained at a depth of 6".

ILHR 21.27 (3)(a)1. REFERENCE MATERIAL -- ROOFING SHINGLES

The *Residential Asphalt Roofing Manual* can be purchased from the Asphalt Roofing Manufacturers Association at 6000 Executive Boulevard, Suite 201, Rockville, Maryland 20852-3803. This manual contains extensive information about how shingles are manufactured; the importance of adequate roof ventilation; slope limitations; selecting, estimating, and applying roofing materials and accessories; and inspecting and maintaining the finished roof. It includes a recommendation that properly driven and applied nails be utilized as the preferred fastening system for asphalt shingles.

Results of independent testing of various shingles may be indicated on shingle packages, or may be available from either the shingle manufacturer, or the Midwest Roofing Contractors Association at 4840 West 15th Street, Suite 1000, Lawrence, Kansas 66049-3876.

APPENDIX A**CHAPTER ILHR 22
DETERMINATION OF REQUIRED LEVELS OF INSULATION
USING THE ENERGY WORKSHEET**

Two methods may be used to determine the level of insulation required by Chapter ILHR 22 for electrically heated and non- electrically heated dwellings. The Component Method (also known as the Accepted Practice Method) can be used with a minimum of calculations and is recommended for standard designs. The System Design Method is more complex and is used for alternate designs. Under the System Design Method, less insulation may be installed in one building component if more insulation is installed in another.

The following illustration demonstrates use of the Energy Worksheet to determine the required levels of insulation. Single copies of the Energy Worksheet are available at no charge upon written request.

Write to:

Department of Industry, Labor and Human Relations
Division of Safety and Buildings
Post Office Box 7969
Madison, Wisconsin 53707

Portions A and H of the Energy Worksheet must be filled out for the Component Method. Portions B, C and D of the Energy Worksheet must be filled out to use the System Design Method. Sections B and F are filled out to size the furnace for either method. Section G must be filled out to size the ventilation system for electrically heated homes. Both the Component Method and the System Method will be shown in the illustration, although completion of only one method is sufficient to show compliance with the insulation requirements of Ch. ILHR 22.

Sample dwelling: Electrically heated single-family dwelling located in Dane County (Zone 3). Has 1,500 square feet and 186 linear feet of perimeter building thermal envelope. Garage is not heated. The 1,500-square foot basement will be divided into a 575-square foot finished living space and a 925-square foot utility space. The basement ceiling is fully drywalled.

Gross above foundation wall = 8.13 feet (8 feet + 3/4-inch flooring + 3/4-inch ceiling) x 186 linear feet
= 1,512.18 square feet

Wall window area = 150.33 square feet

Door area = 37.82 square feet

Box sill area = 0.81 feet (9-3/4 inches deep: sill, header, subfloor) x 186 linear feet = 150.66 square feet

Foundation wall height = 8 feet

Gross exposed foundation wall area = .67 feet (8 inches) x 186 feet = 124.62 square feet

Foundation wall window area = 8.30 square feet

Ceiling area = 1,500 square feet

Walls

Wood bevel 1/2-inch x 8-inch siding	R = 0.81
1-inch extruded polystyrene sheathing	R = 5.27
R19 Batt insulation	R = 19
2 x 6 framing, 24 inches O.C.	R = 6.875
1/2-inch drywall finish	R = 0.45

Ceiling

2 x 6 framing, 24 inches O.C.	R = 6.875
Blown fiberglass insulation	R/inch = 2.5
Insulation in 5.5-inch cavity	R = 13.75
Insulation over both cavity and framing, 16 inches	R = 40
1/2-inch drywall finish	R = 0.45

Foundation

8-inch masonry block	R = 1.72
2-inch extruded polystyrene	R = 10.54

Windows

All triple glazed with 1/2-inch air spaces, U = .36	R = 2.8
---	---------

Doors

Insulated prime door	R = 2.12
Storm Door	R = 1.00
Total door R value	R = 3.12

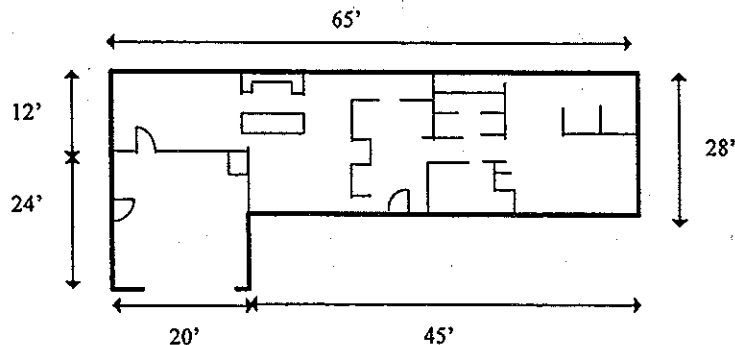

DILHR

Safety and Buildings Division
P.O. Box 7969
Madison, WI 53707

Submit completed worksheet
with dwelling plans to local
enforcing municipality.

ENERGY WORKSHEET UNIFORM DWELLING CODE

PROJECT ADDRESS: _____ SAMPLE - ZONE 3 _____

BUILDER: _____ OWNER: _____

WORKSHEET COMPLETED BY: _____ DATE: _____

Does dwelling unit have three kilowatts or more input capacity of permanently installed electrical space heating equipment?

YES (see below) NO

If yes, then indicate infiltration control option, in addition to basic caulking:

_____ Full sealing per s. ILHR 22.13(3)(a)
 _____ Infiltration barrier per s. ILHR 22.13(3)(b)
 _____ Blower door test per s. ILHR 22.13(2)(c) & (3)(c)

INSTRUCTIONS: This worksheet is a DILHR-approved method of showing compliance with the energy conservation standards of Chapter ILHR 22 of the Uniform Dwelling Code (UDC) which applies to one- and two-family dwellings and their additions built since December 1, 1978. It may be necessary for the user to purchase a copy of the UDC from State Document Sales, (608) 266-3358. Additional information is printed in the UDC Commentary, which is available for \$5.00 from DILHR at the address at the top of this page.

All "R" and "U" calculations must be carried to four places after the decimal point, rounded to three places. Linear dimensions must be carried to three places, rounded to two. Area and heat loss calculations may be rounded to the whole number.

Numbers in brackets, [1], refer to the footnotes printed on page 5.

Single copies of this worksheet are available free from DILHR at the above address. For multiple copies, contact DILHR for fee information. Earlier editions of this worksheet may be used, except that electrically heated dwellings require a worksheet reflecting the higher required U values.

Choice of Method

You have the choice of using the Accepted Practice Method or the System Design Method to show code compliance. For the simpler Accepted Practice Method, which is recommended for standard designs, complete Sections A., B., E., F., and H. You will be first calculating component areas, then your dwelling's code-allowed and other heat loss to determine your needed heating equipment capacity, and then comparing your planned insulation levels to the required insulation levels from the Appendix of the UDC.

For the System Design Method, which is recommended for alternative designs in which more insulation is installed in one component to offset less in another, complete Sections A. through F. You will be first calculating component areas, then the code-allowed heat loss, then component U- and R-values and then your calculated heat loss which you will compare to the code-allowed heat loss. You will also be calculating the allowable heating equipment capacity.

With either method, you will need to apply the stricter and slightly different standards shown for electrically-heated homes if you answered "YES" to the above question. For electrically heated homes, you must also complete Section G. to determine the required mechanical ventilation capacity.

A. AREA CALCULATIONS

Enter appropriate dimensions to obtain area values. Some calculations will not be necessary depending on home design and heating fuel. These calculated areas are referenced elsewhere on this worksheet, for example, A.1., A.2.

<p>1. GROSS (INSULATED) ABOVE-FOUNDATION WALL AREA (Including doors, windows and box sills)</p> <p>8.13 x 186 = 1512 0.81 x 186 = 151</p> <p style="text-align: right;"><u>1663</u> sq. ft.</p>		<p>4. GROSS EXPOSED FOUNDATION WALL AREA</p> <p>a.</p> <p>0.67 x 186 = <u>125</u> sq. ft.</p> <p>Non-Electric Only:</p> <p>b. Multiply A.11. X .25 = _____ sq. ft. c. If A.4.a. is greater than A.4.b., then subtract b. from a. = _____ sq. ft.</p>	
<p>2. WINDOW & PATIO DOOR AREA (sash/door area)</p> <p>a. In Above-Foundation Walls b. In Foundation Walls</p> <p><u>150</u> sq. ft. <u>8</u> sq. ft.</p> <p>Total (a. + b.) = <u>158</u></p>		<p>5. FOUNDATION WALL AREA BETWEEN GRADE AND THREE FEET BELOW GRADE</p> <p>3 x 186 = <u>558</u> sq. ft.</p>	
<p>3. DOOR AREA IN ABOVE-FOUNDATION WALLS</p> <p style="text-align: right;"><u>38</u> sq. ft.</p>		<p>6. FOUNDATION WALL AREA MORE THAN THREE FEET BELOW GRADE</p> <p>8' - 0.67' - 3.0' = 4.33'</p> <p>4.33' x 186 = <u>805</u> sq. ft.</p>	
<p>7. OPAQUE [1] ABOVE-FOUNDATION WALL AREA (A.1.-A.2.a.-A.3.)</p> <p>1663 <u>-173</u></p> <p>=<u>1452</u> sq. ft.</p>	<p>8. GROSS WALL AREA ABOVE GRADE (A.1. + A.4.a.) (Electric only)</p> <p>1663 <u>+125</u></p> <p>=<u>1788</u> sq. ft.</p>	<p>9. OPAQUE [1] EXPOSED FOUNDATION WALL AREA (A.4.a.-A.2.b.)</p> <p>125 <u>-16</u></p> <p>=<u>109</u> sq. ft.</p>	
<p>10. WALL AREA BELOW GRADE (A.5. + A.6.)</p> <p>558 <u>+805</u></p> <p>= <u>1363</u> sq. ft.</p>	<p>11. TOTAL FOUNDATION WALL AREA (A.4.a. + A.5. + A.6.) (Non-Electric)</p> <p>125 <u>+558</u></p> <p>= <u>1488</u> sq. ft.</p>	<p>12. INSULATED ROOF OR CEILING AREA</p> <p>28 x 45 = 1260 12 x 20 = <u>240</u></p> <p>= <u>1500</u> sq. ft.</p>	
<p>13. FLOOR AREA OVER UNHEATED SPACES (Less Than 50°)</p> <p>_____ sq. ft.</p>	<p>14. SLAB ON GRADE</p> <p>_____ lineal feet of slab perimeter</p>	<p>15. BASEMENT FLOOR AREA</p> <p style="text-align: right;"><u>1500</u> sq. ft.</p>	

B. CODE-ALLOWED HEAT LOSS

Enter area values from Section A as notated and temperature differences per footnote 2 into this table and then multiply across by the electric or non-electric code-required U-value. Total the right column to find the total allowed heat loss.

COMPONENT	AREA FROM SECT. A	REQUIRED U-VALUE		TEMP DIFFERENCE [2]	HEAT LOSS BTU/HR
		<input type="checkbox"/> NON-ELEC	<input checked="" type="checkbox"/> ELECTRIC		
1. Gross Wall Above Grade (A.8.)(electric only)	1788	N/A	.080	85	12,158
2. Gross Above-Foundation Wall (A.1.)(non-elec)		.12	N/A		
3. Gross Exposed Foundation Wall (non-elec)		.25	N/A		
a. Lesser of Area A.4.a. or A.4.b.		.12	N/A		
b. Area A.4.c. (if any)					
4. Foundation Wall Between Grade And 3 Feet Below Grade (A.5.)	558	.113 [3]	.072 [3]	60	2,411
5. Foundation Wall More Than Three Feet Below Grade (A.6.)	805	.094 [3]	.048 [3]	60	2,318
6. Floors Over Unheated Spaces (A.13.)		.09	.055		
7. Roof or Ceiling (A.12.)	1,500	.029	.020	85	2,550
8. Slab On Grade (A.14.)	Lin. ft.	.51 'F' [4]	.51 'F' [4]		
9. Basement Floor (A.15.)	1500	.025	.025	60	2,250
TOTAL CODE - ALLOWED HEAT LOSS					21,687

C. SYSTEM DESIGN METHOD - ACTUAL 'U' VALUES OF YOUR HOME'S COMPONENTS

C.1. ABOVE-GRADE COMPONENTS - If applicable, check the appropriate typical component constructions listed below, and use the pre-calculated U values. If your wall construction is not listed, you may be able to obtain a pre-calculated U value from Table E-2 of the UDC Appendix. If your component construction is not listed here or in Table E-2, you will need to enter R-values for the different layers of building materials from Table A-4 of the UDC Appendix, ASHRAE Fundamentals Manual or manufacturer's specifications. Total them across and then determine the U-value by taking the reciprocal (1/R) of the total R-value.

COMPONENT	CAVITY OR SOLID IF APPLICABLE	EXT. AIR FILM *	EXT. FINISH	SHEATHING	INSULATION OVER FRAMING	FRAMING OR SOLID	INSULATION WITHIN CAVITY	INTERIOR FINISH	INT. AIR FILM	TOTAL 'R-VALUE'	'U-VALUE'
Above-Foundation Walls	Cavity	.17	0.81	5.27			19	0.45	.68	26.38	0.038
	Solid	.17	0.81	5.27		6.88		0.45	.68	14.26	0.070
<input type="checkbox"/> 2X4, 16" O.C., R-11 batt, R-1 board: U - .081 <input type="checkbox"/> 2X4, 16" O.C., R-11 batt, R-5 board: U - .060 <input type="checkbox"/> 2X6, 16" O.C., R-19 batt, R-1 board: U - .055 <input type="checkbox"/> 2X6, 16" O.C., R-19 batt, R-5 board: U - .044 <input type="checkbox"/> Other - describe: _____ U - _____ from Table E-2											
Exposed Foundation	Cavity	.17							.68		
	Solid	.17		10.54		1.72			.68	13.11	0.076
<input type="checkbox"/> Masonry or concrete wall without insulation: U - 1.0 <input type="checkbox"/> Masonry or concrete wall with R-5 insulation: U - .167 <input type="checkbox"/> Masonry or concrete wall with R-10 insulation insulation board or R-11 insulation batt and 2X4s: U - .091 <input type="checkbox"/> Other - describe: _____ U - _____ from Table E-2											
Roof or ceiling	Cavity	.61							.61		
	Solid	.61							.61		
<input type="checkbox"/> 2X4 truss, 24" O.C., with R-38 insulation: U - .029 <input checked="" type="checkbox"/> 2X4 truss, 24" O.C., with R-52 insulation: U - .020 <input type="checkbox"/> 2X12 cathedral ceiling, 16" O.C., with R-38 insulation: U - .027											
Floor Over Unheated Space	Cavity	.17							.92		
	Solid	.17							.92		
<input type="checkbox"/> 2X10 joists, 16" O.C., R-19 batt: U - .045											

* Air Film R-Values

LOCATION	HEAT FLOW DIRECTION		
	Upwards	Horizontal	Downwards
EXTERIOR	.17	.17	.17
INTERIOR	.61	.68	.92

C.2. BELOW-GRADE AND SLAB-ON-GRADE COMPONENTS - Check appropriate boxes for planned type of construction to determine precalculated overall 'U-value' including air films, wall, insulation, soil and cavity/solid differences. Slab on grade F-values are per lineal foot of slab perimeter.

COMPONENT TYPE	GRADE TO THREE FEET BELOW GRADE	MORE THAN THREE FT. BELOW GRADE
<input type="checkbox"/> Masonry or concrete wall without insulation	.288	.094
<input type="checkbox"/> Concrete block with insulated cores	.113	.063
<input type="checkbox"/> Masonry or concrete wall with R-5 insulation board	.113	.063
<input type="checkbox"/> Masonry or concrete wall with R-10 insulation board or R-11 insulation batt and 2x4's	.072	.048
<input type="checkbox"/> Permanent wood foundation with R-19 batt	.043	.034
<input type="checkbox"/> Basement floor without insulation	.025	.025
<input type="checkbox"/> Basement floor with R-5 insulation	.022	.022
<input type="checkbox"/> Other (describe)		
SLAB-ON-GRADE (or within 2 feet of grade)	UNHEATED SLAB	HEATED SLAB
<input type="checkbox"/> Slab-on-grade without insulation	.81 (F-value)	2.73 (F-value)
<input type="checkbox"/> Slab-on-grade with R-5 insulation for 48" total horizontal and vertical application	.56 (F-value)	.90 (F-value)
<input type="checkbox"/> Slab-on-Grade with R-10 insulation board for 48" total application	.51 (F-value)	.82 (F-value)

C.3. WINDOWS AND DOORS - See Tables A-5 and A-6 of UDC Appendix for U-values. You may use manufacturer's specifications for window and glazed door values if they are per NFRC Std 100 or Window 3.1.

D. SYSTEM DESIGN METHOD - CALCULATED ENVELOPE HEAT LOSS OF YOUR HOME

Enter values into table from elsewhere on this worksheet and multiply across to find the actual heat loss of each component. If using precalculated component U-values, do not calculate cavity and solid figures or apply wood frame factors. Total component heat loss figures in right column to find total envelope heat loss.

COMPONENT	CAVITY OR SOLID IF APPLICABLE	AREA FROM SECT. A.	X	WOOD FRAME FACTOR **	X	ACTUAL 'U' VALUE FROM SECT. C.	X	TEMP DIFFERENCE (2)	=	HEAT LOSS BTU/HR
Opaque Above-Foundation Wall (A. 7.)	Cavity	1452		0.78		0.038		85		3658
	Solid			0.22		0.070			1900	
Opaque Exposed Foundation Wall (A. 9.)	Cavity	109				0.076		85		704
	Solid									
Foundation Between Grade and Three Feet Below Grade (A. 5.)	Cavity	558				0.072		60		2411
	Solid									
Foundation Wall More Than Three Feet Below Grade (A. 6.)	Cavity	805				0.048		60		2318
	Solid									
Above-Foundation Windows (A. 2. a.)		158				0.360		85		4834
Foundation Windows (A.2.b.)										
Doors (A.3.)		38				0.321		85		1037
Roof or Ceiling (A. 12.)	Cavity	1500				0.20		85		2550
	Solid									
Floor Over Unheated Spaces (A. 13.)	Cavity									
	Solid									
Basement Floor (A. 15.)	Cavity	1500				0.025		60		2250
	Solid									
Slab On Grade (A. 14.)			Lin. ft.			F-Val.				
TOTAL CALCULATED ENVELOPE HEAT LOSS - May not exceed Total Code Allowed Heat Loss in Sect. B. by more than 1%										21,662

** Adjustment Factors For Wood-Framed Components

SPACING OF FRAMING MEMBERS	STUD WALLS		JOISTS/RAFTERS	
	CAVITY	SOLID	CAVITY	SOLID
12"	.70	.30	.86	.14
16"	.75	.25	.90	.10
24"	.78	.22	.93	.07

Also see Part C of UDC Appendix Table A-5 for window framing adjustment factors.

E. HEAT LOSS BY AIR INFILTRATION (for furnace sizing)

Enter appropriate values. An air change rate of between 0.25 and 1.00 per hour is recommended depending on tightness of construction.

FLOOR LEVEL	AREA	X	HEIGHT	=	VOLUME	X	CONSTANT	X	TEMPERATURE DIFFERENCE [2]	X	AIR CHANGES PER HOUR	=	HEAT LOSS BTU/HR
Basement	1500		8		12,000		.018		85		5		9180
Level 1	1500		8		12,000		.018		85		5		9180
Level 2							.018						
Level 3							.018						
Total Conditioned Dwelling Volume					24,000	INFILTRATION HEAT LOSS					18,360		

F. HEATING EQUIPMENT SIZING

Enter appropriate value to determine the maximum and minimum allowable heating equipment capacity in BTU's/HR. [5]

	Minimum	Maximum
System Design Method: Calculated Heat Loss from Sect. D. or Accepted Practice Method: Code-Allowed Heat Loss from Sect. B.	21,662	-----
Code-Allowed Heat Loss (from Sect. B.)	-----	21,687
Infiltration Heat Loss (from Sect. E.)	+ 18,360	+ 18,360
TOTAL DWELLING HEAT LOSS (total of above)	= 40,022	= 40,047
Allowable Heating Equipment Size Margin Multiplier	X 1.0	X 1.15
ALLOWABLE HEATING EQUIPMENT OUTPUT SIZE RANGE	= 40,022	= 46,054 [6]
Planned Furnace Output Or Boiler IBR Rating	50,000	

G. MECHANICAL VENTILATION SIZING

For electrically heated dwellings only, enter appropriate values to determine minimum cubic feet per minute (CFM) fan output to meet one-half air exchange per hour requirement.

1. Dwelling volume from Sect. E.	=	24,000
2. Less volume of non-living area: area: (925) X height: (8)	=	- 7,400
3. Less volume of dead air spaces (cabinets, walls, etc - approx. 20% of living space volume)	=	- 3,400
4. Net volume of living area (total of above)	=	13,200
5. Minimum cubic feet of air changed per hour (multiply line 4 by 0.5)	=	6,600
6. MINIMUM REQUIRED MECHANICAL VENTILATION IN CFM's (divide line 5 by 60)	=	110

Footnotes:

- [1] Opaque wall area is wall area minus opening areas of doors and windows.
- [2] Temperature Difference = Inside design temperature of 70° minus outside design temperature from Table 22.04-B of the UDC. Basement inside temperature may be taken between 50° and 70°. Temperature difference for transmission heat losses only (not infiltration losses) of below-grade spaces of basements is inside temperature minus 10°, disregarding outside temperature. If the basement ceiling is insulated, then the basement is considered unheated and the heat loss from the above heated space through the basement ceiling should be calculated using an outside temperature of 45°.
- [3] These below-grade U-values have the insulating value of the soil added to the code-required U-values which apply to the building materials only. See sect. C.2. for typical insulated component U-values.
- [4] These slab-on-grade F-values are derived from the code-required U-values and include the heat loss through the edge and body of the slab. See sect. C.2. Temperature difference is the same as for above-grade spaces.
- [5] For building additions, show that the existing heating equipment, if used to also heat the addition, is large enough. To do so, you must calculate the heat loss of the whole building.
- [6] If desired manufacturer does not have a furnace of this size, then a designer may select the manufacturer's next larger size.

H. ACCEPTED PRACTICE METHOD

For completion of the accepted practice method, please refer to the Appendix Tables A-1, 2 and 3 and E-1, 2 and 3 of the Uniform Dwelling Code (UDC). Complete Subsection H.1. if your home is heated with other than electricity. Complete Subsection H.2. if your home is electrically heated. Area figures should be calculated in Section A. and are referenced below.

SUBSECTION H.1. Non-Electrically Heated Homes Only

<p>WALLS ABOVE FOUNDATION WALL INCLUDING BOXSILL, USE TABLE A-1</p>	<p>MINIMUM ABOVE-FDTN WINDOWS: <input type="checkbox"/> Single w/storm <input type="checkbox"/> Insulated glass <input type="checkbox"/> Triple pane</p> <p>MINIMUM DOORS: <input type="checkbox"/> Insulated <input type="checkbox"/> Solid Wood <input type="checkbox"/> Uninsulated w/storm</p> <p>SIDING: <input type="checkbox"/> Wood (R- .77) <input type="checkbox"/> Alum. (R- 1.82) <input type="checkbox"/> Other: R- _____</p> <p>PLANNED INSULATION TYPE AND R-VALUE: _____</p> <p>PERMITTED WINDOW AND DOOR AREA: _____ %</p> <p>$\frac{\text{Above Foundation Window \& Door Area (A.2.a. + A.3.)}}{\text{Gross Above-Foundation Wall Area (A.1.)}} \times 100\% = \text{_____ \% Planned Window and Door Area}$</p>
<p>EXPOSED FOUNDATION WALL, USE TABLE A-2</p>	<p>BASEMENT WINDOWS: <input type="checkbox"/> Single-glazed OR <input type="checkbox"/> Single w/storm or insulated glass</p> <p>PLANNED INSULATION TYPE AND R-VALUE: _____</p> <p>If no number entered in A.4.c., then enter Percent Permitted Window Area from Table A-2, $U_o = .25$: _____ %</p> <p>If number entered in A.4.c., then calculate:</p> <p>$\left[\left(\frac{\text{Area A.4.b.} \times \text{\% Window from Table A-2, } U_o = .25}{\text{Area A.4.c.} \times \text{\% Window from Table A-2, } U_o = .12} \right) + \left(\frac{\text{\% Window from Table A-2, } U_o = .25}{\text{\% Permitted Window Area}} \right) \right] \div \frac{\text{Area A.4.a.}}{\text{\% Permitted Window Area}} = \text{_____ \%}$</p> <p>$\frac{\text{Basement Window Area (A.2.b)}}{\text{Exposed Fndtn. Wall Area (A.4.a.)}} \times 100\% = \text{_____ \% Planned Window Area}$</p>
<p>ROOF OR CEILING, USE TABLE A-3</p>	<p>PLANNED INSULATION TYPE: _____ R-VALUE PER INCH: _____</p> <p>REQUIRED THICKNESS: _____ Inches in cavity (R-38) _____ Inches Over Framing (R-19)</p>
<p>FOUNDATION WALL, GRADE TO 3 FEET DOWN</p>	<p>PLANNED INSULATION TYPE AND R-VALUE: _____ (MINIMUM R-5 INSULATION)</p>

Completed for demonstration purposes. Normally only complete the system design method or accepted practice method.

SUBSECTION H.2. Electrically Heated Homes Only

<p>WALLS ABOVE FOUNDATION INCLUDING BOX-SILL, USE TABLES E-1 AND E-2</p>	<p>ALL THESE MEASURES REQUIRED: <input type="checkbox"/> ALL WINDOWS TRIPLE-GLAZED <input type="checkbox"/> EXPOSED FOUNDATION INSULATED TO R-10.54 <input type="checkbox"/> DOORS INSULATED TO R-8</p> <p>$\frac{189}{\text{Total Window Area (A.2.a. + b.)}} \div \frac{1788}{\text{Above Grade Wall Area (A.8.)}} \times 100\% = \frac{10.6}{\text{\% Window Area}}$</p> <p>$\frac{109}{\text{Opaque Exposed Foundation Area (A.9.)}} \div \frac{1788}{\text{Above-Grade Wall Area (A.8.)}} \times 100\% = \frac{6.1}{\text{\% Opaque Exposed Foundation Wall}}$</p> <p>REQUIRED ABOVE FOUNDATION WALL U-VALUE (FROM TABLE E-1): <u>.044</u></p> <p>PLANNED WALL CONSTRUCTION: <u>2 x 6 24" o.c. foamboard R-19 batt, R5U-27</u> U-VALUE FROM TABLE E-2: <u>.043</u></p>
<p>ROOF OR CEILING, USE TABLE E-3</p>	<p>PLANNED INSULATION TYPE: <u>blown fiberglass</u> R-VALUE PER INCH: <u>2.5</u></p> <p>REQUIRED THICKNESS FROM TABLE E-3: <u>20.0</u> Inches</p>
<p>FOUNDATION WALL FOR FULL HEIGHT</p>	<p>PLANNED INSULATION TYPE AND R-VALUE: <u>2" XEPS R10.5</u> (MINIMUM R-10 INSULATION)</p>

TABLE A-1
WALL INSULATION GUIDE

(Based on U_o requirements above the foundation wall for non-electrically heated dwellings)

INSULATION TYPE	MAXIMUM PERCENT WINDOW AND DOOR AREA ALLOWABLE FOR INSULATION TYPE	
	$U_o = .12$	
	% inch Plywood Siding	Backed Aluminum Siding
R-11 Batt	6.8	8.4
R-11 Batt, R-1.22 Fiberboard	8.7	9.9
R-11 Batt, R-5.27 Extruded Polystyrene	12.4	13.0
R-11 Batt, R-10.54 Extruded Polystyrene	14.9	15.3
R-13 Batt	8.3	9.8
R-13 Batt, R-1.22 Fiberboard	10.3	11.2
R-13 Batt, R-5.27 Extruded Polystyrene	13.1	13.6
R-13 Batt, R-10.54 Extruded Polystyrene	15.3	15.6
R-19 Batt	11.2	12.2
R-19 Batt, R-1.22 Fiberboard	12.3	13.1
R-19 Batt, R-5.27 Extruded Polystyrene	14.7	15.1
R-19 Batt, R-10.54 Extruded Polystyrene	16.3	16.6

Note: The following assumptions were used to derive this table:
 1. Door area = 2% of wall and box sill area.
 2. Doors are used with a U-value of 0.47.
 3. Windows are used with a U-value of 0.56.
 4. The insulation type is carried down through the box sill.

TABLE A-2
EXPOSED FOUNDATION INSULATION NON-ELECTRICALLY HEATED DWELLINGS

Foundation Exposure	Requirement	Insulation Type	Maximum Percent Window Area	
			Single glazed	Double glazed
Less than 25% of foundation exposed	$U_o = .25$	R-5.27	10.4	24.8
		R-11 batt	15.5	34.2
		Multi-cell insul. block (R-12.06)	16.0	35.0
More than 25% of foundation exposed	$U_o = .13$	R-11 batt	3.9	8.7
		R-13 batt	4.8	10.6
		Multi-cell insul. block (R-12.06)	4.5	9.9
	$U_o = .12$	R-11 batt	3.0	6.7
		R-13 batt	3.9	8.5
		Multi-cell insul. block (R-12.06)	3.5	7.8

TABLE A-3
INSULATION LEVELS REQUIRED TO MEET CEILING U VALUES FOR NON-ELECTRICALLY HEATED DWELLINGS

U_o Value	Insulation	R-Value Required	
		In Cavity	Over Framing
.029	Fiber glass batt	R-38	R-19
	Fiber glass blown	13.6 in. (R-34)	8.1 in. (R-20)
	Rock wool	10.9 in. (R-33)	5.4 in. (R-16)
	Cellulose	9.5 in. (R-35)	4.0 in. (R-15)

Note: The following assumptions are used:
 1. Fiber glass blown = R-2.5 per inch
 2. Rock wool = R-3.0 per inch
 3. Cellulose = R-3.7 per inch

TABLE E-1 - DIRECTIONS FOR USE

Table E-1 was formulated with the following assumptions:

The doors have R-values of at least R-8 and form 2% or less of the above-foundation wall.

$$\frac{\text{door area}}{\text{gross wall area} + \text{box sill}} \times 100\%, \text{ in this case} =$$

$$\frac{37.82}{1512.18 + 150.66} \times 100\% = 2\%$$

Windows with an R-value of at least 2.7 (triple glazed) are used, including the foundation windows.

The exposed foundation area is insulated to a level of R-10.54.

If these assumptions are not valid for your case, the insulation level may be calculated by the method illustrated following Tables E-1 and E-2.

TABLE E-1
MAXIMUM ABOVE-FOUNDATION WALL U-VALUES FOR ELECTRICALLY HEATED HOMES
PERCENT WINDOW AREA

	5	6	7	8	9	10	11	12	13	14	15	16
	.065	.062	.059	.056	.053	.050	.046	.043	.040	.036	.032	.029
	.065	.061	.058	.055	.051	.048	.044	.041	.037	.033	.029	.025
PERCENT	.064	.061	.058	.055	.051	.048	.044	.040	.037	.033	.029	.025
	.064	.061	.058	.054	.051	.047	.044	.040	.036	.032	.029	.025
	.064	.061	.057	.054	.050	.047	.043	.039	.035	.031	.027	
OPAQUE	.064	.060	.057	.053	.050	.046	.042	.038	.034	.030	.026	
	.064	.060	.057	.053	.049	.046	.042	.038	.034	.030	.025	
FOUNDA-	.063	.060	.056	.053	.049	.045	.041	.037	.033	.029	.025	
	.063	.060	.056	.052	.049	.045	.041	.037	.033	.028		
	.063	.059	.056	.052	.048	.044	.040	.036	.032	.027		
TION	.063	.059	.055	.052	.048	.044	.040	.036	.031	.027		
	.063	.059	.055	.051	.047	.043	.039	.035	.031	.026		
	.062	.059	.055	.051	.047	.043	.039	.034	.030	.025		
AREA	.062	.058	.055	.051	.047	.042	.038	.034	.029			
	.062	.058	.054	.050	.046	.042	.037	.033	.028			
	.062	.058	.054	.050	.046	.041	.037	.032	.028			
	.061	.057	.053	.049	.045	.041	.036	.032	.027			
	.061	.057	.053	.049	.045	.040	.036	.031	.026			
	.061	.057	.053	.048	.044	.040	.035	.030	.025			
	.061	.057	.052	.048	.044	.039	.034	.029				
	.060	.056	.052	.048	.043	.038	.034	.029				

TABLE E-2
FRAME WALL & BOX SILL U-VALUES FROM DIFFERENT
BUILDING MATERIALS AND METHODS

Insulation Type	2 x 4 FRAMING 16" O.C. ¹	2 x 6 FRAMING 16" O.C.	2 x 6 FRAMING 24" O.C. ²	Double 2 x 4 or 2 x 8 FRAMING 24" O.C.
R-11 Batt	0.091			
R-11 Batt, R1.22 Fiberboard	0.081			
R-11 Batt, R5.27 Polystyrene	0.060			
R-11 Batt, R10.54 Polystyrene	0.045			
R-11 Batt, R7.21 Isocyanurate	0.054			
R-11 Batt, R14.4 Isocyanurate	0.038			
R-13 Batt	0.083			
R-13 Batt, R1.22 Fiberboard	0.074			
R-13 Batt, R5.27 Polystyrene	0.056			
R-13 Batt, R10.54 Polystyrene	0.043			
R-13 Batt, R7.21 Isocyanurate	0.050			
R-13 Batt, R14.4 Isocyanurate	0.036			
R-19 Batt		0.060		
R-19 Batt, R1.22 Fiberboard		0.055	0.058	0.056
R-19 Batt, R5.27 Polystyrene		0.044	0.053	0.052
R-19 Batt, R10.54 Polystyrene		0.036	0.043	0.042
R-19 Batt, R7.21 Isocyanurate		0.040	0.035	0.034
R-19 Batt, R14.4 Isocyanurate		0.031	0.039	0.039
			0.030	0.030

Insulation Type	2 x 4 FRAMING 16" O.C. ¹	2 x 6 FRAMING 16" O.C.	2 x 6 FRAMING 24" O.C. ²	Double 2 x 4 or 2 x 8 FRAMING 24" O.C.
Two R-11 Batts				0.053
Two R-11 Batts, R1.22 Fiberboard				0.049
Two R-11 Batts, R5.27 Polystyrene				0.040
Two R-11 Batts, R10.54 Polystyrene				0.033
Two R-11 Batts, R7.21 Isocyanurate				0.037
Two R-11 Batts, R14.4 Isocyanurate				0.029
Two R-13 Batts				0.048
Two R-13 Batts, R1.22 Fiberboard				0.045
Two R-13 Batts, R5.27 Polystyrene				0.037
Two R-13 Batts, R10.54 Polystyrene				0.030
Two R-13 Batts, R7.21 Isocyanurate				0.034
Two R-13 Batts, R14.4 Isocyanurate				0.027

¹Assumes 20% framing, 80% cavity.

²Assumes 17% framing, 83% cavity.

MANUAL CALCULATION METHOD

To calculate the required wall U-value without using Tables E-1 and E-2, use the method outlined below:

Step 1: Calculate the above grade wall composition.

% Window area = 10.53%

% Door area = 2.12%

% Opaque foundation area = 6.10%

% Opaque wall & box sill area = 82.25%

Step 2: Use the following formula to calculate the maximum allowable U-value for the opaque wall and box sill.

$$U_o - (U_w \times \%w) - (U_d \times \%d) - (U_f \times \%f) = U_{wall}$$

%wall

Where:

- U_o = Required overall above grade wall U-value, use 0.080 for an electrically heated home
- U_w = The U-value of the windows (= 1/R-value)
- $\%w$ = The fraction of window area calculated in Step 1
- U_d = The U-value of the doors (= 1/R-value)
- $\%d$ = The fraction of door area calculated in Step 1
- U_f = The U-value of the insulated foundation
- $\%f$ = The fraction of exposed foundation calculated in Step 1
- $\%wall$ = The fraction of opaque wall and box sill area as calculated in Step 1
- U_{wall} = The maximum U-value of the opaque wall and box sill to be calculated

In our example:

The window R-value = R-2.78 $U = 1/2.78 = 0.341$

The door R-value = R-8.85 $U = 1/8.85 = 0.113$

The foundation R-value = R-12.4 $U = 1/12.4 = 0.080$

$$U_{wall} = \frac{0.080 - (0.341 \times 0.1053) - (0.113 \times 0.0212) - (0.080 \times 0.0610)}{0.8225} = 0.045$$

In this case, the maximum U-value of the opaque wall and box sill is 0.045 Btu/hr. sq. ft. °F. For compliance, the insulation which is installed in the wall and box sill must provide a U-value which is less than or equal to 0.045. Table E-3 shows the U-values obtainable from different insulation materials and framing types.

TABLE E-3 DIRECTIONS FOR USE

Table E-3 gives the amount of installed insulation which would be necessary to achieve a required U-value in the ceiling or attic.

Table E-3 was formulated with the following assumptions:

- The loose fill insulation, if used, is installed to provide the following R-values:

Cellulose	R = 3.7/in
Expanded perlite	R = 2.7/in
Mineral Fiber (rock, slag, or glass)	R = 3.3/in
Polystyrene beads	R = 2.9/in
Fiber glass, blown	R = 2.5/in
- The insulated area is 90% cavity and 10% 2 × 6 framing
- There are no skylights in the ceiling/attic assembly
- The R-value of the ceiling finish materials plus air films is R-1.2
- The attic hatch is insulated to the same level as the rest of the attic floor, if it is a part of the thermal envelope.

If these assumptions are not valid for your case, you may calculate the required U-value as shown after Table E-3.

TABLE E-3
INSULATION LEVELS REQUIRED TO MEET CEILING U_o VALUES

Dwelling Fuel Type	U_o	Insulation Type	Amount Required In Cavity Depth (R-Value)
Electrically Heated	0.020	Fiber glass Batts	R-54
		Cellulose	14.1 in. (R-52)
		Expanded Pearlite	18.6 in. (R-50)
		Mineral Fiber	15.6 in. (R-51)
		Polystyrene Beads	17.5 in. (R-52)
		Blown Fiber glass	20.0 in. (R-50)

MANUAL CALCULATION METHOD

To calculate the required ceiling insulation level for ceiling/attic assemblies, use the following method.

Step 1: Calculate the required U-value for the attic floor, U_F , with the following formula.

$$U_F = \frac{U_o A_o - U_s A_s - U_h A_h}{A_F}$$

Where:

- U_F = The required U-value for the attic floor
- U_o = The overall U-value set by the code, use 0.020 for an electrically heated dwelling
- A_o = The overall attic/ceiling area including the attic floor, any skylights and the attic hatch or access panel
- U_s = The U-value of the skylights including the frame
- A_s = The area of skylights, including the frame (if there are no skylights, set equal to zero)
- U_h = The U-value of the attic hatch or access panel
- A_h = The area of the attic hatch or access panel (If the hatch is to be insulated to the same level as the attic floor, add the area to the floor area, A_F , and set A_h equal to zero. If the attic hatch or access panel is not a part of the thermal envelope, set A_h equal to zero.)
- A_F = The area of the insulated attic floor, equal to the overall attic/ceiling area minus the attic hatch and skylight areas, if any.

ILHR 20-25 Appendix

Example: For the attic of an electrically heated dwelling with an overall attic area of 1500 sq. ft. The attic hatch is 14"C24" and is to be insulated with two R-19 fiber glass batts, the rest of the attic is to be insulated with blown mineral fiber with an R-value of 3.3-R/inch. There are two skylights, each 6 square feet with R-values of 1.8.

The R-value of the attic hatch is the sum of the R-values of the batts plus R-2 for the finish materials and air films.

$$R = 19 + 19 + 2 = 40$$

The U-value of the hatch is $U_h = 1/40 = 0.025$

The U-value of the skylights $U_s = 1/1.8 = 0.56$

The area of the hatch = 2 ft x 1.17 ft = 2.3 sq. ft.

The area of the skylights is 12 square feet

The area of the floor is 1500 - 12 - 2.3 = 1486 sq. ft.

$$U_F = \frac{(0.020)(1500) - (0.56)(12) - (0.025)(2.3)}{1486} = 0.0156$$

Step #2: To calculate the amount of insulation needed over the framing and cavity areas, d, of the attic floor use the following formula:

$$d = \frac{1}{U_F (R/in)} - \frac{(RW/in) h}{(\%C)(RW/in) + (\%W)(R/in)} - \frac{R_{fin} + h}{(R/in)}$$

Where:

- d = depth of insulation at cavity in inches
- U_F = required U-value of floor calculated in Step #1
- R/in = R-value per inch of insulating material obtained from manufacturer or Table A-4
- h = height of framing, 5-1/2" for 2 x 6 framing or 7-1/4" for 2 x 8 framing, for example.
- %C = fraction of floor which is cavity (usually assume 0.9)
- %W = fraction of floor which is framing (usually assume 0.1)
- RW/in = R-value per inch of wood framing (usually assume 1.25 R/inch)
- R_{fin} = R-value of interior ceiling finish materials, including air films (usually assume R-1.2)

$$d = \frac{1}{(0.0156)(3.3)} + 5.5 - \frac{(1.25)(5.5)}{(0.9)(1.25) + (0.1)(3.3)} - \frac{1.2}{3.3} = 19.59 \text{ inches}$$

The floor of the attic is to be covered with insulation so that the depth in the cavities is equal to 19.59 inches.

TABLE A-4
COMMON CONSTRUCTION MATERIAL R-VALUES*

Material	Description	Density (lb per cu ft)	Per inch	For thick-	
			thickness R-Value	ness listed R-Value	
BUILDING	Asbestos-cement board.....	120	0.25	—	
BOARD Boards,	Asbestos-cement board.....	120	—	0.03	
panels,					
subflooring,					
sheathing, woodbased	Asbestos-cement board.....	120	—	0.06	
panel products	Gypsum or plaster board.....	50	—	0.32	
	Gypsum or plaster board.....	50	—	0.45	
	Plywood.....	34	1.25	—	
	Plywood.....	34	—	0.31	
	Plywood.....	34	—	0.47	
	Plywood.....	34	—	0.62	
	Plywood or wood panels.....	34	—	0.93	
	Insulating board				
	Sheathing, reg. density.....	18	—	1.32	
	18	—	2.06	
	Sheathing, intermediate density.....	22	—	1.22	
	Nail-base				
	sheathing.....	25	—	1.14	
	Shingle backer.....	18	—	0.94	

Material	Description	Density (lb per cu ft)	Per inch	For thick-	
			thickness R-Value	ness listed R-Value	
	Shingle backer	5/16 in.	18	—	0.78
	Sound deadening board	1/2 in.	15	—	1.35
	Tile and lay-in panels, plain or acoustic	1/2 in.	18	2.50	—
	1/2 in.	18	—	1.25
	1/2 in.	18	—	1.89
	Laminated paperboard		30	2.00	—
	Homogeneous board from repulped paper		30	2.00	—
	Hardboard				
	Medium density siding	7/16 in.	40	—	0.67
	Other medium density		50	1.37	—
	High density, underlay		55	1.22	—
	High density std. tempered		63	1.00	—
	Particleboard				
	Low density		37	1.85	—
	Medium density		50	1.06	—
	High density		62.5	0.85	—
	Underlayment	1/2 in.	40	—	0.82
	Wood subfloor	1/2 in.	—	—	0.94
BUILDING PAPER	Vapor-permeable felt		—	—	0.06
	Vapor-seal, 2 layers of mopped 15 lb. felt		—	—	0.12
	Vapor-seal, plastic film		—	—	Negl.
ROOF INSULATION	Preformed, for use above deck				
	Approximately	1/2 in.	—	—	1.39
	Approximately	1 in.	—	—	2.78
	Approximately	1 1/2 in.	—	—	4.17
	Approximately	2 in.	—	—	5.56
	Approximately	2 1/2 in.	—	—	6.67
	Approximately	3 in.	—	—	8.33
	Cellular glass		9	2.50	—
MASONRY MATERIALS	Cement mortar		116	0.20	—
Concrete	Gypsum-fiber concrete				
	87% gypsum, 12% wood chips		51	0.60	—
	Lightweight aggregates		120	0.19	—
	including expanded shale,		100	0.28	—
	clay or slate, expanded		80	0.40	—
	slags; cinders; pumice;		60	0.59	—
	vermiculite; also cellular		40	0.86	—
	concretes		30	1.11	—
		20	1.43	—
	Perlite		40	1.08	—
		30	1.41	—
		20	2.00	—
	Sand and gravel or stone aggregate (oven dried)		140	0.11	—
	Sand and gravel or stone aggregate (not dried)		140	0.08	—
	Stucco		116	0.20	—
MASONRY UNITS	Brick, common		120	0.20	—
	Brick, face		130	0.11	—
	Clay tile, hollow:				
	1 cell deep	3 in.	—	—	0.80
	1 cell deep	4 in.	—	—	1.11
	2 cells deep	6 in.	—	—	1.52
	2 cells deep	8 in.	—	—	1.85
	2 cells deep	10 in.	—	—	2.22
	3 cells deep	12 in.	—	—	2.50
	Concrete blocks, 3 oval core:				
	Sand & gravel aggregate	4 in.	—	—	0.71
	8 in.	—	—	1.11
	12 in.	—	—	1.28
	Cinder aggregate	3 in.	—	—	0.86
	4 in.	—	—	1.11
	8 in.	—	—	1.72
	12 in.	—	—	1.89
	Lightweight aggregate(expanded				
	shale, clay, slate		3 in.	—	1.27
	or slag; pumice)		4 in.	—	1.50
		8 in.	—	2.00
		12 in.	—	2.27
	Concrete blocks, rectangular core				
	Sand & gravel aggregate				
	2 core, 8" 36 lb		—	—	1.04
	Same with filled cores		—	—	1.93
	Lightweight aggregate (expanded shale, clay,				
	slate or slag, pumice):				
	3 core, 6" 19 lb		—	—	1.65
	Same with filled cores		—	—	2.99

Material	Description	Density (lb per cu ft)	Per inch	For thick-
			thickness R-Value	ness listed R-Value
	2 core, 8" 24 lb	—	—	2.18
	Same with filled cores	—	—	5.03
	3 core, 12" 38 lb	—	—	2.48
	Same with filled cores	—	—	5.82
	Stone, lime or sand	—	0.08	—
	Gypsum partition tile:			
	3 x 12 x 30 in. solid	—	—	1.26
	3 x 12 x 30 in. 4-cell	—	—	1.35
	4 x 12 x 30 in. 3-cell	—	—	1.67
PLASTERING MATERIALS	Cement plaster, sand aggregate	116	0.20	—
	Sand aggregate	% in.	—	0.08
	Sand aggregate	% in.	—	0.15
	Gypsum plaster:			
	Lightweight aggregate	% in.	45	0.32
	Lightweight aggregate	% in.	45	0.39
	Lightweight aggregate on metal lath	% in.	—	0.47
	Perlite aggregate	45	0.67	—
	Sand aggregate	105	0.18	—
	Sand aggregate	% in.	105	0.09
	Sand aggregate	% in.	105	0.11
	Sand aggregate on metal lath	% in.	—	0.1
Vermiculite aggregate	45	0.59	—	
ROOFING	Asbestos-cement shingles	120	0.21	—
	Asphalt roll roofing	70	—	0.15
	Asphalt shingles	70	—	0.44
	Built-up roofing	% in.	70	0.33
	Slate	% in.	—	0.05
	Wood shingles, plain plastic film faced	—	0.94	—
SIDING MATERIALS (On flat surface)	Shingles:			
	Asbestos-cement	120	—	0.21
	Wood, 16", 7/8" exposure	—	—	0.87
	Wood, double, 16", 12" exposure	—	1.19	—
	Wood, plus insulating backer board	5/16 in.	—	1.40
	Siding:			
	Asbestos-cement, 1/2" lapped	—	—	0.21
	Asphalt roll siding	—	—	0.15
	Asphalt insulating siding (1/2" bd.)	—	—	1.46
	Wood drop 1 x 8"	—	—	0.79
	Wood bevel, 1/2" x 8" lapped	—	—	0.81
	Wood bevel, 1/2" x 10" lapped	—	—	1.05
	Wood plywood 1/2" lapped	—	—	0.59
	Aluminum or steel, over sheathing, hollow-backed	—	—	0.61
	Insulating-board backed nominal 1/2"	—	—	1.82
	Insulating-board backed nominal 1/2" foil backed	—	—	2.96
	Architectural glass	—	—	0.10
FINISH FLOORING MATERIALS	Carpet and fibrous pad	—	—	2.08
	Carpet and rubber pad	—	—	1.23
	Cork tile	% in.	—	0.28
	Terrazzo	1 in.	—	0.08
	Tile-asphalt, linoleum, vinyl, rubber	—	—	0.05
	Wood, hardwood finish	% in.	—	0.08
INSULATING MATERIALS Blanket and batt	Mineral fiber, fibrous form processed from rock, slag or glass			
	Approx. 2 to 2 1/2"	Note 1	—	7
	Approx. 3 to 3 1/2"	Note 1	—	11
	Approx. 5 1/2 to 6 1/2"	Note 1	—	19
Board and Slabs	Cellular glass	9	2.50	—
	Glass fiber, organic bonded	4-9	4.00	—
	Expanded rubber (rigid)	4.5	4.55	—
	Expanded polystyrene extruded, plain	1.8	4.00	—
	Expanded polystyrene extruded (R-12 exp.)	2.2	5.00	—
	Expanded polystyrene extruded (R-12 exp.) (Thickness 1" and greater)	3.5	5.26	—
	Expanded polystyrene, molded beads	1.0	3.57	—
	Expanded polyurethane (R-11 exp.)	1.5	6.25	—
	Mineral fiber with resin binder	15	3.45	—
	Mineral fiberboard wet felted			
	Core or roof insulation	16-17	2.94	—
	Acoustical tile	18	2.86	—
	Acoustical tile	21	2.70	—

Material	Description	Density (lb per cu ft)	Per inch	For thick-
			thickness R-Value	ness listed R-Value
	Mineral fiberboard wet molded			
	Acoustical tile	23	2.38	—
	Wood or cane fiberboard			
	Acoustical tile ½ in.	—	—	1.25
	Acoustical tile ¾ in.	—	—	1.89
	Interior finish (plank, tile)	15	2.86	—
	Insulating roof deck			
	Approximately 1½ in.	—	—	4.17
	Approximately 2 in.	—	—	5.56
	Approximately 3 in.	—	—	8.33
	Wood shredded (cemented in preformed slabs)	22	1.67	—
	Foil faced, glass fiber — reinforced cellular polyisocyanurate	2	7.04	—
	Nominal 0.5 in.	2	—	3.6
	Nominal 1.0 in.	2	—	7.2
	Nominal 2.0 in.	2	—	14.4
Loose Fill	Cellulose insulation (milled paper or wood pulp)	2.5-3	3.70	—
	Sawdust or shavings	0.8-1.5	2.22	—
	Wood fiber, softwoods	2.0-3.5	3.33	—
	Perlite, expanded	5.0-8.0	2.70	—
	Mineral fiber (rock, slag or glass):			
	Approximately 3" Note 1	8-15	—	9
	Approximately 4½" Note 1	8-15	—	13
	Approximately 6½" Note 1	8-15	—	19
	Approximately 7½" Note 1	8-15	—	24
	Silica aerogel	7.6	5.88	—
	Vermiculite (expanded)	7.0-8.2	2.13	—
	4.0-6.0	2.27	—
WOODS	Maples, oak and similar hardwoods	45	0.91	—
	Fir, pine, and similar softwoods	32	1.25	—
	Fir, pine, and similar softwoods ¾ in.	32	—	0.94
 1½ in.	32	—	1.89
 2½ in.	32	—	3.12
 3½ in.	32	—	4.35

Note 1: R-value varies with fiber diameter. Insulation is produced by different densities; therefore, there is a wide variation in thickness for the same R-value between various manufacturers. (See Batt and Loose Fill Insulation.)

*Reprinted with permission from ASHRAE Handbook of Fundamentals 1972.

TABLE A-5
COEFFICIENTS OF TRANSMISSION (U) OF WINDOWS, SKYLIGHTS, AND LIGHT TRANSMITTING PARTITIONS *

(These values are for heat transfer from air to air.)

Btu per (hr) (sq ft) (F Deg)

PART A

**VERTICAL PANELS (EXTERIOR WINDOWS, SLIDING PATIO DOORS
 AND PARTITIONS) — FLAT GLASS, GLASS BLOCK AND
 PLASTIC SHEET**

Description	Winter	Exterior ¹	Summer	Interior
Flat Glass				
single glass	1.13		1.06	0.73
insulating glass — double²				
3/16 in. air space	0.69		0.64	0.51
1/4 in. air space	0.65		0.61	0.49
1/2 in. air space	0.58		0.56	0.46
1/2 in. air space, low emissivity coating ³				
emissivity = 0.20	0.38		0.36	0.32
emissivity = 0.40	0.45		0.44	0.38
emissivity = 0.60	0.52		0.50	0.42
insulating glass — triple²				
1/4 in. air spaces	0.47		0.45	0.38
1/2 in. air spaces	0.36		0.35	0.30
storm windows				
1 in.-4 in. air space	0.56		0.54	0.44
Glass Block⁴				
6 x 6 x 4 in. thick	0.60		0.57	0.46
8 x 8 x 4 in. thick	0.56		0.54	0.44
— with cavity divider	0.48		0.46	0.38
12 x 12 x 4 in. thick	0.52		0.50	0.41
— with cavity divider	0.44		0.42	0.36
12 x 12 x 2 in. thick	0.60		0.57	0.46
Single Plastic Sheet	1.09		1.00	0.70

¹See Part C for adjustment for various window and sliding patio door types.

²Double and triple refer to the number of lights of glass.

³Coating on either glass surface facing air space; all other glass surfaces uncoated.

⁴Dimensions are nominal.

*Reprinted with permission from ASHRAE Handbook of Fundamentals.

PART B
HORIZONTAL PANELS (SKYLIGHTS)
FLAT GLASS, GLASS BLOCK AND PLASTIC BUBBLES

Description	Winter ⁵	Exterior ¹	Summer ⁶	Interior ⁵
Flat Glass				
single glass	1.22		0.83	0.96
insulating glass — double²				
3/16 in. air space	0.75		0.49	0.62
1/4 in. air space	0.70		0.46	0.59
1/2 in. air space	0.66		0.44	0.56
1/2 in. air space, low emissivity coating ³				
emissivity = 0.20	0.46		0.31	0.39
emissivity = 0.40	0.53		0.36	0.45
emissivity = 0.60	0.60		0.40	0.50
Glass Block⁴				
11 x 11 x 3 in. thick with cavity divider	0.53		0.35	0.44
12 x 12 x 4 in. thick with cavity divider	0.51		0.34	0.42
Plastic Bubbles⁷				
single walled	1.15		0.80	—
double walled	0.70		0.46	—

⁵For heat flow up.

⁶For heat flow down.

⁷Based on area of opening, not total surface area.

(See following page for Part C of this table.)

PART C
ADJUSTMENT FACTORS FOR VARIOUS WINDOW AND SLIDING PATIO DOOR TYPES
(Multiply U values in Parts A and B by these factors)

Description	Single Glass	Double or Triple Glass	Storm Windows
Windows			
All Glass ⁸	1.00	1.00	1.00
Wood Sash — 80% Glass	0.90	0.95	0.90
Wood Sash — 60% Glass	0.80	0.85	0.80
Metal Sash — 80% Glass	1.00	1.20	1.20 ⁹
Sliding Patio Doors			
Wood Frame	0.95	1.00	—
Metal Frame	1.00	1.10	—

⁸Refers to windows with negligible opaque area.

⁹Value becomes 1.00 when storm sash is separated from prime window by a thermal break.

TABLE A-6
COEFFICIENTS OF TRANSMISSION (U) FOR SLAB DOORS*
Btu per (hr) (sq ft) (F Deg)

Thickness ¹	Winter			Summer, No Storm Door
	Solid Wood, No Storm Door	With Storm Door		
		Wood	Metal	
1 in.	0.64	0.30	0.39	0.61
1½ in.	0.55	0.28	0.34	0.53
1¾ in.	0.49	0.27	0.33	0.47
2 in.	0.43	0.24	0.29	0.42
	Steel Door			
1½ in. A ³	0.59	—	—	0.58
B ⁴	0.19	—	—	0.18
C ⁵	0.47	—	—	0.46

¹Nominal thickness.

²Values for wood storm doors are for approximately 50% glass; for metal storm doors values apply for any percent of glass.

³A = Mineral fiber core (2 lb/cu ft).

⁴B = Solid urethane foam core with thermal break.

⁵C = Solid polystyrene core with thermal break.

Note: Hollow core doors 1½ in. thick - R = 2.17; U = 0.46
1¾ in. thick - R = 2.22; U = 0.45

*Reprinted with permission from ASHRAE Handbook of Fundamentals.

INSULATION, EQUIPMENT AND CONDENSATION CONTROL

This appendix is a guide for the proper installation of insulation. The preceding appendices indicated the required amounts and types of insulation necessary to provide the various thermal resistance values for the building envelope. In order to attain the resistance values specified, it is important that the insulation be properly installed. This appendix includes types of materials currently available and common application practices.

Condensation control should be provided in the form of vapor barriers and thermal breaks. Vapor barriers should be installed on the warm side (area heated in winter) of all walls, ceilings, and insulated floors. All metal window, skylight, and door frames should contain a thermal break.

Insulation is manufactured in many forms and types. The most commonly used materials in residential construction are batts and blankets, rigid insulation, reflective insulation, loose fill, and sprayed insulation. The following is a list of types of materials and the federal specifications governing their characteristics.

Cork board	FS HH-I-561
Cellular glass	FS HH-I-551
Duct insulation	FS HH-I-558b
Expanded polystyrene insulation board	FS HH-I-524
Fiberboard	FS LLL-I-535 or ASTM C-208 Class C
Insulation board (urethane)*	FS HH-I-530
Insulation, thermal (perlite)	FS HH-I-574
Mineral fiber, pneumatic or poured	FS HH-I-1030A
Mineral fiber, insulation blanket	FS HH-I-521E
Perlite	FS HH-I-526a
Perimeter insulation	FS HH-I-524a Type II
.....	FS HH-I-558b Form A, Class 1 or 2
Reflective, thermal	FS HH-I-1552
Structural fiberboard insulation roof deck	AIMA IB Spec. No. 1
Cellulose; vegetable or wood fiber	FS HH-I-515b-25
Vermiculite	FS HH-I-585
Vermiculite, water repellent loose fill	FHA UM-30
Mineral fiber, roof insulation	HH-I-526c

BATTS AND BLANKETS

These materials are usually identified on the package and on the vapor barrier facing with their "R" values. Under the federal specifications, there are 3 standard products identified as R-7, R-11, and R-19. These values are based on the insulation value of the mass. Some manufacturers offer other products such as R-8, R-13 and R-22. The specific thickness of insulation required for a specific "R" value may vary from one manufacturer to another due to differences in base materials and manufacturing processes.

General Guidelines

1. Install insulation so the vapor barrier faces the interior of the dwelling.
2. Vapor barriers should not be left exposed.
3. Insulate all voids of the building envelope including small spaces, gaps, around receptacles, pipes, etc.
4. Place insulation on the cold side of pipes and ducts (see Fig. 4). Insulation is not required for supply and return air ducts in heated basements and cellars.

Ceilings

There is a variety of methods for installing blanket insulation in ceilings.

1. Fastening from below (Fig. 1b).
2. Installing unfaced (without a vapor barrier), friction-fit blankets (Fig. 2).
3. Laying the insulation in from above when the ceiling finish material is in place (Fig. 1a).

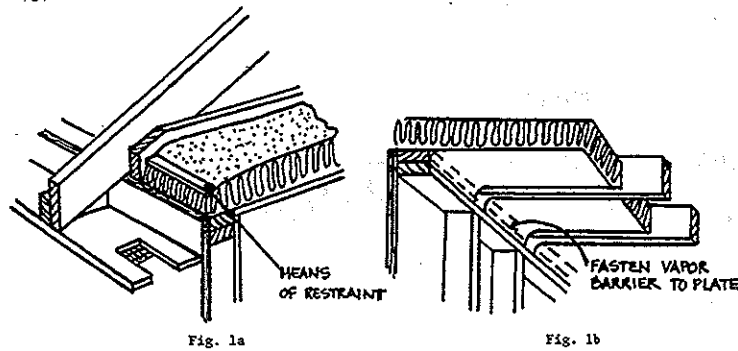

Fasten flanges to the inside of ceiling joists as shown in Fig. 1b. Extend the insulation entirely across the top plate, keeping the blanket as close to the plate as possible. Fasten vapor barrier to plate. When eave vents are used, the insulation should not block air movement from eave to space above insulation (Fig. 1a).

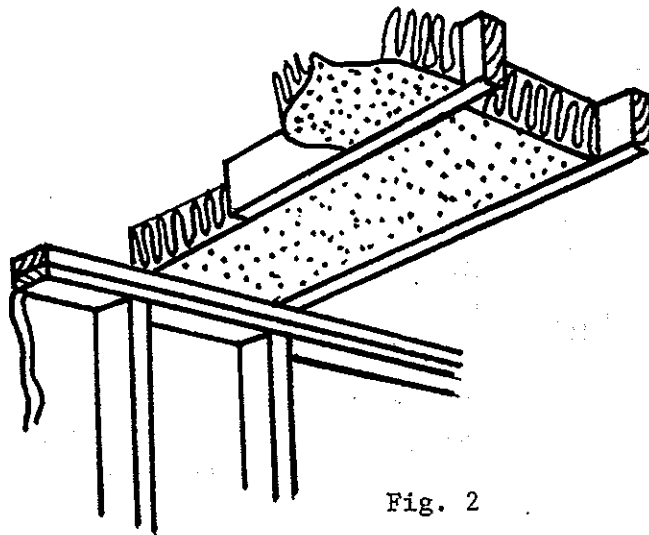

Insert friction-fit blankets between ceiling joists (Fig. 2). Allow insulation to overlap the top plate of the exterior wall, but not enough to block eave ventilation. The insulation should be in contact with the top of the plate to avoid heat loss and air infiltration beneath the insulation. The required vapor barrier is not shown.

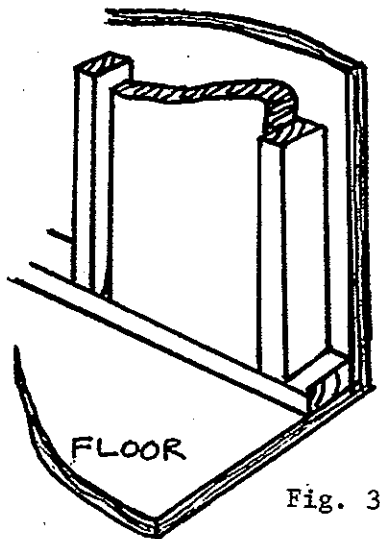

ILHR 20-25 Appendix

Insert blankets into stud spaces. Working from the top down, space fasteners per manufacturers recommendations, fitting flanges tightly against face of stud (Fig. 3). Cut blankets slightly over length and fasten the vapor barrier to the top and bottom plates.

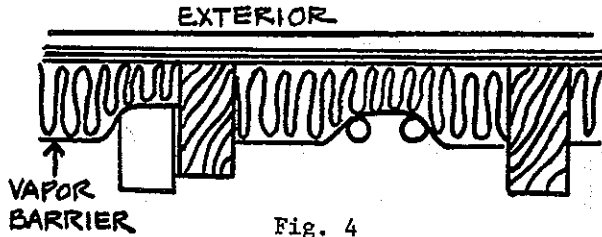

Fig. 4

Insert insulation behind (cold side in winter) pipes, ducts, and electrical boxes (Fig. 4).

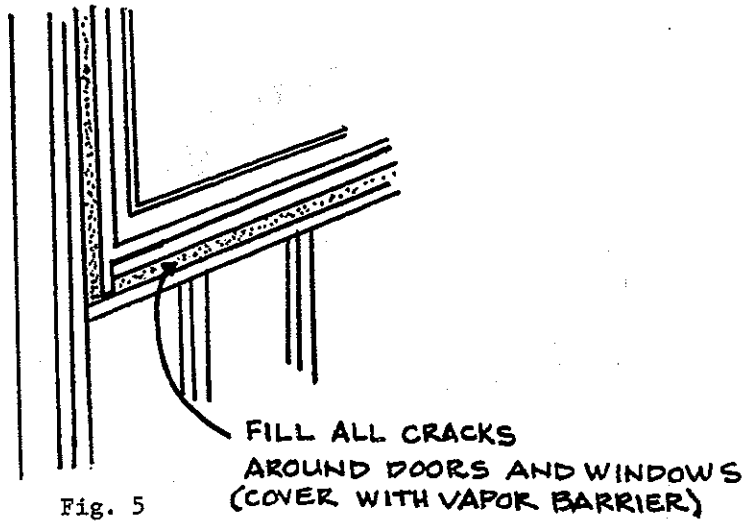

Fig. 5

Fill small spaces between rough framing and door and window heads, jambs and sills with pieces of insulation (Fig. 5).

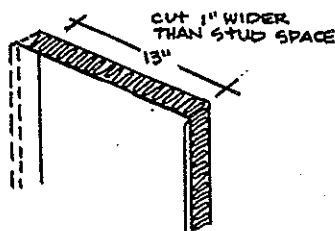

Fig. 6a

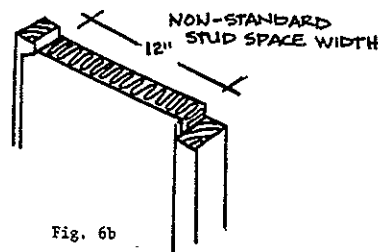
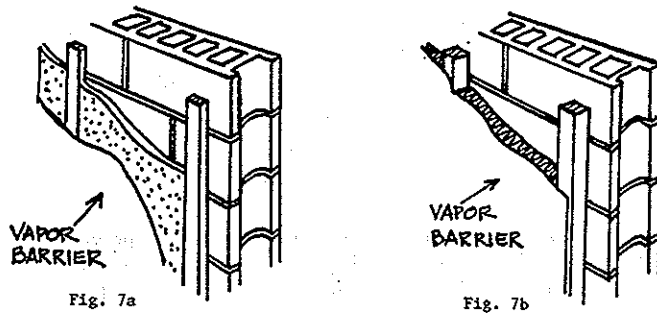

Fig. 6b

Insulate nonstandard-width stud or joist spaces by cutting the insulation and vapor barrier an inch or so wider than the space to be filled (Fig. 6a). Pull the vapor barrier on the cut side to the other stud, compressing the insulation behind it, and fasten through vapor barrier to stud face (Fig. 6b). Unfaced blankets are cut slightly oversize and fitted into place.



Masonry walls may be insulated by inserting insulation between furring strips spaced at 16 or 24 inches o.c. (Fig. 7a and 7b). It is recommended to apply the vapor barrier to the inside surface.

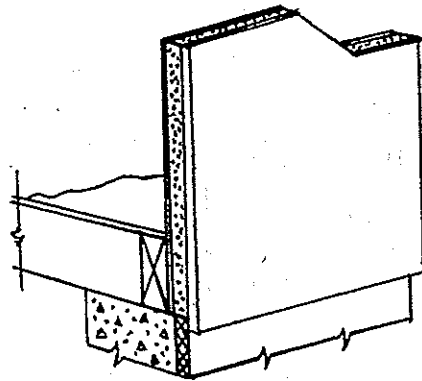
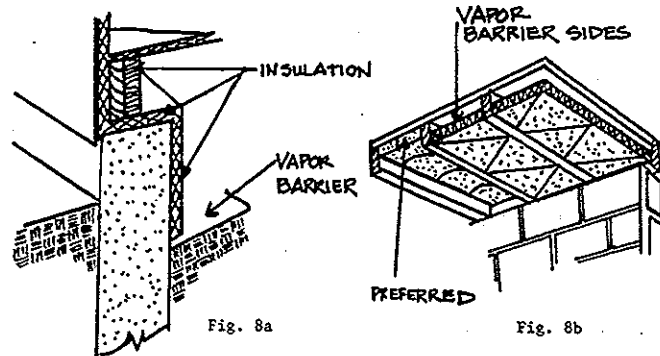

Fig. 8

Rigid insulation in stress skin panels (Fig. 8) may also be used to insulate walls, ceilings and roofs.

Floor and Crawl Spaces



Floors over crawl spaces (Fig. 8a) should be insulated either by insulating the foundation walls or by placing insulation on or between the joists. Insulation should be securely fastened. In all cases, the vapor barrier side of the

insulation should face the floor above; that is, be adjacent to the warm side in winter. A vapor barrier should be used to cover the ground.

Dropped Soffits

Insulation of dropped soffits over kitchen cabinets, bathtubs, showers, or similar areas, need special attention when they are exposed to the attic. If the dropped soffit is framed before ceiling finish material is applied, a "board" (plywood, hardboard, gypsumboard, etc.) should be installed over the cavity to support insulation.

In multiple dwellings with back-to-back kitchens or baths, it is necessary to extend ceiling finish material over dropped soffits to the party wall to avoid loss of acoustical control and to provide adequate fire stops.

Rigid Insulation

Rigid insulation is available in various sizes and thicknesses made of polystyrene, polyurethane, cork, cellular glass, mineral fiber (glass or rock wool), perlite, wood fiberboard, etc. They are used as insulation for masonry construction, as perimeter insulations around concrete slabs, as exterior sheathing under the weather barrier, as rigid insulations on top of roof decks, and other applications.

Installation Procedures

Masonry walls: Rigid insulations are applied to either face of a masonry wall (Fig. 9a and 9c) or are used as a cavity insulation between two wythes of masonry (Fig. 9b). When applied to the face of masonry walls, they are generally installed with adhesive and/or mechanical fasteners. The manufacturer's recommendation should be followed.

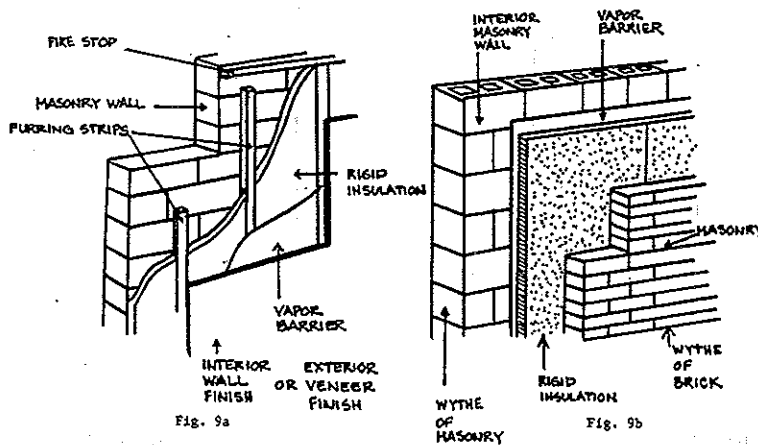

Fig. 9c

Frame Construction: When rigid insulation is used with frame construction (Fig. 10), it is usually applied as sheathing to the outside of the framing, and mechanically attached with nails to wood studs or to metal studs with screws or clips or other approved methods.

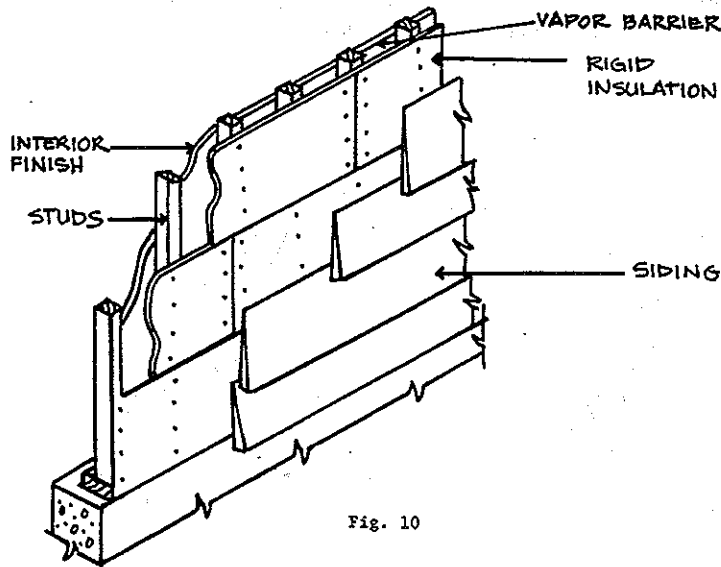

Fig. 10

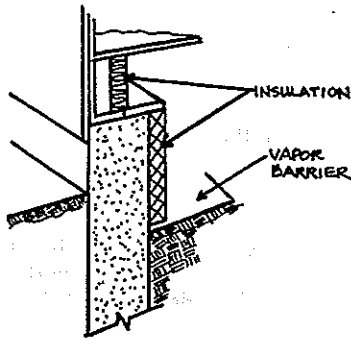

Fig. 11a

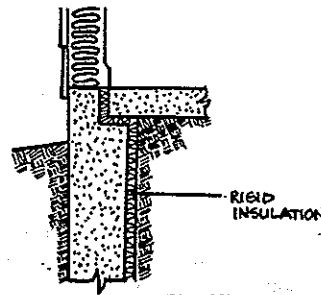

Fig. 11b

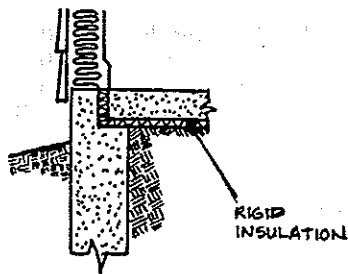

Fig. 11c

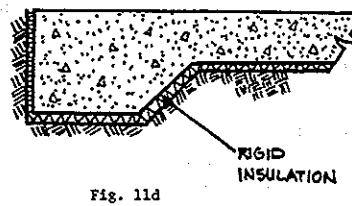

Fig. 11d

Roof Insulation: Roof insulation boards are usually installed with an approved adhesive, hot asphalt, or may be nailed to the roof sheathing. The manufacturer's instructions should be followed.

Slab-on-Grade: Rigid insulation is frequently used as insulation around the perimeter of concrete slabs-on-grade (Fig. 11b, c, d) and also may be used on the inside of foundation walls adjacent to heated crawl spaces, basements or cellars (Fig. 11a). Installation is usually accomplished with adhesive and/or mechanical fasteners. Perimeter insulation should be installed against the foundation wall or extended into the interior of the building to a distance equal to the design frost line (Fig. 11b, c and d). Where the slab bears on the foundation ledge, the insulation should be a load-bearing type.

WISCONSIN ADMINISTRATIVE CODE

INSULATED CONCRETE BLOCK

Concrete block manufacturers are currently producing several types of multi-celled block with improved insulating values. The thermal resistance of the block will vary depending upon the types of insulation used and the configuration of the cells. An example of a typical multi-celled block is shown below.

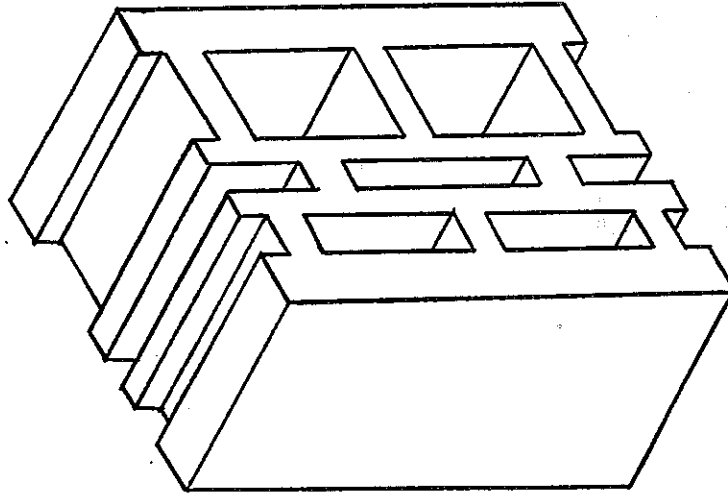

LOOSE FILL INSULATION

Materials of this type are those made from mineral fibers (rock or glass), cellulose materials (wood fibers or shredded paper), or other manufactured products that can easily be poured.

BLOWN ATTIC INSULATION

There are several factors pertaining to blown attic insulation that can cause differences in its installed thermal resistance value (R). For a given manufacturer's insulation, the installed thermal resistance (R) value depends on thickness and weight of insulating material applied per square foot. Federal specification HH-I-1030A for insulation requires that each bag of insulation be labeled to show the minimum thickness, the maximum net coverage, and the minimum weight of (that particular) insulation material required per square foot to produce resistance values of R-30, 22, 19, and 11. A bag label example for blown insulation is shown in Fig. 12.

The number of bags of blown insulation required to provide a given R-value to insulate an attic of a given size may be calculated from data provided by the manufacturer. If only the thickness of blown attic insulation is specified, and the density or number of bags is not, the desired or assumed thermal resistance (R) value may not be achieved. The important characteristic is weight per square foot. Thickness is the minimum thickness, not the average thickness experienced in the field.

Adequate baffling of the vent opening or insulation blocking should be provided so as to deflect the incoming air above the surface of the installed blown or poured insulation. Baffles should be made of durable material securely fastened. Baffles should be in place at the time of framing inspection.

Three blown insulations that provide R-19 are:

<u>Material</u>	<u>Minimum Thickness</u>	<u>Maximum Net Coverage/Bag</u>	<u>Bags/1000 Sq. Ft.</u>
Cellulose	5"	59 sq. ft. (40 lb. bag)	17
Glass fiber	8"	51 sq. ft. (24 lb. bag)	20
Rock wool	6 1/2"	26 sq. ft. (27 lb. bag)	38

Bag Label Example: The manufacturer recommends these maximum coverages at these minimum thicknesses to provide the levels of installed insulation resistance (R) values shown:

(Based on 25-pound nominal weight bag)

R-Value	Minimum Thickness	Minimum Weight per Sq. Ft.	Bags per 1000 Sq. Ft.	Maximum Net Coverage per Bag
To obtain an insulation resistance R of:	Installed insulation should not be less than:	The weight per sq. ft. of installed insulation should be not less than:	Number of bags per 1000 sq. ft. of net area should not be less than:	Contents of this bag should not cover more than:
R-30	13½ in. thick	0.768 lbs. per sq. ft.	30	33 sq. ft.
R-22	10 in. thick	0.558 lbs. per sq. ft.	22	45 sq. ft.
R-19	8½ in. thick	0.489 lbs. per sq. ft.	20	51 sq. ft.
R-11	5 in. thick	0.279 lbs. per sq. ft.	11	90 sq. ft.

Weight contents: not less than 24 lbs.

R-values are determined in accordance with ASTM C-687 and C-236

Fig. 12

REFLECTIVE INSULATION

Reflective insulation is composed of aluminum foil in one or more layers either plain or laminated to one or both sides of kraft paper for structural strength. The insulation value for reflective air spaces, which this type of insulation provides, varies widely depending on the direction of heat flow. They are much more efficient when the heat flow is *down*. Reflective insulations which comply with the requirements when used in a floor, may not be satisfactory in ceilings or walls, where the heat flow is upward and horizontal, respectively. Reflective insulations are effective in controlling radiant heat energy when installed so that they face an air space. Insulation should be installed in such a manner that it is continuous, without holes or tears.

SPRAYED INSULATION

There are several types of insulation which are sprayed against the surface of the building materials or in cavities. Some of these are cellulose with binder, mineral wool with binder, and cellular foams. They may be sprayed directly on concrete, masonry, wood, plastic, or metal panels or may be sprayed between the framing members. Manufacturer's recommended instructions should be followed. To determine that the proper thickness is installed, either refer to the plans and specifications, or request a certification from the supplier that the insulation installed provides the required "R" value.

TYPICAL INSULATION THICKNESSES AND VALUES

Insulation	Approximate R-Value	Thickness
Fiber glass	11	3½"
Fiber glass	13	3"
Fiber glass	19	6"
Fiber glass	30	8"
Fiber glass	38	12"
Extruded Polystyrene Foam	5.4	1"
Extruded Polystyrene Foam	10.8	2"

VAPOR RETARDERS

Vapor retarders are used in conjunction with insulation to decrease the change of moisture condensation inside the building insulation. Vapor retarders are placed on the side of the wall, ceiling or floor that is warm in winter. For equal vapor pressures, moisture vapor penetration through holes or tears in the insulation vapor retarder is proportional to the size of the opening. Holes or tears should be repaired. A snug fit of blanket flanges against the framing is necessary to prevent moisture from bypassing the vapor retarder.

EQUIPMENT

The installation of the heating system can contribute to inefficiencies. A furnace which is oversized by a factor of 2 will require 8 to 10% more fuel than a furnace of correct size. An installation that has uninsulated ducts passing through an unheated crawl or attic space will lose about 1.5 Btu per hour per square foot of duct per degree of temperature differential between duct air and outside air. This can amount to 40% of a furnace output under mild conditions. Undersized ducting will reduce the amount of circulating air and will affect the capacity of the furnace, but will normally have little effect upon its efficiency. Atmospheric combustion equipment that draws its combustion and stack-dilution air from the heated space will require more fuel to heat the required makeup air than sealed combustion equipment. Stack heat recovery devices can recover from about 4% at 450° F to 8% at 800° F.

The appliance manufacturer should be consulted when retrofitting the appliance with combustion air to assure that the appliance warranty is not affected.

Effect of Sizing Limitation on Equipment

Using the example on system design illustrated in Appendix A, an analysis was made to see what impact or problem the proposal for limiting the size of equipment to 15% above the design losses would have.

Example:

Total construction loss 27,760 Btu/hour

One air change per hour:

Inside volume = 12,188 cu. ft.

$Q = (12,188) (90) (.018) = 19,744$ Btu/hour

Total infiltration loss 19,744 Btu/hour
47,504 Btu/hour

Maximum furnace size:

$47,504 \text{ Btu/hour} + 47,504 (.15) \text{ Btu/hour} = 54,630 \text{ Btu/hour}$

COMBUSTION AIR FOR FIREPLACES

It is recommended that combustion air from the exterior be provided for all fireplaces. Masonry fireplaces can be made more energy efficient with combustion air terminating in the fireplace. The opening of the fireplace should be equipped with a door and the combustion air duct with a damper and a louver to minimize air leakage during periods of nonuse.

CONDENSATION CONTROL*Air Infiltration*

The department will accept infiltration losses determined by the air crack method or an overall value of ½ air change per hour.

The department will accept the use of engineered top-side moisture vent systems.

Relative Humidity

Winter: During the winter it is desirable to have humidity in the air in order to prevent the nostrils from becoming dry, furniture from cracking, etc. However, from an energy standpoint, it is desirable to keep the relative humidity low; the trade-off is at about 30%.

Summer: During the summer it is desirable to reduce the level of relative humidity in the building in relationship to the outside relative humidity. The relative humidity should be kept as high as possible in order to conserve energy, but low enough for comfort. The relative humidity should be kept above 55%, but less than 60%.

ILLUSTRATIONS OF EXTERIOR OPENINGS IN THE THERMAL ENVELOPE

The following illustrations show some exterior openings in the thermal envelope which may be sealed to control infiltration. A detailed list of sealing requirements for electrically heated homes is given in s. ILHR 22.13 (3).

ILHR 22.13 Infiltration Control for Electrically Heated Homes

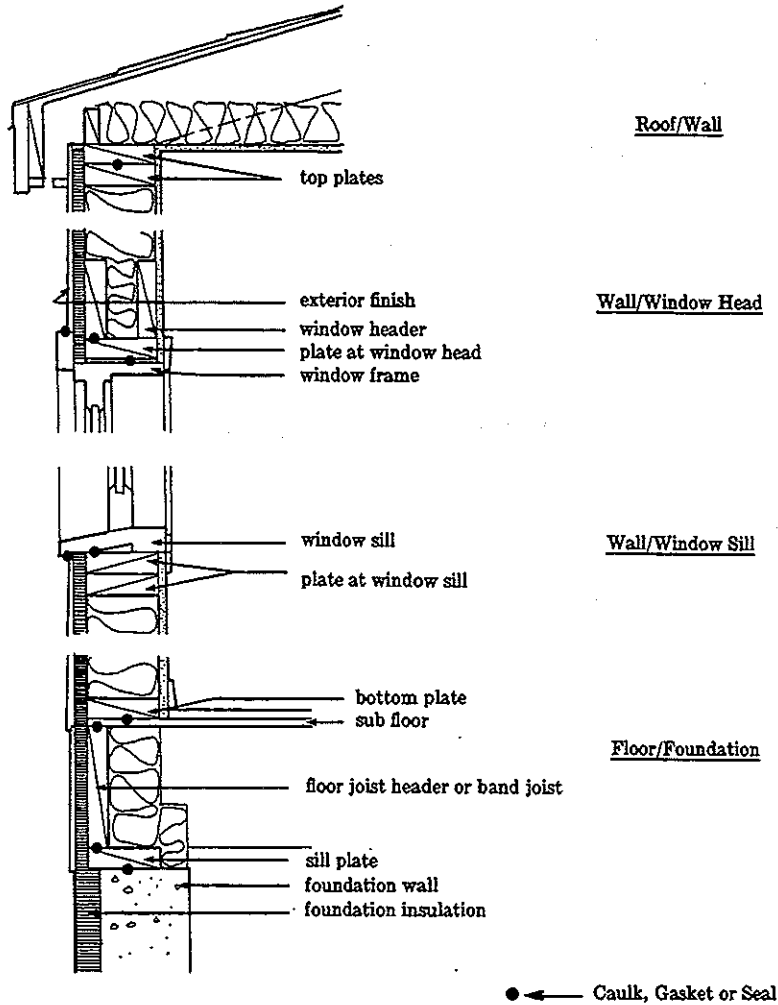

ILHR 22.13 Infiltration Control for Electrically Heated Homes (continued)

