



CR 90-230

State of Wisconsin

DEPARTMENT OF NATURAL RESOURCES

Carroll D. Besadny, Secretary  
Box 7921  
Madison, Wisconsin 53707  
TELEFAX NO. 608-267-3579  
TDD NO. 608-267-6897

STATE OF WISCONSIN )  
 )  
DEPARTMENT OF NATURAL RESOURCES ) ss

TO ALL TO WHOM THESE PRESENTS SHALL COME, GREETINGS:

I, Bruce B. Braun, Deputy Secretary of the Department of Natural Resources and custodian of the official records of said Department, do hereby certify that the annexed copy of Natural Resources Board Order No. WR-78-90 was duly approved and adopted by this Department on February 28, 1991. I further certify that said copy has been compared by me with the original on file in this Department and that the same is a true copy thereof, and of the whole of such original.

IN TESTIMONY WHEREOF, I have hereunto set my hand and affixed the official seal of the Department at the Natural Resources Building in the City of Madison, this 30th day of April, 1991.

RECEIVED

7 1991  
10:50 am  
Revisor of Statutes  
Bureau

Bruce B. Braun  
Bruce B. Braun, Deputy Secretary

(SEAL)

7-1-91



ORDER OF THE STATE OF WISCONSIN NATURAL RESOURCES BOARD  
REPEALING, RENUMBERING, AMENDING, REPEALING AND RECREATING,  
AND CREATING RULES

.....  
IN THE MATTER of repealing s. NR 141.13(2)(a)5 and  
6; renumbering s. NR 141.23(1)(i), amending .  
ss. NR 141.03, 141.05(7), (8) & (18), 141.065(2), .  
141.07(1), 141.09(1), 141.10(2)(d) & (f), .  
141.11(1) to (3), 141.13(1) and (2)(a)(intro.), 1,  
2 & 3, and (b)(1) and 4 & (3), 141.21(intro.), .  
(1)(a) and (b) & (2), 141.23(1)(h) and .  
141.25(2)(b), (d)(1) to (3), and (3); repealing .  
and recreating ss. NR 141.09(2)Figure 1, .  
141.10(2)(f)Figure 3, 141.13(2)(a)4; and creating .  
ss. NR 141.05(2m), (21m) & (33m), .  
141.05(46)(note), 141.13(4), 141.13(4)(b)Figure 4, . WR-78-90  
141.16, 141.19(1)(c)(note), 141.20 and .  
141.23(1)(i) of the Wisconsin Administrative Code .  
pertaining to the regulation of the construction .  
and installation of groundwater monitoring wells .  
.....

RECEIVED

7 1991

Revisor of Statutes  
Bureau .

Analysis Prepared by Department of Natural Resources

Statutory authority: ss. 144.025(2)(c), 144.431(1)(a),  
144.435(1), 144.441(1m), 144.442(5)(b) to (d), 144.62(9)(d),  
144.76(5)(a), 144.83(1)(a), (2)(a) and (b)11. and 12. and (4)(i),  
147.08(1)(c) and (d), and 227.11(2)(a), Stats.

Statutes interpreted: ss. 144.025(2)(c), 144.431(1)(a),  
144.435(1), 144.441(1m), 144.442(5)(b) to (d), 144.62(8)(d),  
144.76(5)(a), 144.83(1)(a), (2)(a) and (b)11. and 12. and (4)(i),  
147.08(1)(c) and (d), 160.19(1) and (2)(a), and 160.27, Stats.

The Department's environmental protection programs have recognized the need for uniform regulations regarding the installation and construction of groundwater monitoring wells. The technique used to install a well to a large extent determines the accuracy of the water quality samples taken from the well. An improperly constructed well may not produce samples that accurately reflect existing groundwater quality, resulting in improper agency actions. Since the state relies on numerical water quality standards to protect the resource, it is essential that monitoring wells are installed properly. The amendments to chapter NR 141, as proposed, clarify or improve upon the minimum standards of monitoring well construction, development, installation and abandonment which exist in the present rule. Specific new requirements are established for: 1) flush mounted protective cover pipes, 2) chip bentonite or high-solids grout as an annular space seal, 3) aquifer test wells, 4) recovery wells, and 5) construction of groundwater monitoring wells in shallow water table areas.

SECTION 1. NR 141.03 is amended to read:

**NR 141.03 APPLICABILITY.** This chapter applies to all persons installing and abandoning groundwater monitoring wells and boreholes for purposes regulated by the department under ch. 144, 147 or 160, Stats., or in permits, plan approvals, licenses or orders issued under those chapters. In addition, this chapter applies to all persons installing groundwater monitoring wells and boreholes in fulfillment of terms of a contract with the department. All wells and boreholes installed for purposes regulated by the department under this chapter shall be abandoned according to s. NR 141.25. All other wells and boreholes shall be abandoned according to the provisions of ch. NR 112.

Note: Additional requirements concerning soil testing and groundwater sampling are located in other chapters regulating wastewater and solid and hazardous waste disposal, see chs. NR 110, ~~181~~, 206, 213, 214, 508, 512 and 550 and the 600 series.

SECTION 2. NR 141.05(2m) is created to read:

NR 141.05(2m) "Aquifer test well" means a well installed to provide information on the hydraulic conductivity, transmissivity, storage coefficient, capture zone, specific capacity, radius of influence or other physical parameters of an aquifer, defined geologic unit, or water bearing formation through the imposition of a sustained stress on the aquifer by removal of water.

SECTION 3. NR 141.05(7), (8) and (18) are amended to read:

NR 141.05(7) "Bentonite - cement grout" means a mixture with a ratio of 5 pounds of bentonite with 94 pounds of Portland cement and ~~5 to 6~~ 8.5 gallons of water from a known safe and uncontaminated source.

(8) "Bentonite - fine sand slurry" means a mixture with the minimum ratio of ~~55~~ 50 pounds of bentonite with 100 gallons of water from a known safe and uncontaminated source and 10-25% sand by volume for a mud weight of ~~12~~ 11 pounds per gallon.

(18) "Granular bentonite slurry" means a thoroughly blended mixture of up to 30 pounds of untreated bentonite powder added to 100 gallons of water from a known safe and uncontaminated source with ~~125~~ a minimum of 100 pounds of untreated bentonite granules mixed together ~~with~~ by a Venturi-hopper mud mixer or other equivalent high shear mixer.

SECTION 4. NR 141.05(21m) and (33m) are created to read:

NR 141.05(21m) "High-solids grout" means a thoroughly blended mixture of water from a known safe and uncontaminated

source with untreated bentonite, without additives, which has been approved by the department.

(33m) "Recovery well" means a well intended and designed to capture and remove contaminated groundwater or non-aqueous phase liquids from the subsurface.

SECTION 5. NR 141.05(46) (note) is created to read:

Note: Construction of a typical water table observation well is depicted in Figure 1.

SECTION 6. NR 141.065(2) is amended to read:

NR 141.065(2) Following installation of the wells, an as-built plan map shall be submitted specifying the exact vertical and horizontal location of the wells. All monitoring well locations shall be reported to the department on a plan map drawn to a specific scale. The map shall indicate structure boundaries, property boundaries, any nearby surface waters and a north arrow. The plan shall show the wells in relation to each other, to property and structure boundaries, and to a common reference point on a horizontal grid system. The origin of the grid system shall be located according to latitude ~~or~~ and longitude or according to the state plane coordinate system. The exact vertical location of the top of the well casing shall be referenced to the nearest benchmark for the national geodetic survey datum to an accuracy of 0.01 feet. This plan map shall show the exact location of the installed well on a horizontal grid system which is accurate to within one foot. Direction of groundwater flow shall be indicated. In addition, an 8.5-inch by 11-inch site map drawn to scale according to the horizontal grid system shall be submitted showing the location of wells and structures on the site.

SECTION 7. NR 141.07(1) is amended to read:

NR 141.07(1) SPECIFICATIONS. All permanent groundwater monitoring wells shall be constructed of new polyvinyl chloride (PVC) well casing materials except in situations where the rock, soil or groundwater may react with PVC, in which case an approval under s. NR 141.31 for alternative materials shall be requested. All PVC casing materials shall meet national sanitation foundation standard 14 and ASTM D1785 specifications for any one of the following cell classifications: 12454-B, 12454-C, 11443-B, 14333-D, 13233 or 15223-B. All casing shall have a minimum inside diameter of 1.9 inches. In unconsolidated geologic formations, all wells less than or equal to 100 feet in depth shall be constructed of at least schedule 40 PVC casing and all wells greater than 100 feet in depth shall be constructed of at least schedule 80 PVC casing. ~~All groundwater monitoring wells that penetrate greater than 2 feet past the top of the~~

~~bedrock shall be constructed of at least schedule 80 PVC.~~  
Groundwater monitoring wells shall be installed with well casing no larger than a 4-inch inside diameter. Groundwater monitoring wells shall have a vented cap except as provided in s. 141.13(4)(b).

SECTION 8. NR 141.09(1) is amended to read:

NR 141.09(1) SPECIFICATIONS. All permanent groundwater monitoring well screens shall be constructed of material which is nonreactive with the constituents in soils and groundwater at the monitoring location. The well screen may not be hand cut and may not be wrapped with filter cloth. The well screen slot size shall be sized to retain at least ~~50~~90% of the grain size of the collapsed formation, based on a ~~field~~ sieve analysis, when collapsed formation is used as filter pack material or at least 90% of the grain size of the filter pack, based on a sieve analysis, if material other than collapsed formation is used. Well screens on water table observation wells may not exceed 15 feet in length. Well screens on piezometers installed for the purpose of determining the elevation of the potentiometric surface may not exceed 5 feet in length.

Note: Well screens for wells other than the water table observation wells and piezometers identified above may vary in length.

SECTION 9.  
read:

NR 141.09(2) Figure 1 is repealed and recreated to

**Figure 1.**  
Typical water table observation well and  
piezometer construction details.

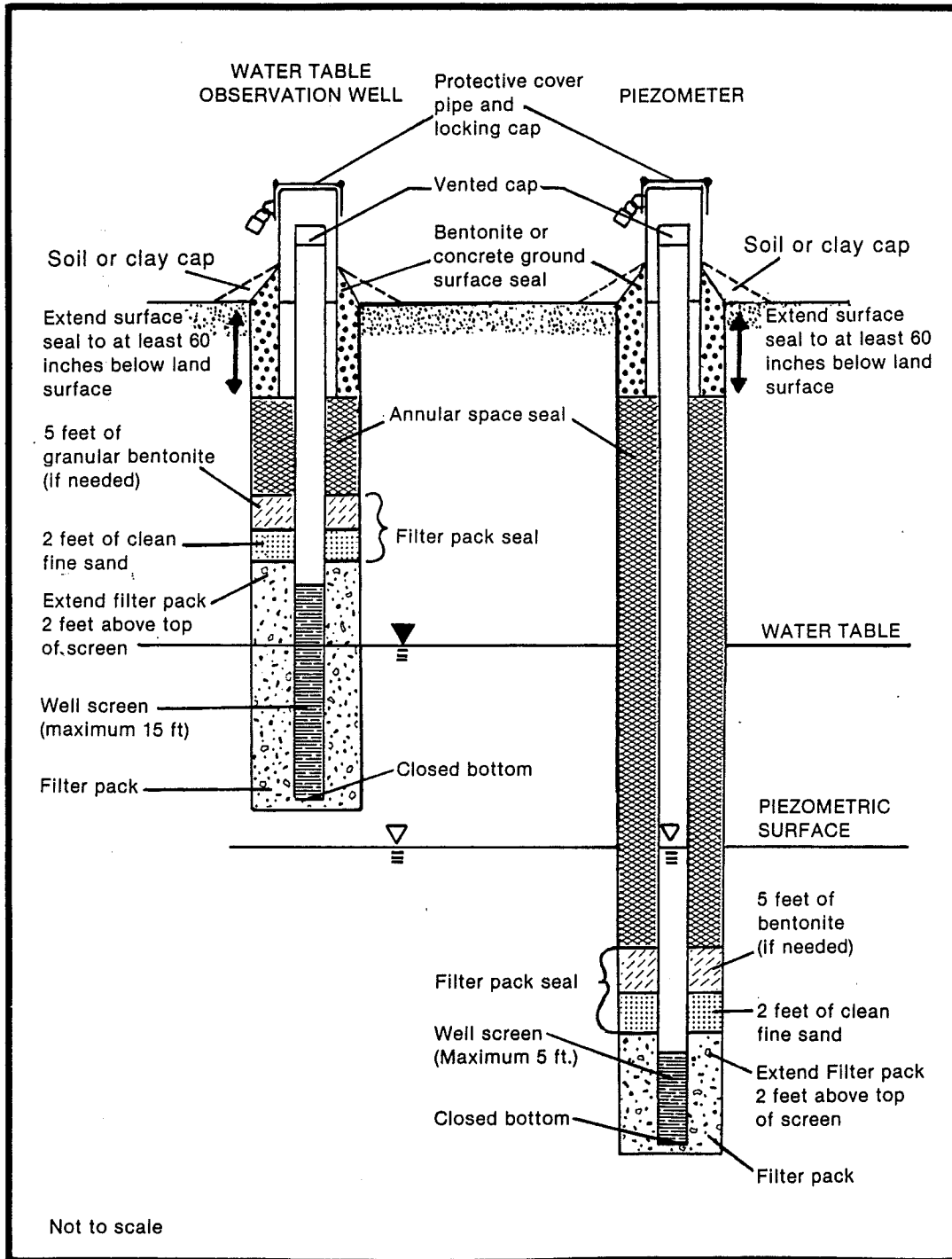

SECTION 10. NR 141.10(2)(d) and (f) are amended to read:

NR 141.10(2)(d) The sealant material shall be brought up to the ground surface seal. The density of the sealant material ~~flowing from~~ in the annular space or borehole at the bottom of the ground surface seal shall be the same as the density of the sealant material being placed. Any settling of the sealant material shall be topped off.

(f) Tremie pipe - pumped. As depicted in Figure 3, the sealing material shall be placed by a pump through a tremie pipe into the annular space or borehole. Tremie pipes used for the placing of pumped slurry or grout shall be fitted with a J-hook end or a closed end with side discharge ports.

Note: The J-hook end or closed end with side discharge ports of the tremie pipe will direct the flow of the materials to the side or upward.



SECTION 11.  
to read:

NR 141.10(2)(f) Figure 3 is repealed and recreated

**Figure 3.**  
Tremie pipe-pumped method.

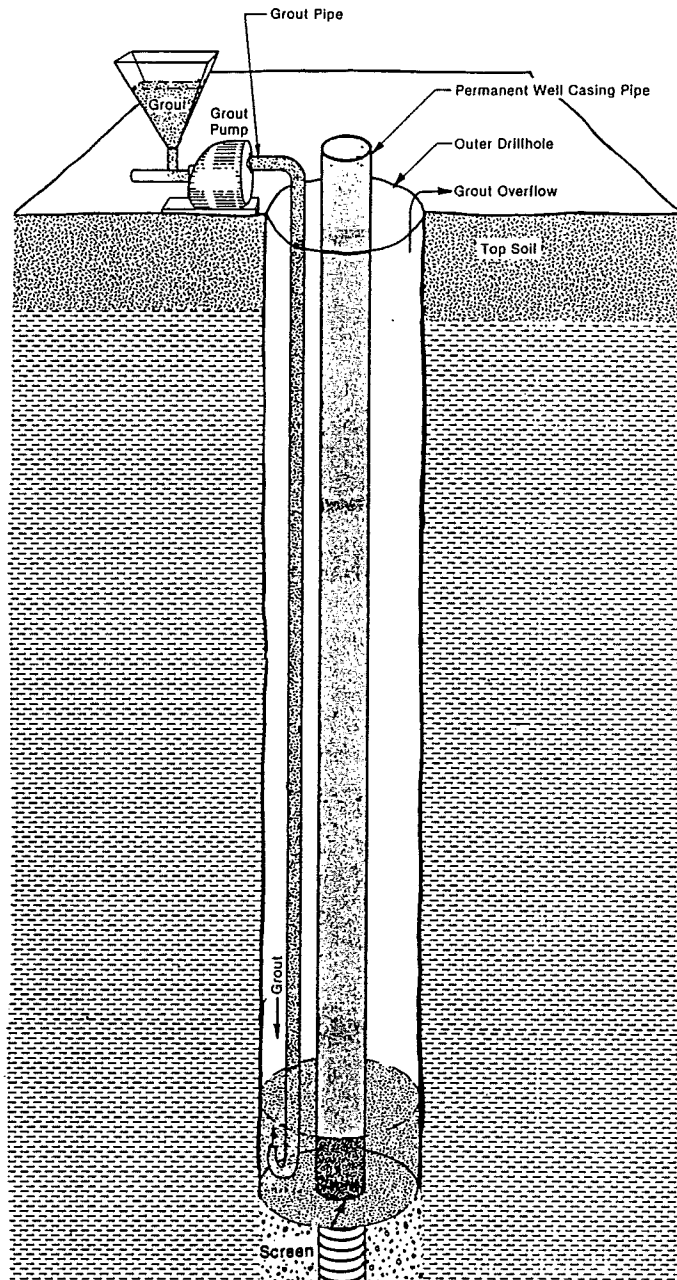

SECTION 12. NR 141.11(1) to (3) are amended to read:

NR 141.11(1) SPECIFICATIONS. The filter pack shall be a well sorted, silica based sand or gravel. The sand or gravel used for filter packs shall be hard and durable and shall have an average specific gravity of not less than 2.50. The sand and gravel shall be visibly free of clay, dust and micaceous and organic matter. Not more than 5% of the sand or gravel shall be soluble in a 10% hydrochloric acid solution. Thin, flat or elongated pieces of gravel, the maximum dimension of which exceeds 3 times the minimum dimension, may not constitute more than 2% of the material by weight. The filter pack for wells installed in unconsolidated material shall be sized to retain at least 50% of the surrounding formation based on a sieve analysis. In formations which are predominantly silt and clay, the filter pack shall be a fine sand. In bedrock, the filter pack shall be a medium or coarse sand or gravel. Crushed limestone, dolomite or any material containing clay or any other material that will adversely impact on the performance of the monitoring well may not be used as filter pack.

(2) INSTALLATION. The filter pack shall extend from 6 inches beneath the bottom of the well point to 2 feet above the top of the well screen. For water table observation wells constructed in areas where the depth to water table is less than 57 feet, the required filter pack height above the top of the well screen may be reduced to 6 inches to allow for the required amount of annular space sealant to be placed. To ensure that the filter pack is installed evenly surrounding the well screen and casing over the proper depth interval, a tape measure, measuring rod or similar device shall be used to measure the height of the filter pack. The tape measure, measuring rod or similar device shall be carefully raised and lowered while the filter pack is being installed to identify bridging. If bridging occurs the filter pack material shall be tamped into place, surrounding the well screen and casing, using a measuring rod or similar device.

(3) COLLAPSED FORMATION. Collapsed formation may be used as filter pack material ~~if the physical and chemical properties of the formation are consistent with the filter pack specifications stated in sub. (1) and if the collapsed formation will limit the passage of formation fines into the well screen.~~ if the collapsed formation will limit the passage of formation fines into the well screen and either an artificial filter pack cannot be installed or the formation grain size is greater than or equal to fine sand sized grains. The grain size distribution of the collapsed formation shall be such that at least 50 90% of the formation will be retained by the well screen based on a field sieve analysis. ~~If used as filter pack, the collapsed formation shall be visibly free of clay, dust and micaceous and organic matter.~~ Analysis of the collapsed formation for specific gravity and particle size shall be performed during well

~~construction~~ and documentation shall be submitted to the department to support its use as an acceptable filter pack. Following review of the submitted information, the department may require new well construction if the collapsed formation analysis is not consistent with the filter pack specifications ~~in sub. (1) and this subsection.~~

SECTION 13. NR 141.13(1) and (2)(a)(intro.), 1, 2 and 3 and (b)1 and 4 and (3) are amended to read:

NR 141.13(1) FILTER PACK SEAL. (a) Specifications. All permanent groundwater monitoring wells installed with filter packs shall be constructed with a filter pack seal. For all water table observation wells and piezometers, the filter pack seal shall extend 2 feet upward from the top of the filter pack and shall consist of 2 feet of clean fine sand. When high-solids grout, granular bentonite slurry, bentonite-cement grout or neat cement grout is used as the annular space sealant, 2 5 feet of bentonite shall be placed on top of the clean fine sand seal. Bentonite chips no greater than 3/8 inch in diameter or bentonite pellets shall be used for seals placed below the water table. Granular bentonite shall be used for seals placed above the water table. Bentonite granules may be used for seals when there is no standing water above the filter pack and the borehole is less than 25 feet or in areas where the depth to water table is less than 7 feet. For water table observation wells constructed in areas where the depth to water table is less than 16 feet, the filter pack seal shall be reduced to 2 feet of bentonite to allow for the required amount of annular space sealant to be placed. For water table observation wells constructed in areas where the depth to water table is less than 7 feet, the required filter pack seal may be reduced to allow for the required amount of annular space sealant to be placed.

(b) Installation. A tape measure, measuring rod or similar device shall be used to ensure that the filter pack seal is installed over the proper depth interval. The tape measure, measuring rod or similar device shall be carefully raised and lowered while the filter pack seal material is being placed to ~~indentify~~ identify bridging. If bridging occurs the filter pack seal material shall be tamped into place, surrounding the well casing, using a measuring rod or similar device. When a tremie pipe is used to place the filter pack seal the procedures of s. NR 141.10(2) shall be followed. Bentonite pellets, bentonite chips or bentonite granules shall be hydrated in 2 foot lifts as placed in the borehole when placed above the water table.

(2)(a) Specifications. All permanent groundwater monitoring wells shall be installed with an annular space seal designed to achieve a permeability of  $1 \times 10^{-7}$  centimeters per second or less. For permanent groundwater monitoring wells constructed with filter packs, the annular space seal shall extend from the filter pack seal to the ground surface seal and shall be at least

2 feet in length. For water table observation wells constructed in areas where the depth to water table is less than 7 feet, the annular space seal shall be bentonite granules. For monitoring wells constructed into bedrock formations and without well screens, the annular space seal shall extend from the bottom of the outer borehole to the ground surface seal and shall be at least 2 feet in length. Sealant materials may not contain additives. These requirements may be met by:

Note: The department does not recommend the use of neat cement grout or cement mixtures in fractured formations because they may impact water quality.

1. ~~Granular bentonite~~Bentonite granules slurry may be used as an annular space sealant in any type of monitoring well except where the depth to the water table is less than 7 feet.

2. Bentonite sand slurry may be used as an annular space sealant in any type of monitoring well except where the depth to the water table is less than 7 feet.

3. Bentonite pellets, bentonite chips or ~~granular bentonite granules~~ may be used to seal the annular space under the following conditions:

a. ~~Granular bentonite~~Bentonite granules may be used when there is no standing water in the well above the filter pack seal and the total well depth is less than 25 feet or the depth to water table is less than 7 feet.

b. Bentonite chips with diameter no larger than 3/8 inch or bentonite pellets may be used when the depth of standing water in the well is less than 30 feet and the total depth of the annular space seal is less than 50 feet except where the depth to the water table is less than 7 feet.

(b) Installation. 1. When bentonite chips with diameter no larger than 3/8 inch, bentonite pellets or granules are used to seal the annular space, they may either be poured freely down the borehole or added through a tremie pipe, provided the specifications of par. (a) are met. ~~When a tremie pipe, provided the specifications of par. (a) are met.~~ When a tremie pipe is used to place the annular space sealant the procedures of s. NR 141.10(2)(a) and (b) shall be followed.

4. The top of the well ~~caasing~~ casing shall be covered with a protective cap.

(3) GROUND SURFACE SEAL AND PROTECTIVE COVER PIPE. (a) Ground surface seal. All permanent groundwater monitoring wells shall be constructed with a bentonite or concrete ground surface seal. The ground surface seal shall extend to a minimum of 60 inches below the land surface, and the top shall be sloped away from the well casing. If bentonite is used, the top of the surface seal shall terminate ~~at~~ 2 inches below the land surface and shall be covered with top soil or native soil to prevent drying out. The ground surface seal shall be installed around the protective cover and may not be placed between the protective

cover pipe and the well casing. If the monitoring well depth is such that both a minimum 2 foot annular space seal and a minimum 5 foot ground surface seal cannot both be placed, the ground surface seal may be shortened.

Note: Certain soils are prone to frost heave and the department does not recommend use of concrete as a ground surface seal in these situations.

(b) Protective cover pipe. The protective cover pipe shall consist of a metal casing at least 2 inches larger in diameter than the well casing with a locking cap. The protective cover pipe shall extend from the bottom of the ground surface seal to a minimum of 24 inches above the ground surface except as provided in sub. (4). ~~If the monitoring well is located in a floodplain, the protective cover pipe shall be watertight.~~ There may be no more than 4 inches between the top of the well casing and the top of the protective cover pipe. The protective cover pipe shall always extend above the top of the well casing. For water table observation wells constructed in areas where the depth to water table is less than 7 feet, the required length of protective cover shall be reduced and may not extend through the annular space seal or into the filter pack. If the monitoring well is located in a floodplain, the protective cover pipe shall be watertight. The department may require additional protective devices, such as rings of brightly colored posts around the well, as necessary. Weep holes or vents may be used in protective cover pipes.

SECTION 14. NR 141.13(2)(a)4 is repealed and recreated to read:

NR 141.13(2)(a)4. High-solids grout approved by the department, bentonite-cement grout or neat-cement grout may be used to seal the annular space in which a bentonite filter pack seal has been placed except where the depth to the water table is less than 7 feet.

SECTION 15. NR 141.13(2)(a)5 and 6 are repealed:

SECTION 16. NR 141.13(4) is created to read:

NR 141.13(4) GROUND SURFACE SEAL AND FLUSH MOUNTED PROTECTIVE COVER PIPE. (a) Ground surface seal. All permanent groundwater monitoring wells with a flush mounted protective cover pipe shall be constructed with a concrete ground surface seal. The ground surface seal shall extend to, but not beyond, the total depth of the flush mounted protective cover pipe. The ground surface seal shall be installed around the flush mounted protective cover pipe and may not be placed between the flush mounted protective cover pipe and the well casing.

(b) Flush mounted protective cover pipe. The flush mounted protective cover pipe may be installed only in high vehicular traffic areas and may not be installed in areas subject to ponding or flooding. The flush mounted protective cover's lid shall have the wording "monitoring well" on its outer surface. Flush mounted protective cover pipes shall be installed through an impervious surface such as asphalt or concrete. If an impervious surface does not exist one shall be created which will support the weight of the traffic in the area. The flush mounted protective cover pipe shall consist of a watertight metal casing with an inside diameter at least 4 inches greater than the inside diameter of the monitoring well casing. The flush mounted protective cover pipe shall be one continuous metal piece or two metal pieces which are joined with a continuous weld. The flush mounted protective cover pipe shall be a minimum of 12 inches in length. There may be no more than 8 inches between the top of the monitoring well casing and the top of the flush mounted protective cover pipe after installation. The flush mounted protective cover pipe shall have an exterior flange or lugs. The flush mounted protective cover pipe may not extend beyond the annular space seal. The flush mounted protective cover pipe or the monitoring well shall have a locking mechanism. The monitoring well installed within any flush mounted protective cover pipe shall have a watertight cap.

Note: Figure 4 depicts 2 typical flush mounted protective cover pipes after installation.

Note: An exterior flange or lugs will aid in the stabilization of the flush mounted protective cover pipe within the ground surface seal.

Note: After removing the watertight cap and prior to taking a pressure head measurement a waiting period is recommended to enable the water level to stabilize.

SECTION 17. NR 141.13(4)(b) Figure 4 is created to read:

**Figure 4.**  
Two typical flush mounted protective cover pipes  
after installation.

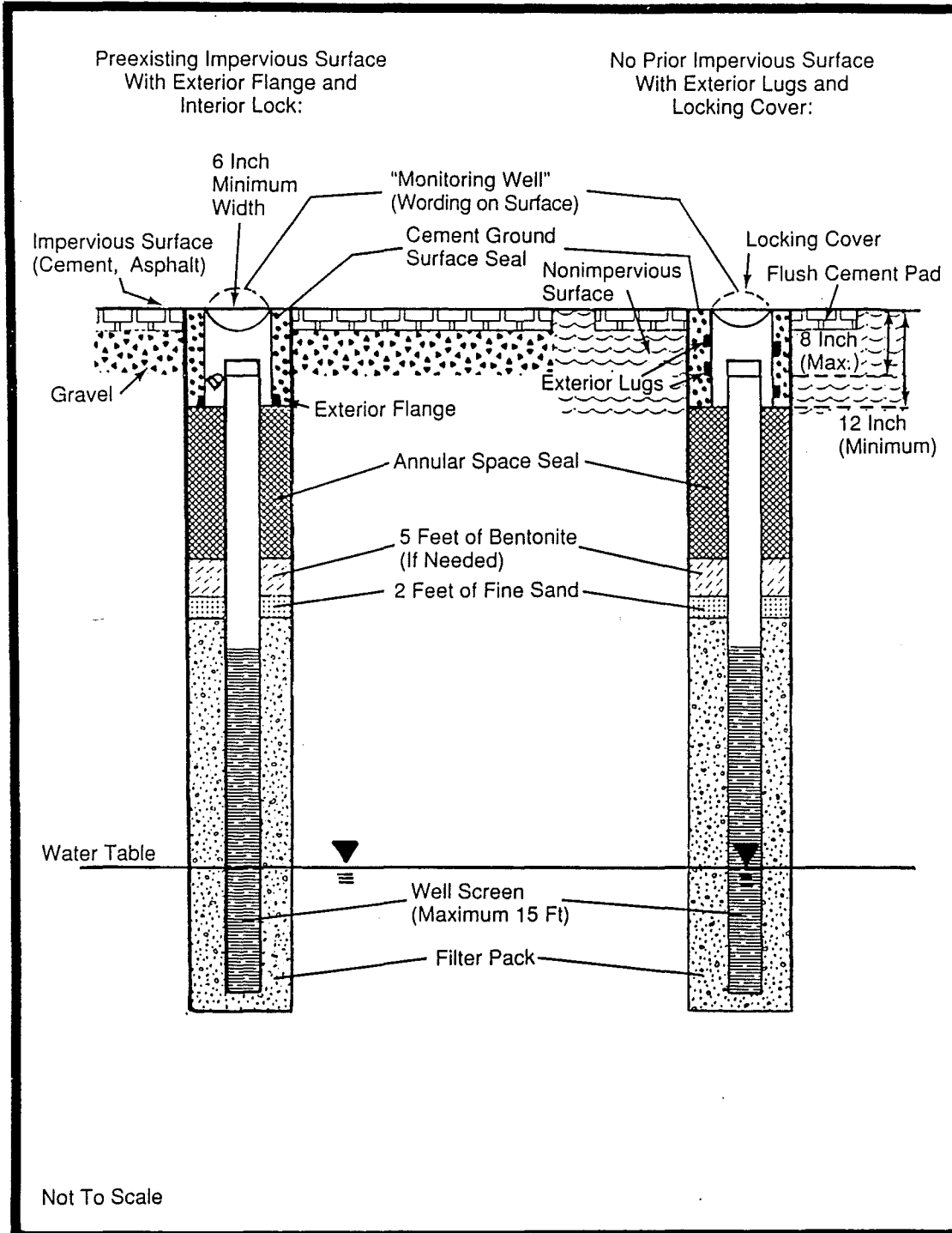

SECTION 18. NR 141.16 is created to read:

NR 141.16 CROSS CONTAMINATION. Precautions shall be taken to prevent cross contamination of aquifers or uncontaminated zones.

SECTION 19. NR 141.19(1)(c)(note) is created to read:

Note: The dual-tube or triple-tube reverse rotary systems are rotary methods.

SECTION 20. NR 141.20 is created to read:

NR 141.20 AQUIFER TEST OR RECOVERY WELLS. The installation, location and construction of any aquifer test well or recovery well installed for a purpose regulated by the department under ch. 144, 147 or 160, Stats., shall be approved by the department program responsible for overseeing work at the site prior to installation. Unless another time period is specified by law, the department shall complete its review and make a determination on all applications for approval within 65 business days after receipt of the complete application for approval. Applications may be included with other submittals for work to be performed at the site. The start of the 65 day review period will not begin until a complete application is received by the department. All requests for approval shall be in writing, except that for situations that require immediate response, an approval may be requested verbally and an advanced verbal approval may be granted by the department and followed up with a written confirmation. Aquifer test wells or recovery wells may be used for pressure head monitoring or water quality monitoring only with the approval of the department. All aquifer test and recovery wells shall be abandoned according to s. NR 141.25 and documented according to s. NR 141.23.

Note: See ch. NR 112 for additional requirements that apply to aquifer test wells and recovery wells.

SECTION 21. NR 141.21(intro.), (1)(a) and (b) and (2) are amended to read:

NR 141.21 WELL DEVELOPMENT. All permanent groundwater monitoring wells shall be developed according to the requirements of this section. Wells sealed with grout or slurry shall be developed after a minimum waiting period of 12 hours after installation is completed ~~and before the initial water quality samples are taken.~~ The goal of well development is to produce water free of sediment and all drill cuttings and drilling fluids.

(1)(a) Alternately surge and purge the well for a minimum of 30 minutes. The surge and purge cycle shall consist of several



minutes of surging followed by several minutes of purging to remove the material collecting in the bottom of the well. The surging shall move formation water in and out of the well screen. ~~The surging shall move formation water in and out of the well screen.~~ The surging shall be accomplished by using either a bailer or surge block or by pumping the well sufficiently to cause a drawdown and then allowing the well to recover and repeating the process.

Note: When a surge block is used care should be taken to avoid drawing the annular space seal material into the filter pack or well screen.

(b) After the final surge and purge cycle is completed, the well shall be pumped or bailed until 10 well volumes of water are removed or until the well produces sediment free water. If sediment free water is not obtained any remaining sediment shall be removed from the bottom of the well. Well volume shall be calculated in the following manner:

$V_1 + V_2 = \text{well volume}$

$V_1 = \text{volume of water in well casing}$

$$V_1 = \pi \left(\frac{D_1}{2}\right)^2 H_1 \text{ ft}^3$$

$V_2 = \text{volume of water in filter pack}$

$$V_2 = N \pi H_2 \left[ \left(\frac{D_3}{2}\right)^2 - \left(\frac{D_2}{2}\right)^2 \right]$$

$N = \text{porosity of filter pack}$

$D_1 = \text{inside diameter of well casing}$

$D_2 = \text{outside diameter of well casing}$

$D_3 = \text{diameter of borehole}$

$H_1 = \text{height of water column}$

$H_2 = \text{length of sand used in filter pack and fine sand filter pack seal or the height of the water column in water table observation wells.}$

Note: There are 7.48 gallons per cubic foot.

CALCULATION OF WELL VOLUME

IN WATER TABLE OBSERVATION WELL

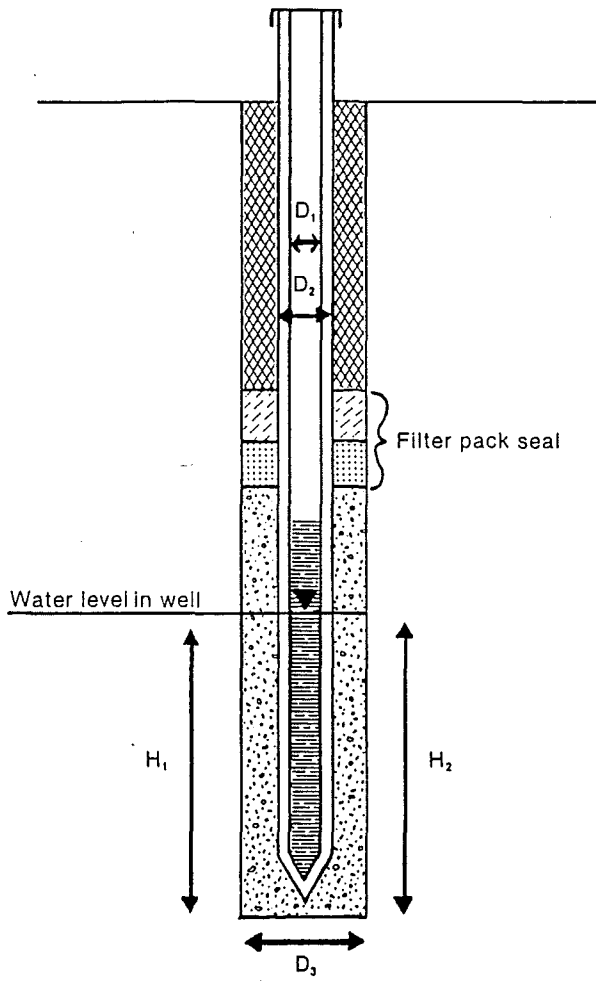

IN PIEZOMETER

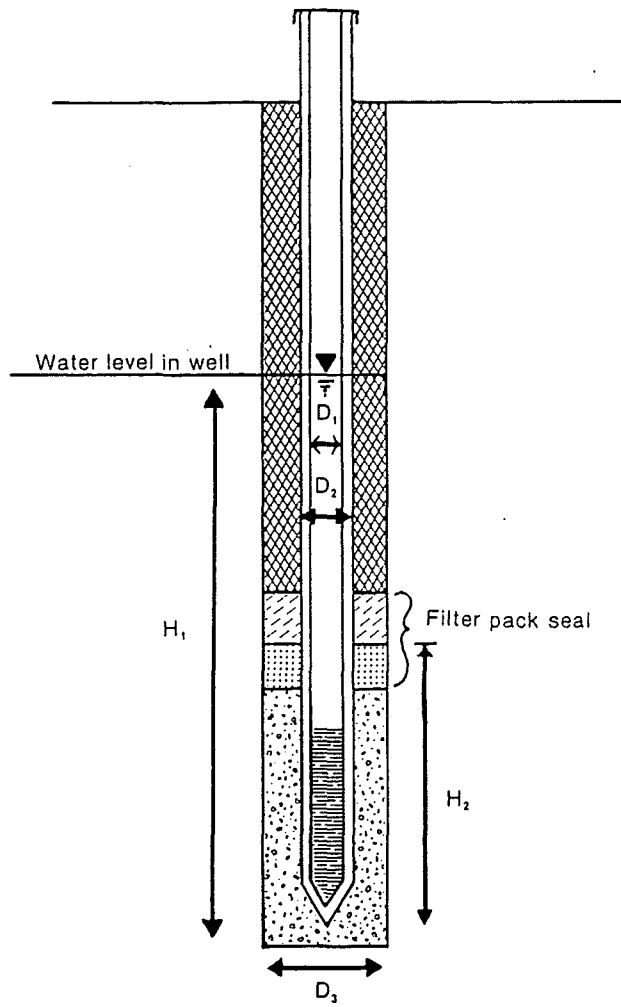

(2) WELLS THAT CAN BE PURGED DRY. All permanent groundwater monitoring wells that can be purged dry shall be developed in a manner which limits agitation by slowly purging the well dry. Wells which can be purged dry may not be surged and no water may be added to the well. ~~The development procedure is complete when 5 volumes of well water have been removed or when the well produces sediment free water.~~

SECTION 22. NR 141.23(1)(h) is amended to read:

NR 141.23(1)(h) Well development procedures, ~~and~~

SECTION 23. NR 141.23(1)(i) is renumbered to NR 141.23(1)(j):

SECTION 24. NR 141.23(1)(i) is created to read:

NR 141.23(1)(i) Sieve analysis, and

SECTION 25. NR 141.25(2)(b), (2)(d)1 to 3 and (3) are amended to read:

NR 141.25(2)(b) Monitoring wells - impermeable annular space seals. A permanent groundwater monitoring well known to be constructed with an impermeable annular space seal shall be abandoned according to the requirements of par. (d) after the protective cover pipe and ground surface seal have been removed and the well casing cut off at least ~~4 feet~~ 30 inches below the ground surface. The well casing may be completely removed during abandonment by pulling the well casing, overdrilling around the casing and then pulling the well casing out of the ground or by drilling out the well casing completely. If the well casing is to be removed, the well shall be sealed as the casing is removed.

(2)(d)1. ~~Granular bentonite~~ Bentonite granules may be used for abandonment of boreholes and groundwater monitoring wells less than 25 feet deep and when there is no standing water above the filter pack seal.

2. Bentonite chips no greater than 3/8 inch in diameter or bentonite pellets may be used for abandonment of boreholes and groundwater monitoring wells less than 50 feet deep and the depth of standing water is less than 30 feet.

3. Bentonite chips no greater than 3/8 inch in diameter or bentonite pellets may be used for abandonment of boreholes and groundwater monitoring wells which are greater than 4 inches in diameter and less than 250 feet deep and the depth of standing water is less than 150 feet.

(3) SEALANT SETTLEMENT. Any settling of the sealant material shall be topped off. Sealing material may be terminated ~~4 feet~~ 30 inches below the ground surface in agricultural areas to avoid interference with agricultural activities. A native

soil plug shall be placed on top of the settled sealing material in such cases.

The foregoing rules were approved and adopted by the State of Wisconsin Natural Resources Board on February 28, 1991.

The rules shall take effect on the first day of the month following publication in the Wisconsin administrative register as provided in s. 227.22(2)(intro.), Stats.

Dated at Madison, Wisconsin April 30, 1991

STATE OF WISCONSIN  
DEPARTMENT OF NATURAL RESOURCES

By Carroll D. Besadny  
Carroll D. Besadny, Secretary

(SEAL)

RECEIVED  
7 1991  
Revisor of Statutes  
Bureau