

Chapter E 240

OVERCURRENT PROTECTION

E 240.01	Scope	E 240.19	Arcing or suddenly-moving parts
E 240.02	Purpose of overcurrent protection	E 240.20	Plug fuses of the Edison-base type
E 240.03	Protection of equipment	E 240.21	Fuseholders for plug fuses
E 240.04	Time-delay overcurrent protection	E 240.22	Plug fuses and fuseholders of type S
E 240.05	Overcurrent protection of conductors	E 240.23	Cartridge fuses and fuseholders
E 240.06	Fuses	E 240.24	Link fuses and fuseholders
E 240.07	Non-adjustable-trip circuit-breakers	E 240.25	Circuit-breakers
E 240.08	Thermal devices	E 240.27	Current limiting overcurrent protective device
E 240.09	Feeders at supply stations	E 240.28	Table—Number of overcurrent units, such as trip coils or relays, for protection of circuits
E 240.11	Ungrounded conductors	E 240.30	Purpose
E 240.12	Grounded conductor	E 240.31	Location
E 240.13	Change in size of grounded conductor	E 240.32	Accessibility
E 240.14	Fuses in multiple	E 240.33	Interrupting capacity
E 240.15	Location in circuit	E 240.34	Interchangeability
E 240.16	Location in premises	E 240.35	Rating
E 240.17	Enclosures for overcurrent devices		
E 240.18	Disconnection of fuses and thermal cutouts before handling		

A. INSTALLATION

E 240.01 **Scope.** This chapter provides the general requirements for the application of overcurrent protective devices.

History: Cr. Register, November, 1961, No. 71, eff. 12-1-61.

E 240.02 **Purpose of overcurrent protection.** Overcurrent protection for conductors and equipment is provided for the purpose of opening the electric circuit if the current reaches a value which will cause an excessive or dangerous temperature in the conductor or conductor insulation.

History: Cr. Register, November, 1961, No. 71, eff. 12-1-61.

E 240.03 **Protection of equipment.** Equipment shall be protected against overcurrent as specified in the references in the following table:

Equipment	Chapter No.
Appliances -----	E 422
Capacitors -----	E 460
Cranes and Hoists -----	E 610
Elevators, Dumbwaiters and Escalators -----	E 620
Emergency Systems -----	E 700
Generators -----	E 445
Inductive and Dielectric Heat Generating Equipment -----	E 665
Machine Tools -----	E 670
Motion Picture Studios and Similar Locations -----	E 530
Motors and Motor Controllers -----	E 430

Organs	E 650
Over 600 Volts	E 710
Remote-Control, Low-Energy Power, Low-Voltage Power and Signal Circuits	E 725
Services	E 230
Signs and Outline Lighting	E 600
Sound Equipment	E 640
Switchboards and Panelboards	E 384
Theaters and Assembly Halls	E 520
Transformers	E 450
Welders	E 630
X-ray Equipment	E 660

History: Cr. Register, November, 1961, No. 71, eff. 12-1-61.

E 240.04 Time-delay overcurrent protection. Circuit-breakers and plug fuses installed in residential occupancies on circuits of 20 amperes or less shall be of the time-delay type.

History: Cr. Register, November, 1961, No. 71, eff. 12-1-61.

E 240.05 Overcurrent protection of conductors. Conductors shall be protected in accordance with their current-carrying capacities, as given in tables E 310.12 through E 310.15, except as follows:

(1) **EXCEPTION No. 1. RATING OF OVERCURRENT PROTECTION.** When the standard ampere ratings and settings of overcurrent devices do not correspond with the allowable current-carrying capacities of conductors, the next higher standard rating and setting may be used.

(2) **EXCEPTION No. 2. ADJUSTIBLE-TRIP CIRCUIT-BREAKERS.** Adjustable-trip circuit-breakers of the thermal trip, magnetic time-delay trip or instantaneous-trip types shall be set to operate at not more than 125% of the allowable current-carrying capacity of the conductor.

Note: The effect of the temperature on the operation of thermally-controlled circuit-breakers should be taken into consideration in the application of such circuit-breakers when they are subjected to extremely low or extremely high temperatures.

(3) **EXCEPTION No. 3. FIXTURE WIRES AND CORDS.** Fixture wire or flexible cord, sizes No. 16 or No. 18, and tinsel cord shall be considered as protected by 20-ampere overcurrent devices except as provided in section E 620.61. Fixture wires of the sizes permitted for taps in subsection E 210.19 (3) (b) shall be considered as protected by the overcurrent protection of the 30-ampere and 50-ampere branch circuits of chapter E 210. Flexible cord approved for use with specific appliances shall be considered as protected by the overcurrent device of the branch circuit of chapter E 210 when conforming to the following:

- 20 ampere circuits, No. 18 cord and larger.
- 30 ampere circuits, cord of 10 amperes capacity and over.
- 50 ampere circuits, cord of 20 amperes capacity and over.

(4) **EXCEPTION No. 4. MOTOR CIRCUITS.** The conductors supplying motors and motor-operated appliances shall be considered as protected by the overcurrent protective devices specified in sections E 430.032, E 430.034, E 430.052, E 430.053 and E 430.062.

(5) **EXCEPTION No. 5. REMOTE CONTROL.** Except as provided in chapter E 725, the conductors of the control circuits of remote-control switches shall be considered as protected from overcurrent by over-

current devices that are not of the so-called time-lag type and are rated or set at not more than 500% of the carrying capacity of the remote-control conductors, as specified in tables E 310.12 through E 310.15.

(6) **EXCEPTION No. 6.** Public highway traffic signal circuits whose conductors are not overloaded may be protected by overcurrent devices rated or set at not more than 200% of the carrying capacity of the conductors, as specified in tables E 310.12 through E 310.15.

History: Cr. Register, November, 1961, No. 71, eff. 12-1-61.

E 240.06 Fuses. (1) If the allowable current-carrying capacity of a conductor does not correspond to the rating of a standard-size fuse, the next larger size or rating of fuse may be used.

(2) Standard ampere ratings for fuses are 15, 20, 25, 30, 35, 40, 45, 50, 60, 70, 80, 90, 100, 110, 125, 150, 175, 200, 225, 250, 300, 350, 400, 450, 500, 600, 800, 1000, 1200, 1600, 2000, 2500, 3000, 4000, 5000, and 6000. Fuses with ampere rating other than the standard rating listed may be used when they are of an ampere rating smaller than those included in the standard list.

(3) Plug fuses and fuseholders shall not be used in circuits exceeding 125 volts between conductors except in circuits supplied from a system having a grounded neutral and no conductor in such circuits operating at more than 150 volts to ground.

(4) The screw-shell of plug-type fuseholders shall be connected to the load side of the circuit.

History: Cr. Register, November, 1961, No. 71, eff. 12-1-61.

E 240.07 Non-adjustable-trip circuit-breakers. (1) Non-adjustable-trip circuit-breakers, except as otherwise permitted in Note 10 to tables E 310.12 through E 310.15 shall be rated in accordance with the current-carrying capacity of the conductor. When the allowable current-carrying capacity of a conductor does not correspond to the rating of a standard-size circuit-breaker, the next larger size or rating of circuit-breaker may be used.

(2) Standard ampere ratings for circuit-breakers are 15, 20, 30, 40, 50, 60, 70, 100, 125, 150, 175, 200, 225, 250, 300, 350, 400, 500, 600, 700 and 800.

History: Cr. Register, November, 1961, No. 71, eff. 12-1-61.

E 240.08 Thermal devices. Thermal cutouts, thermal relays and other devices not designed to open short-circuits, shall not be used for protection of conductors against overcurrent due to short-circuits or grounds but may be used to protect motor branch circuit conductors from overload if protected in accordance with section E 430.040.

History: Cr. Register, November, 1961, No. 71, eff. 12-1-61.

E 240.09 Feeders at supply stations. Each conductor of a constant-potential circuit entering or leaving a supply station, except grounded neutral conductors, shall be protected from excessive current by a circuit-breaker, or by an equivalent device of approved design. Such protective devices shall be located as near as practicable to the point where the conductors enter or leave the building. For the outgoing circuits not connected with other sources of power, the protective devices may be placed on the supply side of transformers or similar devices.

History: Cr. Register, November, 1961, No. 71, eff. 12-1-61.

E 240.11 Ungrounded conductors. (1) An overcurrent device (fuse or overcurrent trip unit of a circuit-breaker) shall be placed in each ungrounded conductor. The number and position of the overcurrent units such as trip coils or relays shall be as given in table E 240.28.

(2) Circuit-breakers shall open all ungrounded conductors of the circuit, except as follows:

(a) *Exception:* Individual single-pole circuit-breakers may be used for the protection of each conductor of ungrounded 2-wire circuits, each ungrounded conductor of 3-wire direct-current or single-phase circuits, or for each ungrounded conductor of lighting or appliance branch circuits connected to 4-wire 3-phase systems, or 5-wire 2-phase systems, provided such lighting or appliance circuits are supplied from a system having a grounded neutral and no conductor in such circuits operates at a voltage greater than permitted in section E 210.06.

History: Cr. Register, November, 1961, No. 71, eff. 12-1-61.

E 240.12 Grounded conductor. No overcurrent device shall be placed in any permanently grounded conductor, except as follows:

(1) EXCEPTION No. 1. Where the overcurrent device simultaneously opens all conductors of the circuit.

(2) EXCEPTION No. 2. For motor-running protection as provided in sections E 430.036 and E 430.037.

History: Cr. Register, November, 1961, No. 71, eff. 12-1-61.

E 240.13 Change in size of grounded conductor. Where a change occurs in the size of the ungrounded conductor, a similar change may be made in the size of the grounded conductor.

History: Cr. Register, November, 1961, No. 71, eff. 12-1-61.

E 240.14 Fuses in multiple. For the protection of conductors having allowable carrying capacities exceeding the rated capacity of the largest approved cartridge type fuse in subsection E 240.23 (1) (a), such cartridge fuses arranged in multiple may be used, provided as few fuses as possible are used and the fuses are of the same type, characteristics, and rating and provided the fuseholder terminals are mounted on a single continuous pair of bus-bars, or have an equivalent arrangement that will eliminate any potential difference between the terminals of the fuses.

History: Cr. Register, November, 1961, No. 71, eff. 12-1-61.

B. LOCATION

E 240.15 Location in circuit. Overcurrent devices shall be located at the point where the conductor to be protected receives its supply, except as follows:

(1) EXCEPTION No. 1. SERVICE CONDUCTORS. An overcurrent protective device for service conductors may be located as specified in section E 230.091.

(2) EXCEPTION No. 2. SMALLER CONDUCTOR PROTECTED. Where the overcurrent device protecting the larger conductors also protects the smaller conductors in accordance with tables E 310.12 through E 310.15.

(3) **EXCEPTION No. 3. BRANCH CIRCUITS.** Taps to individual outlets and circuit conductors supplying a single household electric range shall be considered as protected by the branch circuit overcurrent devices when in accordance with the requirements of sections E 210.19 and E 210.20.

(4) **EXCEPTION No. 4. TAPS.** A conductor tapped from a feeder shall be considered as properly protected from overcurrent when installed in accordance with sections E 210.25, E 364.08 and E 430.058.

(5) **EXCEPTION No. 5. TAPS NOT OVER 10 FEET LONG.** Where (a) the smaller conductor has a current-carrying capacity of not less than the sum of the allowable current-carrying capacities for the conductors of the one or more circuits or loads supplied, and (b) the tap is not over 10 feet long and does not extend beyond the switchboard, panelboard, or control devices which it supplies, and (c) except at the point of connection to the feeder, the tap is enclosed in conduit, electrical metallic tubing, or in metal gutters when not a part of the switchboard or panelboard.

(6) **EXCEPTION No. 6. TAPS NOT OVER 25 FEET LONG.** Where the smaller conductor has a current-carrying capacity at least one-third that of the conductor from which it is supplied, and provided the tap is suitably protected from physical damage, is not over 25 feet long, and terminates in a single circuit-breaker or set of fuses which will limit the load on the tap to that allowed by tables E 310.12 through E 310.15. Beyond this point the conductors may supply any number of circuit-breakers or sets of fuses.

History: Cr. Register, November, 1961, No. 71, eff. 12-1-61.

E 240.16 Location in premises. Overcurrent devices shall be located where they will be:

(1) Readily accessible, except as provided in section E 230.091 for service equipment, E 364.11 for busways, and E 610.42 for cranes and hoists.

(2) Not exposed to physical damage.

(3) Not in the vicinity of easily ignitable material.

History: Cr. Register, November, 1961, No. 71, eff. 12-1-61.

C. ENCLOSURES

E 240.17 Enclosures for overcurrent devices. (1) **GENERAL.** Overcurrent devices shall be enclosed in cutout boxes or cabinets, unless a part of a specially approved assembly which affords equivalent protection, or unless mounted on switchboards, panelboards or controllers located in rooms or enclosures free from easily ignitable material and dampness. The operating handle of a circuit-breaker may be accessible without opening a door or cover.

(2) **DAMP OR WET LOCATIONS.** Enclosures for overcurrent devices in damp or wet locations shall be of a type approved for such locations and shall be mounted so there is at least one-fourth inch air space between the enclosure and the wall or other supporting surface.

(3) **VERTICAL POSITION.** Enclosures for overcurrent devices shall be mounted in a vertical position unless in individual instances this is shown to be impracticable.

(4) **ROSETTES.** Fuses shall not be mounted in rosettes.

History: Cr. Register, November, 1961, No. 71, eff. 12-1-61.

D. DISCONNECTING AND GUARDING

E 240.18 Disconnection of fuses and thermal cutouts before handling. Disconnecting means shall be provided on the supply side of all fuses or thermal cutouts in circuits of more than 150 volts to ground and cartridge fuses in circuits of any voltage, where accessible to other than qualified persons, so that each individual circuit containing fuses or thermal cutouts can be independently disconnected from the source of electrical energy, except as provided in section E 230.073 and except that a single disconnecting means may be used to control a group of circuits each protected by fuses or thermal cutouts under the conditions described in section E 430.112.

History: Cr. Register, November, 1961, No. 71, eff. 12-1-61.

E 240.19 Arcing or suddenly-moving parts. Arcing or suddenly-moving parts shall comply with the following:

(1) **LOCATION.** Fuses and circuit-breakers shall be so located or shielded that persons will not be burned or otherwise injured by their operation.

(2) **SUDDENLY-MOVING PARTS.** Handles or levers of circuit-breakers, and similar parts which may move suddenly in such a way that persons in the vicinity are liable to be injured by being struck by them, shall be guarded or isolated.

History: Cr. Register, November, 1961, No. 71, eff. 12-1-61.

E. PLUG FUSES AND FUSEHOLDERS

E 240.20 Plug fuses of the Edison-base type. Plug fuses of the Edison-base type shall conform to the following:

(1) **CLASSIFICATION.** Plug fuses of this type shall be classified at not over 125 volts, 0 to 30 amperes.

(2) **LIVE PARTS.** Fuses and fuseholders when installed and assembled together shall have no live parts exposed.

(3) **MARKING.** Plug fuses of 15 amperes rating or less shall be distinguished from those of larger rating by an hexagonal opening in the cap through which the mica or similar window shows, or by some other prominent hexagonal feature such as the form of the top or cap itself, or an hexagonal recess or projection in the top or cap.

History: Cr. Register, November, 1961, No. 71, eff. 12-1-61.

E 240.21 Fuseholders for plug fuses. Fuseholders for plug fuses of 30 amperes or less shall not be installed unless they comply with section E 240.22 or are made to comply with section E 240.22 by the insertion of an adapter.

History: Cr. Register, November, 1961, No. 71, eff. 12-1-61.

E 240.22 Plug fuses and fuseholders of type S. Where type S plug fuses are to be used as the overcurrent device required by this code, the fuses and fuseholders shall conform to the following requirements:

(1) **CLASSIFICATION.** Plug fuses and fuseholders of type S shall be classified at not over 125 volts; 0 to 15 amperes, 16 to 30 amperes.

(2) **FUSES USABLE ONLY IN FUSEHOLDERS OF THE SAME CLASSIFICATION.** Fuses of the 16 to 30 ampere classification shall not be usable with fuseholders or adapters of the 0 to 15 ampere classification.

(3) FUSEHOLDERS AND ADAPTERS. Fuses, fuseholders, and adapters shall be so designed that a fuse other than a type S fuse cannot be used in a fuseholder or adapter designed for type S fuses.

(4) TAMPERABILITY. Fuses, fuseholders and adapters shall be so designed as to be subject to tampering or bridging only with difficulty.

(5) ADAPTERS TO BE NON-REMOVABLE. Fuse adapters shall be so designed that when once inserted in a fuseholder they cannot be removed.

(6) INTERCHANGEABILITY. Fuses, fuseholders and adapters of various manufacturers shall be interchangeable with each other, and the plugs with adapters shall be suitable for use in the Edison-base type fuseholder.

(7) PLUG TYPE. Fuses and fuseholders shall be of the plug type.

(8) AMPERE RATING. Each fuse, fuseholder and adapter shall be marked with its ampere rating.

(9) MARKING. Fuses of the 0 to 15 ampere rating shall be distinguished from those of larger rating by an hexagonal opening in the cap through which the mica or similar window shows, or some other prominent hexagonal feature such as the form of the top or cap itself, or an hexagonal recess or projection in the top or cap.

History: Cr. Register, November, 1961, No. 71, eff. 12-1-61.

F. CARTRIDGE FUSES AND FUSEHOLDERS

E 240.23 Cartridge fuses and fuseholders. Cartridge fuses and fuseholders shall conform to the following:

(1) CLASSIFICATION. (a) 0-600 ampere cartridge fuses and fuseholders shall be classified as regards current and voltage as follows:

Not over 250 volts Amperes	Not over 600 volts Amperes
0-30	0-30
31-60	31-60
61-100	61-100
101-200	101-200
201-400	201-400
401-600	401-600

(b) 601-6000 ampere cartridge fuses and fuseholders shall be classified at 600 volts as follows:

601- 800 amperes
801-1200
1201-1600
1601-2000
2001-3000
3001-4000
4001-5000
5001-6000

Note: There are no 250 volt ratings over 600 amperes, but 600 volt fuses may be used for lower voltages.

(2) NON-INTERCHANGEABLE. 0-6000 ampere cartridge fuses and fuseholders shall be so designed that it will be impossible to put a fuse of any given class into a fuseholder which is designed for a

current lower, or voltage higher, than that of the class to which it belongs. Fuseholders for current limiting fuses shall not permit insertion of fuses which are not current limiting.

(3) **MARKING.** Fuses shall be plainly marked with the ampere rating, the voltage rating, the current-limitation where it applies, and the name or trademark of the maker. The marking shall be either by direct printing on the fuse barrel or by means of an attached label.

History: Cr. Register, November, 1961, No. 71, eff. 12-1-61.

G. LINK FUSES AND FUSEHOLDERS

E 240.24 Link fuses and fuseholders. Link fuses and fuseholders shall be used only by special permission and shall conform to the following:

(1) **MOUNTING.** Link fuses shall be mounted on approved fuseholders.

(2) **DIMENSIONS.** Link fuses and fuseholders shall have the following dimensions in inches:

Amperes Capacity	Minimum Separation of Nearest Metal Parts of Opposite Polarity	Minimum Break Distance
Not over 125 volts		
601-1500.....	1½	1½
Not over 250 volts		
601-1500.....	2¾	2

(a) For 3-wire systems, link fuses, and fuseholders shall have the break distance required for circuits of the potential of the outside wires, except that in 125-250 volt systems with grounded neutral the fuses and fuseholders in 2-wire, 125 volt branch circuits may have the spacing specified for not over 125 volts.

(3) **SPACING.** A space shall be maintained between the fuse terminals of link fuses of the same polarity of at least ½ inch for voltages up to 125, and of at least ¾ inch for voltages from 126 to 250. This is the minimum distance allowable and greater separation shall be provided where practicable.

(4) **MATERIAL.** Contact surfaces on tops of link fuses shall be of copper or aluminum having good electrical connections with the fusible part of the strip.

(5) **MINIMUM RATING.** Link fuses and fuseholders shall be used only in sizes rated at more than 600 amperes, and only by special permission.

(6) **MARKING.** Link fuses shall be stamped with 80% of the maximum current which they can carry indefinitely.

History: Cr. Register, November, 1961, No. 71, eff. 12-1-61.

H. CIRCUIT-BREAKERS

E 240.25 Circuit-breakers. Circuit-breakers shall conform to the following:

Electrical Code, Volume 2
Register, November, 1961, No. 71

(1) **METHOD OF OPERATION.** In general, circuit-breakers shall be capable of being closed and opened by hand without employing any other source of power, although normal operation may be by other power such as electrical, pneumatic, and the like. Large circuit-breakers which are to be closed and opened by electrical, pneumatic, or other power shall be capable of being closed by hand for maintenance purposes and shall also be capable of being tripped by hand under load without the use of power.

(2) **TYPE OF OPERATION.** Circuit-breakers of the 0-30 ampere class should be of the time-delay type.

(3) **INJURY TO OPERATOR.** Circuit-breakers shall be arranged and mounted so that their operation is not likely to injure the operator.

(4) **INDICATION.** Circuit-breakers shall indicate whether they are in the open or closed position.

(5) **NON-TAMPERABLE.** An air circuit-breaker, used for the branch circuits described in chapter E 210, shall be of such design that any alteration of its trip point (calibration), or in the time required for its operation, will be difficult.

(6) **MARKING.** Circuit-breakers shall be marked with their rating in such a manner that the marking will be visible after installation.

(7) **NON-INTERCHANGEABLE CIRCUIT-BREAKERS.** Circuit-breakers used for lighting and appliance branch circuits shall be non-interchangeable in accordance with the following provisions:

(a) Circuit-breakers rated within the range of 0-250 volts, alternating current and not more than 100 amperes shall be classified as regards current as follows:

Amperes
0- 20
21- 50
51-100

(b) Such circuit-breakers or their multiple mounting and bussing means shall be so arranged that it will be difficult, after a circuit-breaker has been installed, to replace it with a breaker of a higher ampere classification.

(c) Such circuit-breakers of higher than 0-20 ampere classification shall be difficult to install in the spare spaces which are left for future additions.

History: Cr. Register, November, 1961, No. 71, eff. 12-1-61.

E 240.27 Current limiting overcurrent protective device. A current limiting overcurrent protective device is a device which, when interrupting a specified circuit, will consistently limit the short-circuit current in that circuit to a specified magnitude substantially less than that obtainable in the same circuit if the device were replaced with a solid conductor having comparable impedance.

History: Cr. Register, November, 1961, No. 71, eff. 12-1-61.

TABLE E 240.28

NUMBER OF OVERCURRENT UNITS, SUCH AS TRIP COILS OR RELAYS, FOR PROTECTION OF CIRCUITS

(See diagrams 1 to 19 following this table)
(See section E 240.11 for the overcurrent protection of conductors in general, section E 230.090 for services, and section E 430.037 for motors)

SYSTEMS	*Number and Location of Overcurrent Units
2-Wire, Single-phase A.C. or D.C. Ungrounded.	Two (one in each conductor, Diagram 1).
2-wire, Single-phase, A.C. or D.C., One Wire Grounded.	One (in ungrounded conductor, Diagram 2).
2-Wire, Single-phase A.C. or D.C., Mid-point Grounded.	Two (one in each conductor, Diagram 3).
2-Wire, Single-phase A.C. Derived from 3-Phase, with Ungrounded Neutral.	Two (one in each conductor, Diagram 4).
2-Wire, Single-phase. Derived from 3-Phase, Grounded Neutral System by Using Outside Wires of 3-Phase Circuit.	Two (one in each conductor, Diagram 5).
3-Wire, Single-phase, A.C. or D.C. Ungrounded Neutral.	Three (one in each conductor, Diagram 6).
3-Wire, Single-phase A.C. or D.C. Grounded Neutral.	Two (one in each conductor except neutral conductor, Diagram 7).
3-Wire, 2-Phase, A.C. Common Wire Ungrounded.	Three (one in each conductor, Diagram 8).
3-Wire, 2-Phase, A.C., Common Wire Grounded.	Two (one in each conductor except common conductor, Diagram 9).
4-Wire, 2-Phase Ungrounded, Phases Separate.	Four (one in each conductor, Diagram 10).
4-Wire, 2-Phase, Grounded Neutral, or 5-Wire, 2-Phase, Grounded Neutral.	Four (one in each conductor except neutral conductor, Diagrams 11 and 12).
3-Wire, 3-Phase, Ungrounded.	Three (one in each conductor, Diagram 13**).
3-Wire, 3-Phase, 1 Wire Grounded.	Two (one in each ungrounded conductor, Diagram 14).
3-Wire, 3-Phase, Grounded Neutral.	Three (one in each conductor, Diagram 15**).
3-Wire, 3-Phase, Mid-point of One Phase Grounded.	Three (one in each conductor, Diagram 17**).
4-Wire, 3-Phase, Grounded Neutral.	Three (one in each ungrounded conductor, Diagram 18**).
4-Wire, 3-Phase, Ungrounded Neutral.	Four (one in each conductor, Diagram 19).

Notes to Table E 240.28

*1. An overcurrent unit may consist of a series overcurrent tripping device or the combination of a current transformer and a secondary overcurrent tripping device. Either 2 or 3 secondary overcurrent tripping devices may be used with 3 current transformers on a 3-phase system similar to those shown in diagrams 15 and 18.

**2. When 3 current transformers are used instead of 3 series overcurrent tripping devices shown in diagrams 13, 15, 17 and 18, the secondary tripping devices may consist of 3 secondary overcurrent tripping devices or 2 secondary overcurrent tripping devices with a residual current tripping device of a lower range. See diagram 16.

3. Where standard devices are not available with 3 or 4 overcurrent units as required in the table, it is permissible to substitute 2 overcurrent units and one fuse where 3 overcurrent units are called for, 2 overcurrent units and 2 fuses where 4 overcurrent units are called for. The fuse or fuses are to be placed in the conductors not containing an overcurrent unit. This practice, however, of substituting fuses for overcurrent units is to be discouraged for obvious reasons.

History: Cr. Register, November, 1961, No. 71, eff. 12-1-61.

DIAGRAMS E 240.29

Diagrams 1 to 19 showing number of overcurrent units such as trip coils or relays for the protection of circuits as required by table E 240.28.

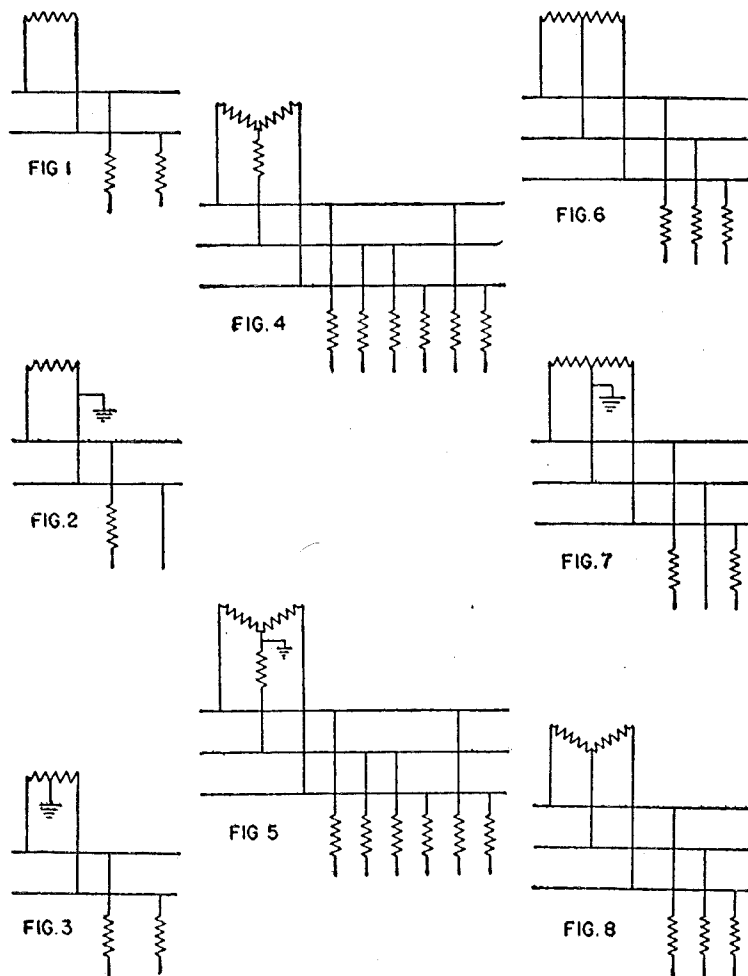

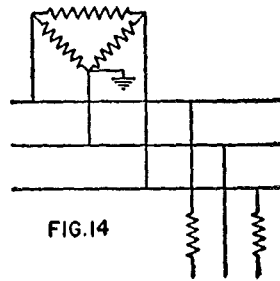
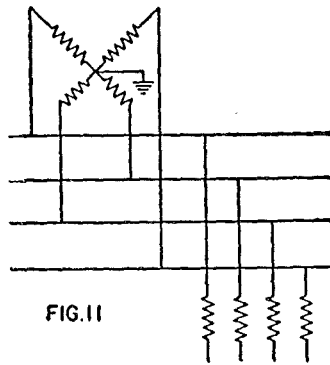
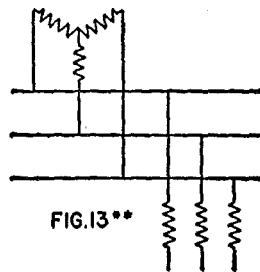
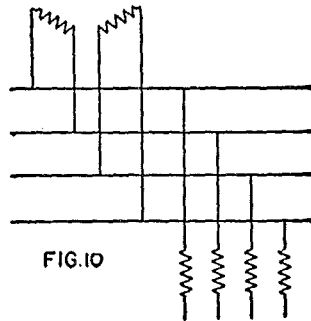
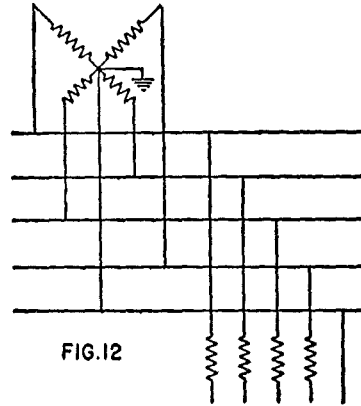
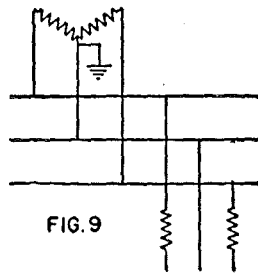

** See Note 2 of Table E 240.28.

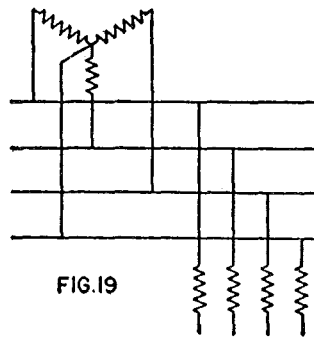
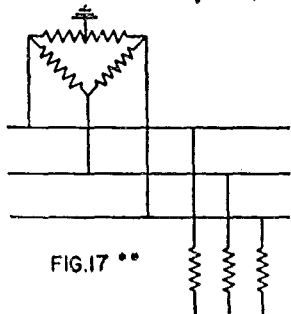
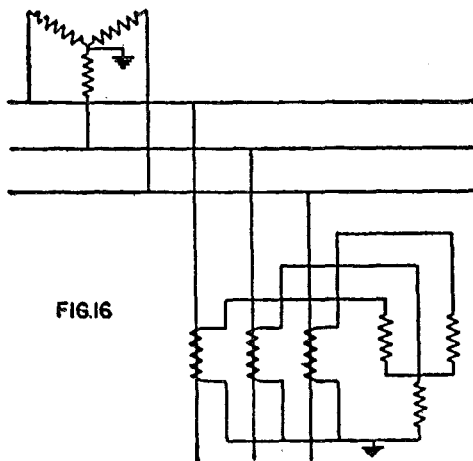
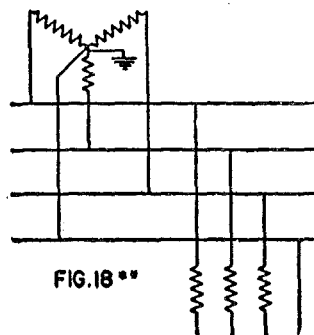
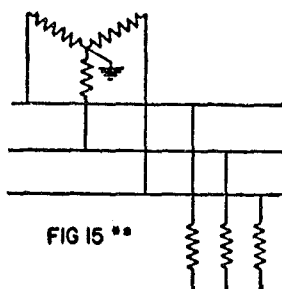

** See Note 2 of Table E 240.23.

History: Cr. Register, November, 1961, No. 71, eff. 12-1-61.

I. SUPPLEMENTARY OVERCURRENT PROTECTION

E 240.30 Purpose. Supplementary overcurrent protection may be included in appliances or other utilization equipment to provide individual protection for specific components, or internal circuits within the equipment itself. It does not abrogate any of the requirements applicable to branch circuits and is not to be used as a substitute for branch-circuit protection.

History: Cr. Register, November, 1961, No. 71, eff. 12-1-61.

E 240.31 Location. Supplementary overcurrent devices, where provided, shall be located in each separate appliance or other equipment and shall not extend to circuits beyond the confines of the equipment.

History: Cr. Register, November, 1961, No. 71, eff. 12-1-61.

E 240.32 Accessibility. Supplementary overcurrent protective devices need not be readily accessible.

History: Cr. Register, November, 1961, No. 71, eff. 12-1-61.

E 240.33 Interrupting capacity. Supplementary overcurrent protective devices shall be able to interrupt short-circuit currents of the magnitude likely to be encountered by the branch circuit overcurrent protective device protecting that circuit.

History: Cr. Register, November, 1961, No. 71, eff. 12-1-61.

E 240.34 Interchangeability. Supplementary overcurrent protective devices are not required to be interchangeable with branch circuit overcurrent protective devices.

History: Cr. Register, November, 1961, No. 71, eff. 12-1-61.

E 240.35 Rating. Supplementary overcurrent protective devices shall be rated at not more than 15 amperes.

History: Cr. Register, November 1961, No. 71, eff. 12-1-61.