

SECTION 231. Appendix A-82.20 (2) is repealed and recreated to read:

A-82.20 (2) AGENT MUNICIPALITIES. The department has designated the following municipalities the authority to review and approve plumbing plans and specifications for those plumbing installations located within the boundary limits of the municipality and which require approval under s. Comm 82.20.

Note: This list is maintained by the department and is subject to change.

Appleton, City of
100 N. Appleton St.
Appleton, WI 54911-4799
Phone (920) 832-6419
FAX (920) 832-6464

Kenosha, City of
Dept. of Housing
625 52nd St., Rm. 100
Kenosha, WI 53144
Phone (262) 653-4263
FAX (262) 653-4254

Eau Claire, City of
203 S. Farwell St.
Eau Claire, WI 54702
Phone (715) 839-4947
FAX (715) 839-4939

Madison, City of
215 Martin Luther King Jr. Blvd.
PO Box 2984
Madison, WI 53701-2984
Phone (608) 266-4561
FAX (608) 266-6377

Green Bay, City of
100 N. Jefferson St., Rm. 403
Green Bay, WI 54301
Phone (920)448-3296
FAX (920) 448-3117

Milwaukee, City of
Municipal Bldg., Rm. 1017
809 N. Broadway St.
Milwaukee, WI 53202
Phone (414) 286-3116
FAX (414) 286-8667

Greenfield, City of
7325 W. Forest Home Ave.
Greenfield, WI 53220
Phone (414) 329-5328
FAX (414) 543-9615

Oak Creek, City of
Public Works Inspection Div.
8640 S. Howell Ave.
Oak Creek, WI 53154
Phone (414) 768-6547
FAX (414) 768-9587

Janesville, City of
18 N. Jackson St.
P.O. Box 5005
Janesville, WI 53547-5005
Phone (608) 755-3064
FAX (608) 755-3196

Oshkosh, City of
215 Church Ave.
Oshkosh, WI 54901
Phone (920) 236-5052
FAX (920) 236-5084

Racine, City of
730 Washington Ave.
Racine, WI 53403
Phone (262) 636-9164
FAX (262) 636-9298

Sheboygan, City of
City Hall, 3rd Fl.
828 Center Ave.
Sheboygan, WI 53081
Phone (920) 459-3478
FAX (920) 459-3967

SECTION 232. Appendix A-82.30 (4) is repealed and recreated to read:

A-82.30 (4) The following table lists the gallons per minute (GPM) which can be expected to readily flow through a given size trap where the receptor has a height (H) as indicated.

Also listed is a drainage fixture unit (dfu) load which a given size receptor trap may be expected to adequately receive.

Note: A minimum individual 4-inch diameter trap and drain for a commercial type dishwasher is recommended.

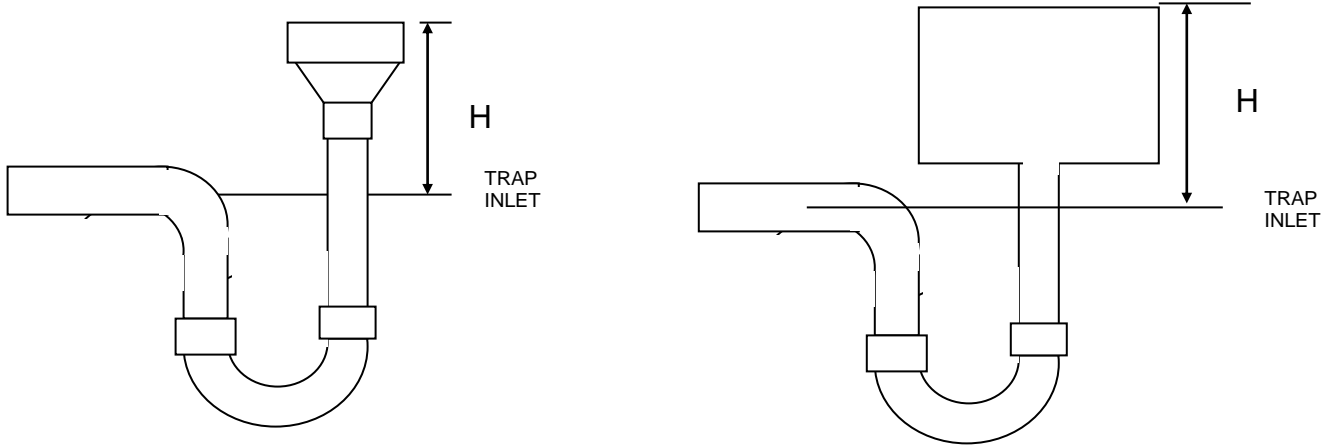

Receptor Trap Size (in inches)	H (in inches)	GPM	Drainage Fixture Units (dfu)
1 ½	12	4	2
2	14	8	4
3	15	12	6
4	17	40	20
5	20	70	35
6	22	120	60
8	25	250	125

SECTION 233. Appendix A-82.30 (4) (d) is created to read:

A-82.30 (4) (d) Section NR 110.13 (2) (c) reads: "**NR 110.13 (2) (c) Slope.** 1. Conventional gravity sewers shall be laid with uniform slope between manholes. All sewers shall be designed and constructed to give average velocities of not less than 60 centimeters per second (2.0 feet per second) when flowing full. The minimum slopes in Table 1 shall be provided. Slopes less than 0.4% may be permitted for 20 centimeter (8 inch) sewers. In such cases, however, the slope may not be less than 0.3%. The department (DNR) will approve these sewers only when the owner demonstrates that physical circumstances warrant the lesser slope. Furthermore, approval will not be granted until the department (DNR) has received written assurance from the operating authority that the authority will provide the additional maintenance which may result from the sedimentation due to decreased velocities."

NR 110 Table 1

Sewer Size (in inches)	Minimum Slope (ft./100 ft.)
8 (20 cm)	0.40
10 (25 cm)	0.28
12 (30 cm)	0.22
15 (38 cm)	0.15
18 (46 cm)	0.12
21 (53 cm)	0.10
24 (61 cm)	0.08

SECTION 234. Appendix A-82.30 (10) (b) 3. is created to read:

A-82.30 (10) (b) 3. VELOCITY AND FLOW RELATIONSHIP MAINTAINING 2 FEET PER SECOND.

**Schedule 40 PVC
VELOCITY AND FLOW RELATIONSHIP
MAINTAINING 2 FEET PER SECOND**

Nominal Inside Diameter (in inches)	Actual Inside Diameter (in inches)	GPM creating 2 ft. per second
1 ¹ / ₄	1.38	9
1 ½	1.61	13
2	2.067	21
3	3.068	46
4	4.026	79

SECTION 235. Appendix A-82.30 (11) (b) is repealed and recreated to read:

A-82.30 (11) (b) BUILDING DRAINS SERVING ANY BUILDING.

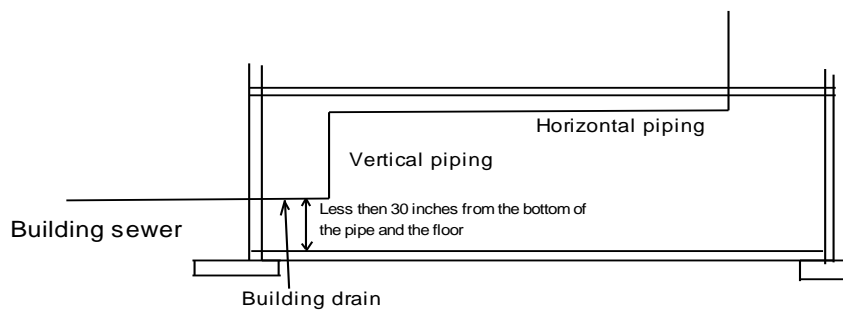
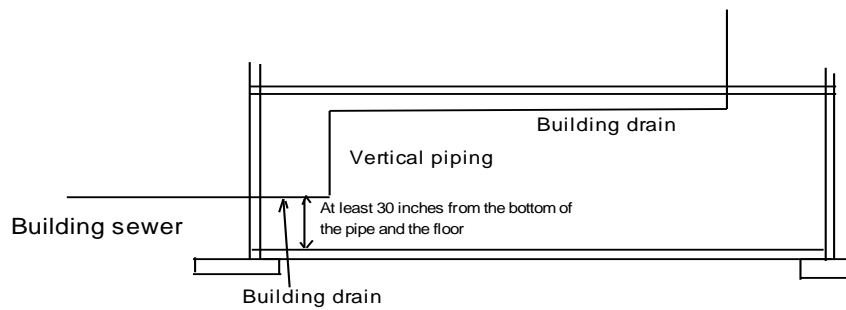
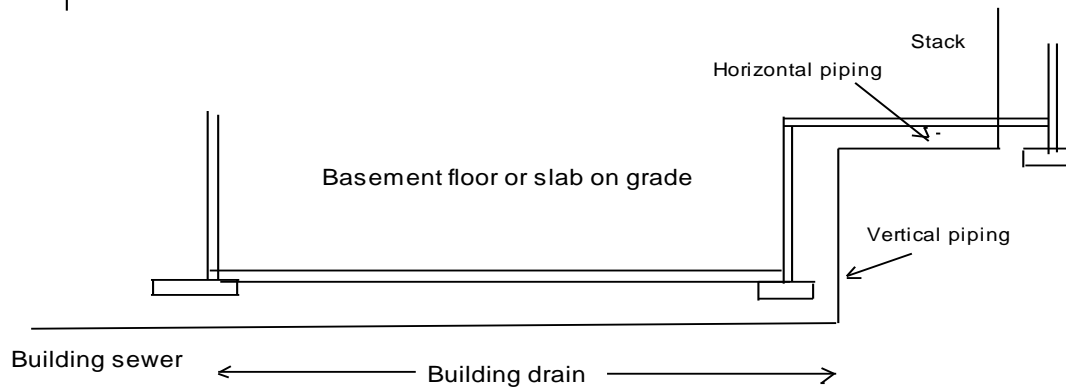
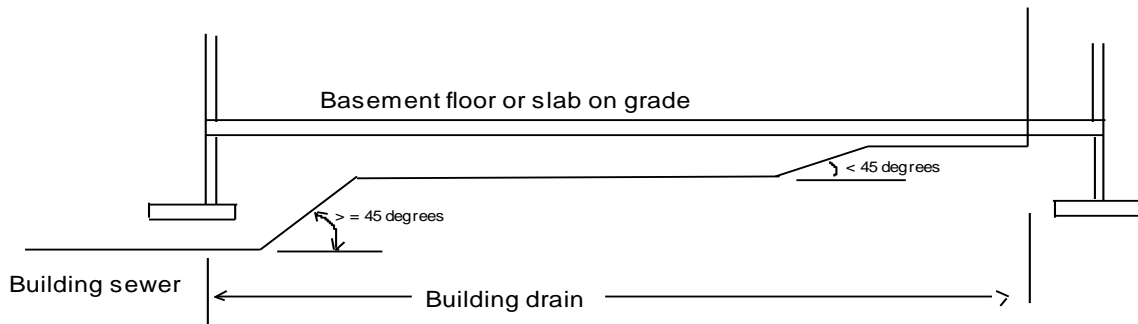

SECTION 236. Appendix A-82.30 (11) (c) is created to read:

A-82.30 (11) (c) BUILDING SEWER INSULATION. Sketch provides an illustration of an acceptable building sewer insulation for Zone C.

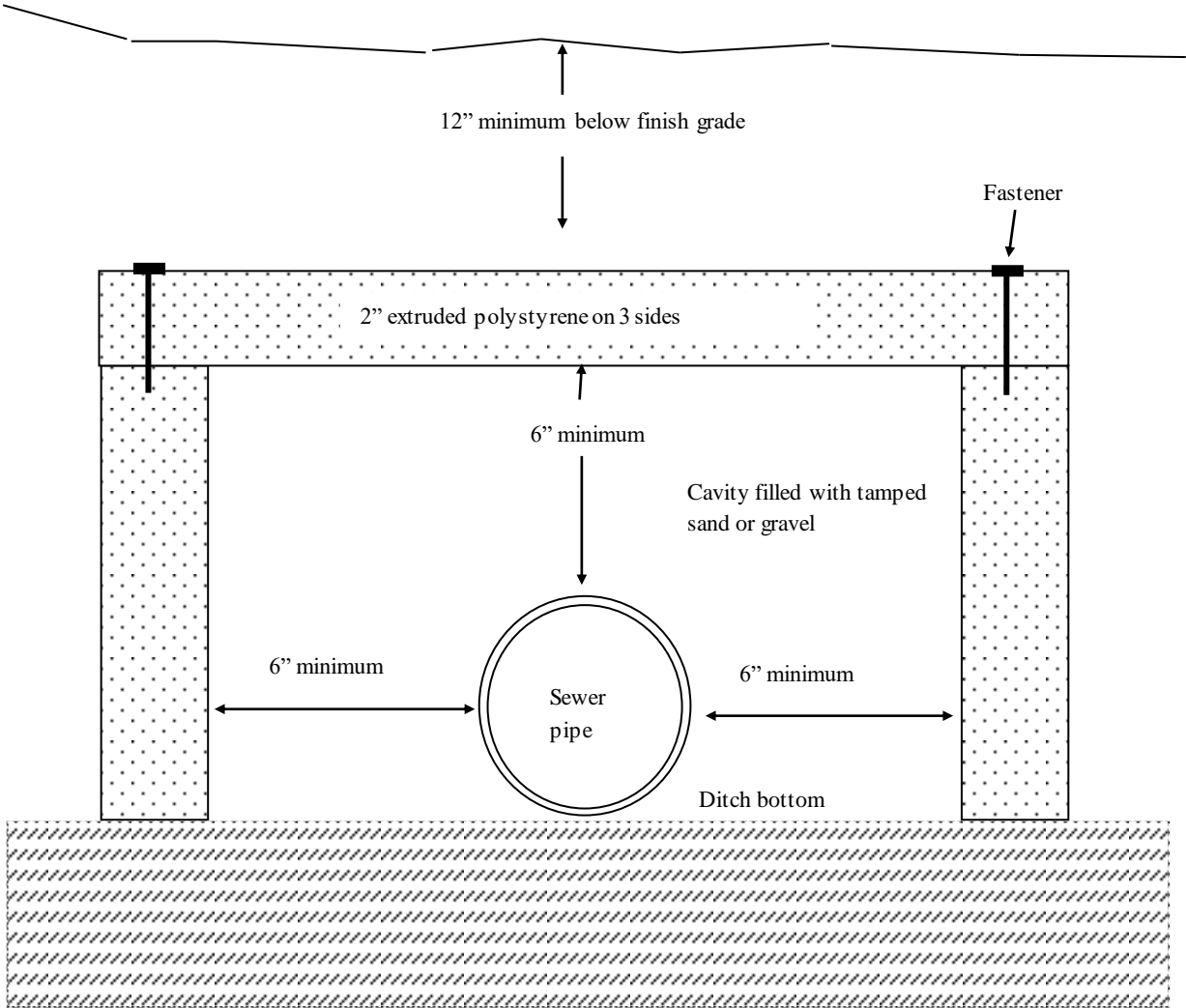

SECTION 237. Appendix A-82.30 (11) (d) is created to read:

A-82.30 (11) (d) SETBACKS FOR VARIOUS CONTAMINANT SOURCES. Setbacks for various contaminant sources as specified in s. NR 812.08 (4) (a) to (e). Section NR 812.08 (4) (a) to (e) reads:

"NR 812.08 (4) RELATION TO CONTAMINATION SOURCES. Minimum separating distances between any new potable or nonpotable well, reservoir or spring and existing sources of contamination; or between new sources of contamination and existing potable or nonpotable wells, reservoirs or springs shall be maintained as described in this subsection. The minimum separating distances of this subsection do not apply to dewatering wells approved under s. NR 812.09 (4) (a). Greater separation distances may be required for wells requiring plan approval under s. NR 812.09. Separation distance requirements to possible sources of contamination will not be waived because of property lines.

Minimum separating distances are listed in Table A and are as follows:

(a) Eight feet between a well or reservoir and a:

1. Buried gravity flow sanitary or storm building drain having pipe conforming to ch. Comm 84;
2. Buried gravity flow sanitary or storm building sewer having pipe conforming to ch. Comm 84;
3. Watertight clear water waste sump;
4. Buried clear water waste drain having pipe conforming to ch. Comm 84;
5. Buried gravity flow foundation drain;
6. Rainwater downspout outlet;
7. Cistern;
8. Buried building foundation drain connected to a clear water waste drain or other subsoil drain;
9. Noncomplying pit, subsurface pumphouse, alcove, or reservoir;
10. Nonpotable well;
11. Fertilizer or pesticide storage tank with a capacity of less than 1,500 gallons, but only when the well is nonpotable;

Note: For potable wells see par. (d) 1.

12. Plastic silage storage and transfer tube;
13. Yard hydrant;
14. Swimming pool, measured to the nearest edge of the water; or
15. Dog or other small pet house, animal shelter or kennel housing not more than 3 adult pets on a residential lot.

(b) Twenty-five feet between a well or reservoir and a:

1. Buried grease interceptor or trap;
2. Septic tank;
3. Holding tank;
4. Buried building drain or building sewer having pipe not conforming to ch. Comm 84, wastewater sump, or non-watertight clear water waste sumps,
5. Buried pressurized sanitary building sewer having pipe conforming to ch. Comm 84;
6. Buried gravity manure sewer;
7. Lake, river, stream, ditch or stormwater detention pond or basin measured to the regional high water elevation in the case of a lake or stormwater detention pond, to the edge of the floodway in the case of a river or stream or to the edge in the case of a ditch or stormwater detention basin;
9. Liquid-tight barn gutter;
10. Animal barn pen with concrete floor;
11. Buried pressurized sewer pipe conveying manure provided that the pipe meets ASTM specification D-2241, with standard dimension ratio of 21 or less or pressure pipe meeting the requirements of s. NR 110.13 (6) (f) or 811.62.
12. Buried fuel oil tanks serving single family residences, including any associated buried piping;
13. Discharge to ground from a water treatment device;
14. Vertical shaft installed below grade used for intake of air for a heating or air conditioning system; or
15. Buried sanitary or storm collector sewer serving 4 or fewer living units or having a diameter of 6 inches or less.

(c) Fifty feet between a well or reservoir and a:

1. Soil absorption unit receiving less than 8,000 gallons/day, existing, abandoned or alternate, but not including a school soil absorption unit;

Note: For school soil absorption units see par. (e); for soil absorption units receiving more than 8,000 gallons/day see par. (f) 3.

2. Privy;
3. Pet waste pit disposal unit;

4. Animal shelter;
5. Animal yard;
6. Silo;
7. Buried sewer used to convey manure having pipe conforming to ch. Comm 84 that does not meet the specifications in par. (b);
8. Liquid tight manure hopper or reception tank;
9. Filter strip;
10. Buried sanitary or storm collector sewer serving more than 4 living units or larger than 6 inches in diameter except that wells may be located or sewers installed such that a well is less than 50 feet, but at least 25 feet, from gravity collector sewers smaller than 16 inches in diameter or from force main collector sewers 4 inches or smaller in diameter provided that within a 50-foot radius of the well the installed sewer pipe meets the allowable leakage requirements of AWWA C600 and the requirements for water main equivalent type pipe as follows:
 - a. For sewers >4" diameter, but <16" diameter: PVC pipe >4" diameter, but <12" diameter shall meet AWWA C900 with elastomeric joints having a standard dimension ratio of 18 or less; PVC pipe >12" diameter, but <16" diameter shall meet AWWA C905 with elastomeric joints having a standard dimension ratio of 18 or less; Ductile iron pipe shall meet AWWA C115 or AWWA C151 having a thickness class 50 or more.
 - b. For sewers <3" diameter, the pipe shall be any rigid pipe in the ch. Comm 84 "Table for Pipe and Tubing for Water Services and Private Water Mains," including approved ABS, brass, cast iron, CPVC, copper (not including type M copper) ductile iron, galvanized steel, polybutylene (PB), polyethylene (PE), PVC, or stainless steel pipe.
11. An influent sewer to a wastewater treatment plant;
12. The nearest existing or future grave site in cemeteries;
13. Wastewater treatment plant effluent pipe;
14. Buried pressurized sewer having pipe not conforming to ch. Comm 84; or
15. Manure loading area.

Note: The minimum separating distance between a well or reservoir and a lift station is based on the presence of a sewer force main at the lift station.

(d) One hundred feet between a well or reservoir and a:

1. Bulk surface storage tank with a capacity greater than 1,500 gallons or any bulk buried storage tank regardless of capacity, including, for both surface or buried tanks, associated buried piping for any solid, semi-solid or liquid product but not including those regulated under par. (b) 12. This subdivision includes, but is not limited to petroleum product tanks, waste oil tanks and pesticide or fertilizer storage tanks not regulated under par. (a) 11. This subdivision does not include septic, holding and manure reception tanks, or liquified petroleum gas tanks as specified in ch. Comm 11.
2. Liquid-tight, fabricated manure or silage storage structure, in ground or at ground surface;
3. Wastewater treatment plant structure, conveyance or treatment unit; or
4. Dry fertilizer or pesticide storage building or area when more than 100 pounds of either or both materials are stored;
5. Well, drill hole or water system used for the underground placement of any waste, surface or subsurface water or any substance as defined in s. 160.01 (8), Stats.;
6. Stormwater infiltration basin;
7. Uncovered storage of silage on the ground surface;
8. Water-tight silage storage trench or pit; or
9. Lift station.

(e) Two hundred feet between a school well and a soil absorption unit receiving less than 8,000 gallons per day, existing or abandoned.

(ee) One hundred fifty feet between a well or reservoir and a temporary manure stack.

(f) Two hundred fifty feet between a well or reservoir and a:

1. Manure stack.
2. Earthen or excavated manure storage structure.

Note: Variances from the separating distances may be granted as specified in s. NR 812.43 for earthen storage and manure stacks constructed and maintained to the specifications of Soil Conservation Standards No. 425 or 312, respectively.

3. Soil absorption unit receiving 8,000 or more gallons per day, existing, abandoned, or alternate.
4. Sludge landspreading or drying area.
5. An earthen silage storage trench or pit.
6. Liquid waste disposal system including, but not limited to a treatment pond or lagoon, ridge and furrow system and spray irrigation system.

Note: Variance from this separating distance may be granted for treatment ponds or lagoons constructed and maintained to an approval granted under ch. NR 213.

7. Salvage yard.

8. A salt or deicing material storage area including the building structure and the surrounding area where the material is transferred to vehicles. This subdivision does not include bagged deicing material.

9. Solid waste processing facility.

10. Solid waste transfer facility.

11. The boundaries of a landspreading facility for spreading of petroleum-contaminated soil regulated under ch. NR 718 while that facility is in operation.

(g) Twelve hundred feet between a well or reservoir and:

1. The nearest edge of an existing, proposed or abandoned landfill, measured to the nearest fill area of abandoned landfills, if known, otherwise measured to the nearest property line;

2. The nearest edge of a coal storage area in excess of 500 tons; or

3. A hazardous waste treatment facility regulated by the department.

SECTION 238. Appendix A-82.33 (8) (c) is renumbered as A-82.33 (8) (d).

[Note to Revisor: There are two A-82.33(8)(c); change the one which has the title: LOCAL WASTEPILING SERVING WATER HEATER RELIEF VALVES to read as A-82.33(8)(d).]

SECTION 239. Appendix A-82.33 (9) (f) is repealed and recreated to read:

A-82.33 (9) (f) ELEVATOR PIT SUBSOIL AND FLOOR DRAINS. Drains and sumps complying with ss. Comm 82.33 and 82.36 shall be provided.

Note: Section Comm 18.23 includes requirements for the installation of drains and sumps. Section Comm 18.23 reads: "Drains and sumps complying with ss. Comm 82.33 and 82.36 shall be provided. Drains connected directly to sanitary drain systems shall not be installed in elevator pits."

ELEVATOR DRAIN DISCHARGE – STORM DRAIN CONNECTION

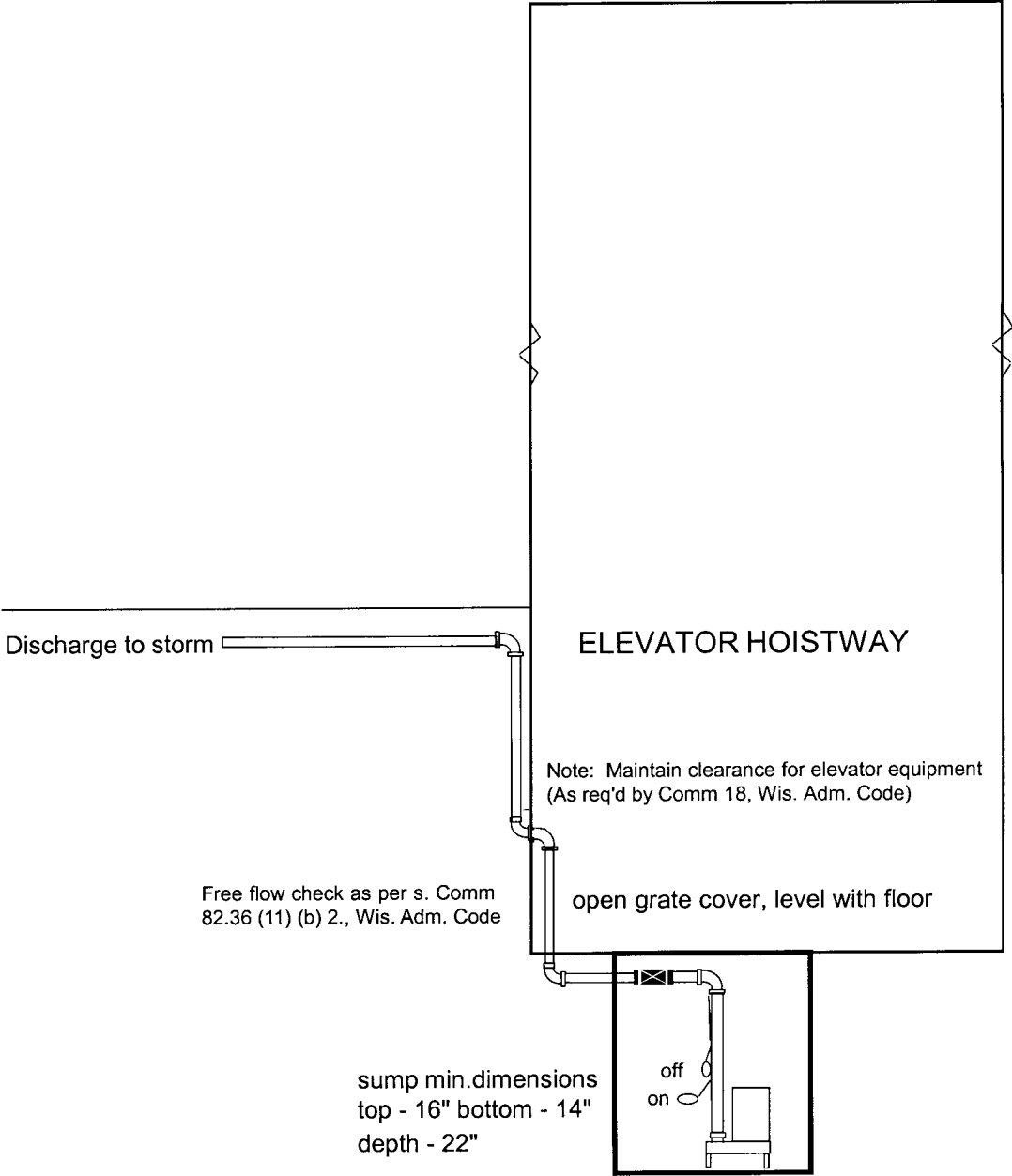

ELEVATOR DRAIN DISCHARGE – STORM DRAIN CONNECTION

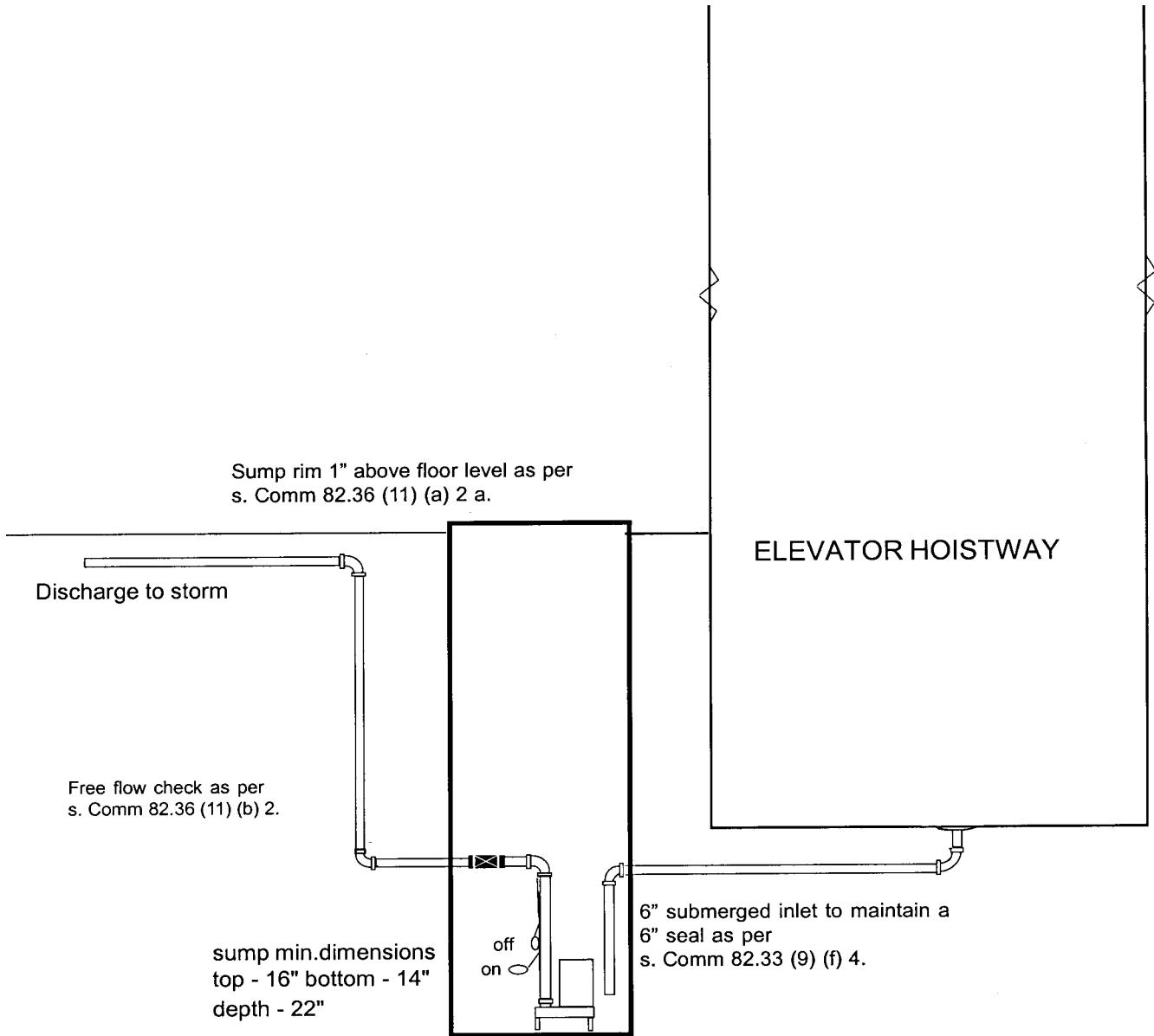

SECTION 240. Appendix A-82.34 (4) is created to read:

A-82.34 (4)-1. GARAGE CATCH BASIN WITH TRAPPED FIXTURES.

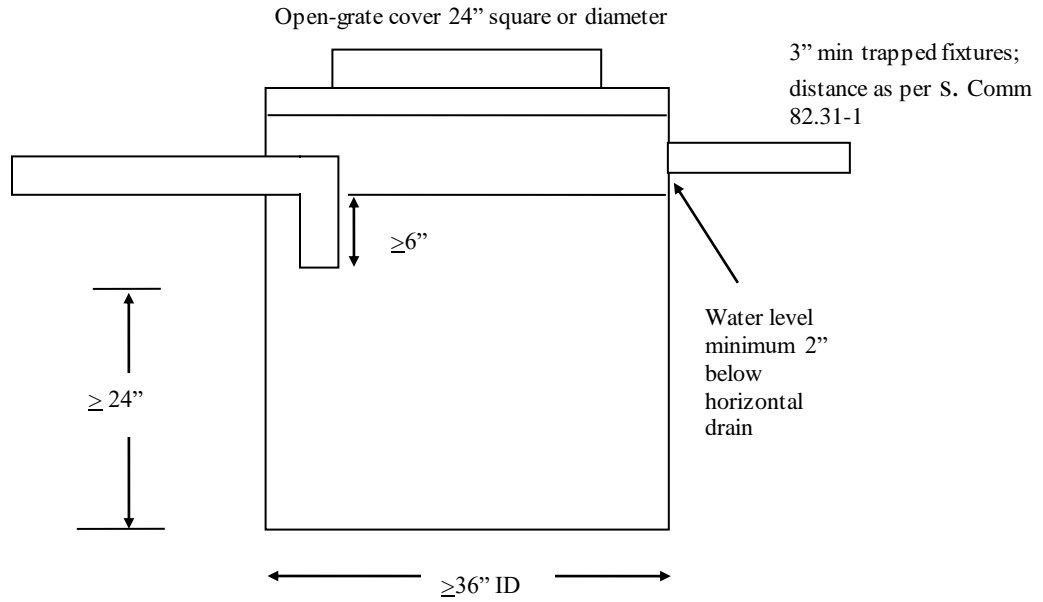

A-82.34 (4)-2. GARAGE CATCH BASIN WITH TRAPPED FIXTURES.

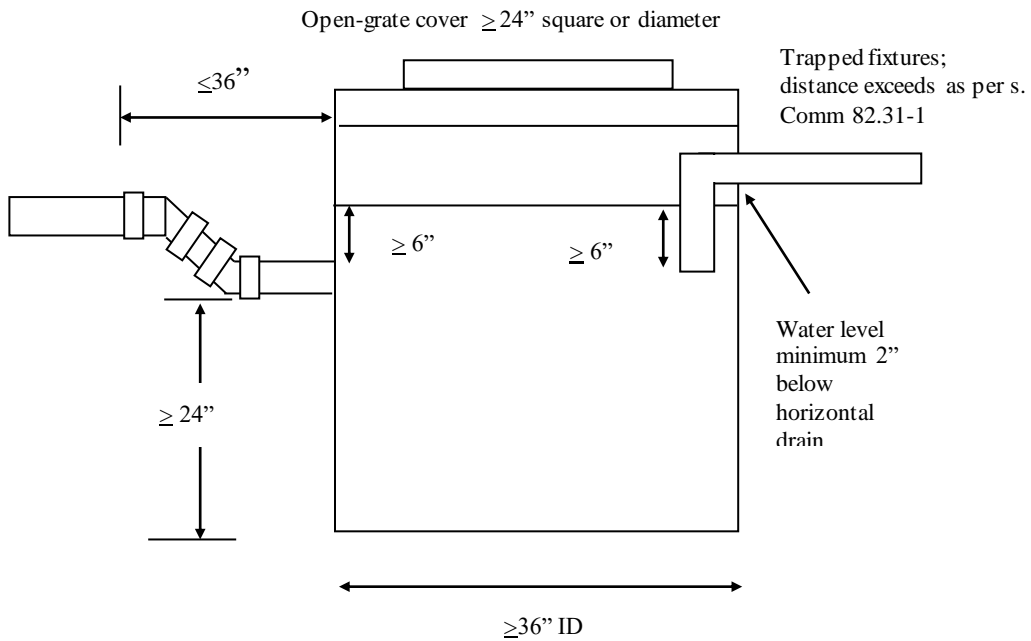

A-82.34 (4)-3. GARAGE CATCH BASIN WITH FIXTURES WITHOUT TRAPS.

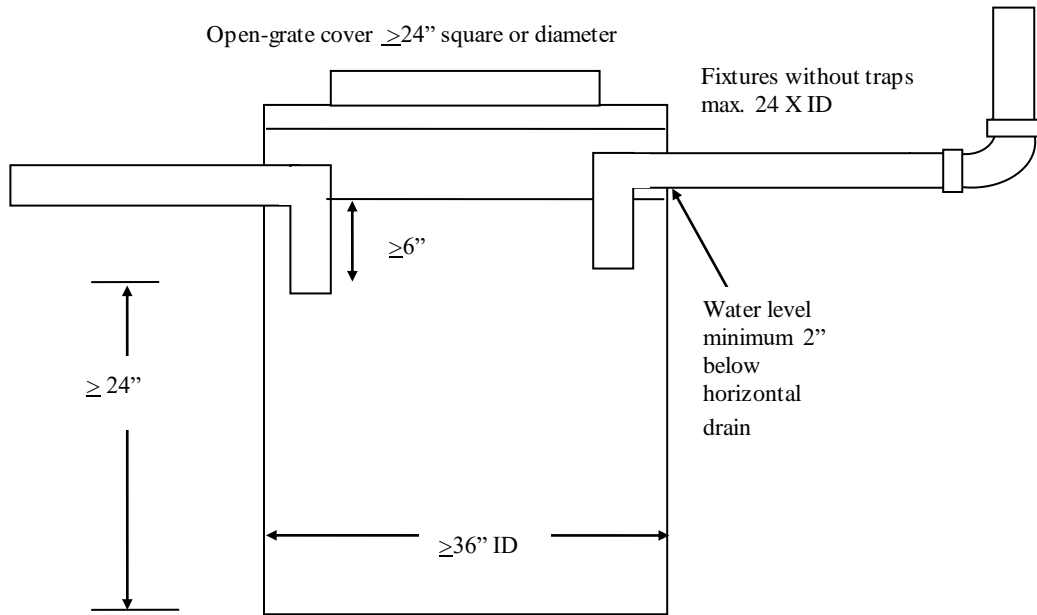

A-82.34 (4)-4. GARAGE CATCH BASIN WITH FIXTURES ON SEPARATE FLOOR LEVELS.

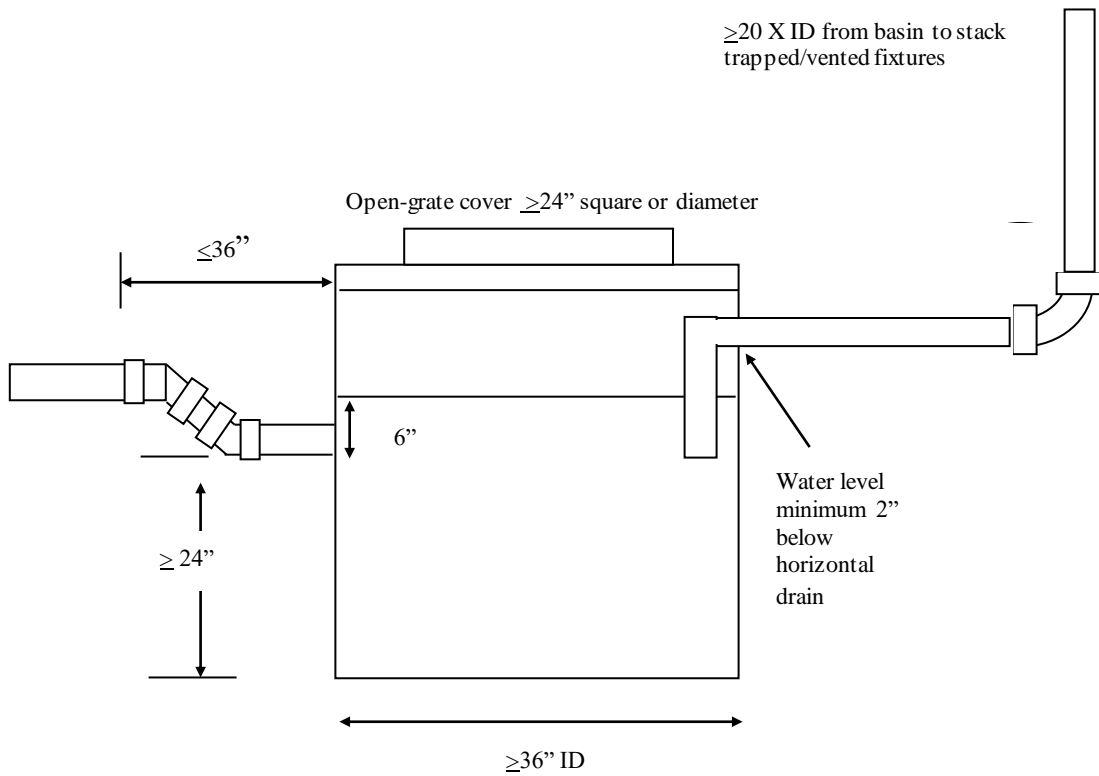

A-82.34 (4)-5. GARAGE CATCH BASIN WITH TRAPPED FIXTURES.

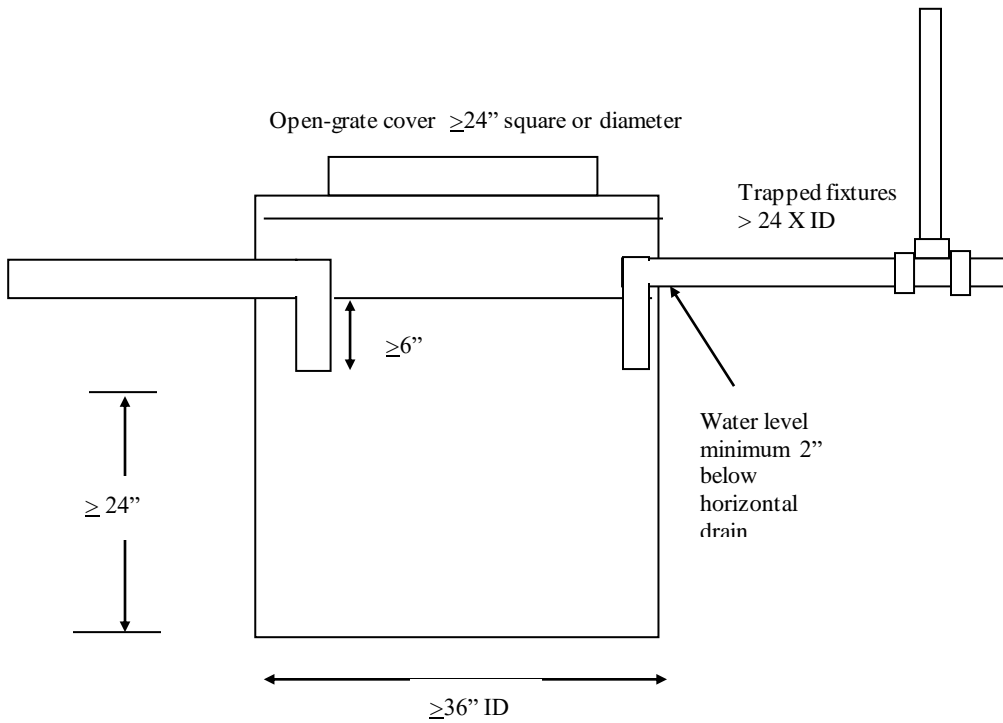

SECTION 241. Appendix A-82.37 (2) is created:

A-82.37 (2) CONCRETE PADS FOR DUMPSTATIONS.

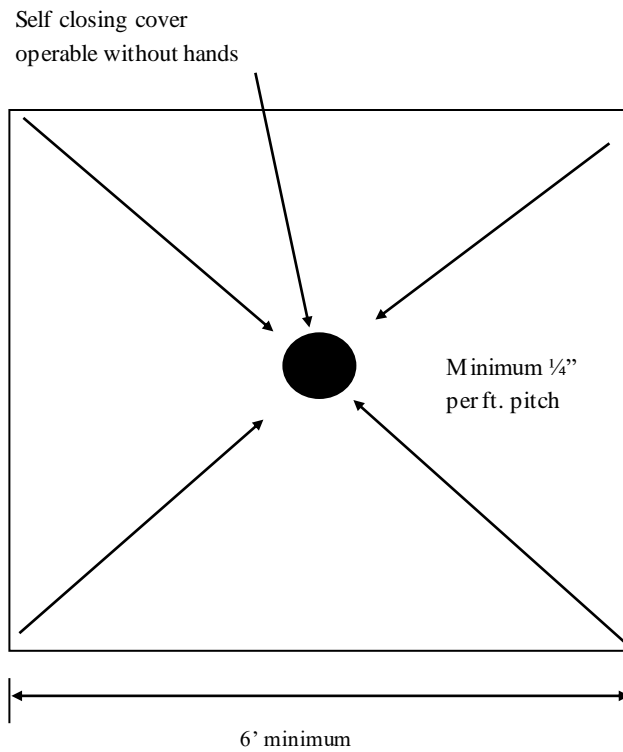

NOTE TO REVISOR: Appendix A-82.40(5) reprinted Table 63.1029 footnote ^a reprinted with an error; below is the corrected text:

^aFor insulation outside the state conductivity range, the minimum thickness (T) shall be determined as follows: $T=PR [(1+t/PR)K/k - 1]$, where T = minimum insulation thickness for material with conductivity K, in.; PR = actual outside radius of pipe, in.; t = insulation thickness, in.; K = conductivity of alternate material at mean rating temperature indicated for eh application fluid temperature; and k = the lower value of the conductivity range listed for eh applicable fluid temperature.

SECTION 242. Appendix A-82.40 (7) (a) is amended to read:

A-82.40 (7) (a) METHODOLOGY.

Where equipment such as an instantaneous or tankless water heater, water treatment device, water meter, and backflow preventer is provided in the design, the friction loss in such equipment, corresponding to the GPM demand, should be determined from the manufacturer or other reliable source.

Where a direct fired pressurized tank type water heater is provided in the design, the friction loss for such equipment can be assumed as part of the pressure losses due to flow through piping, fittings, valves and other plumbing appurtenances when the developed length of piping is multiplied by 1.5.

The pressure losses due to flow friction through displacement type cold-water meters may be calculated from Graph A-82.40 (7)-1.

[Note to Revisor: New graph only.]

Graph A-82.40 (7) - 1
PRESSURE LOSS IN COLD-WATER METERS, DISPLACEMENT TYPE

MAXIMUM CAPACITY AND PRESSURE LOSS
AS PER AWWA 6700-64

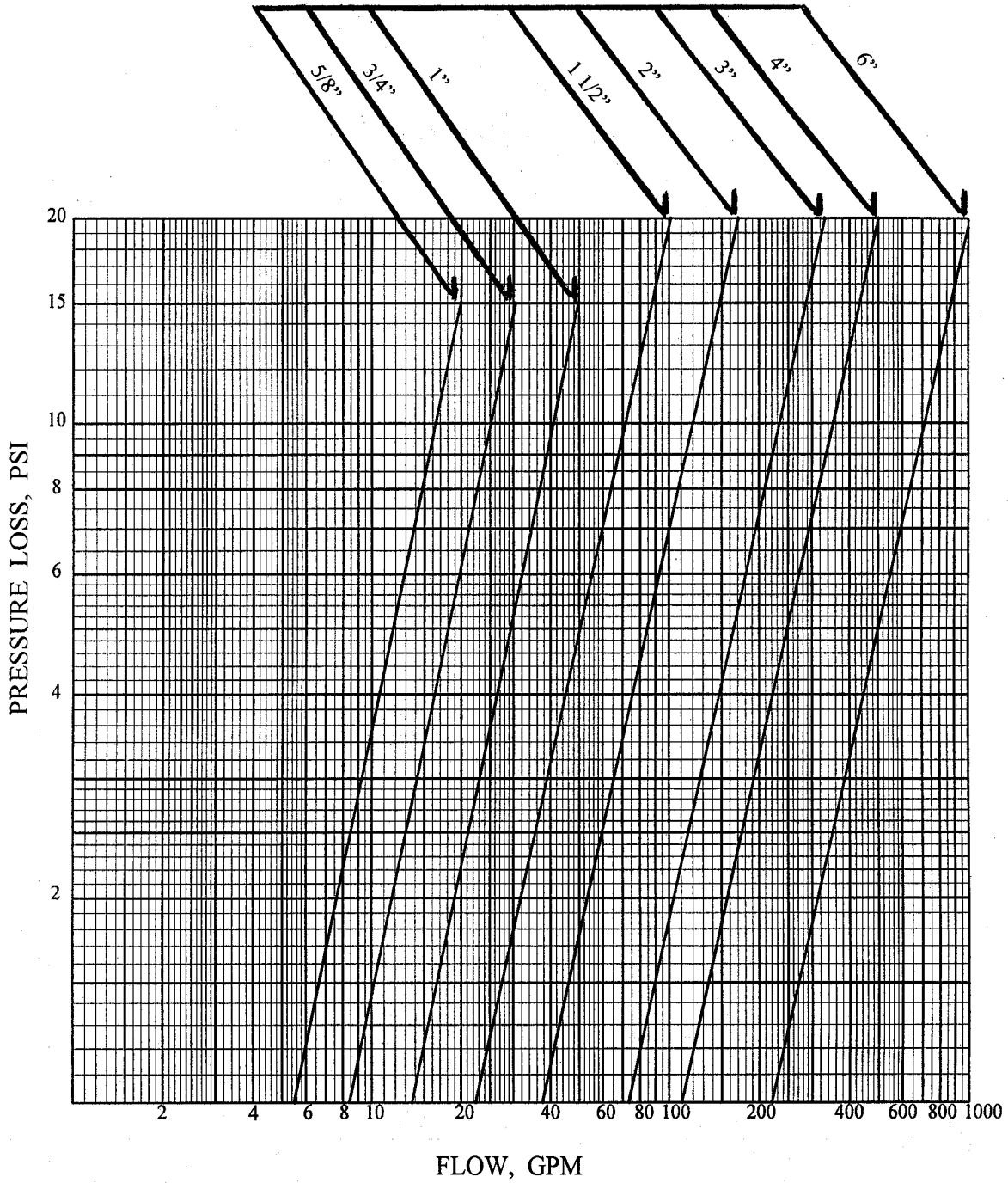

SECTION 243. Appendix A-82.40 (7) (b) Graphs A-82.40 (7)-2 to -11 are repealed and recreated to read:

A-82.40 (7) (b) Private water mains and water services. Graphs A-82.40 (7)-1 to A-82.40 (7)-11 may be used to size private water mains and water services.

Graph A-82.40 (7)-2
 Pressure losses due to flow friction
 Material: Copper Tube-Type K, ASTM B88; (C = 150)

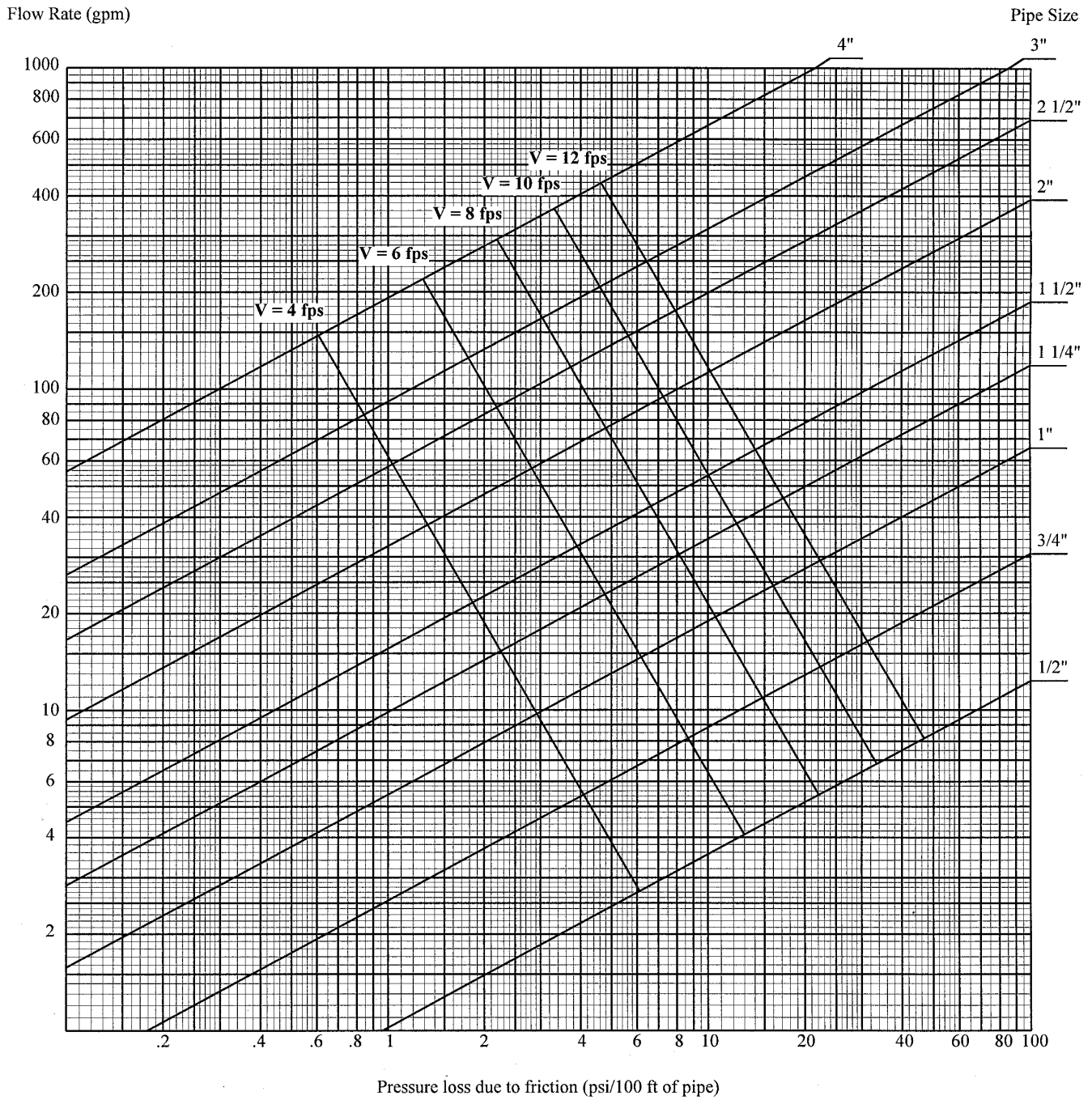

Graph A-82.40 (7)-3
 Pressure losses due to flow friction
 Material: Copper Tube-Type L, ASTM B88; (C = 150)

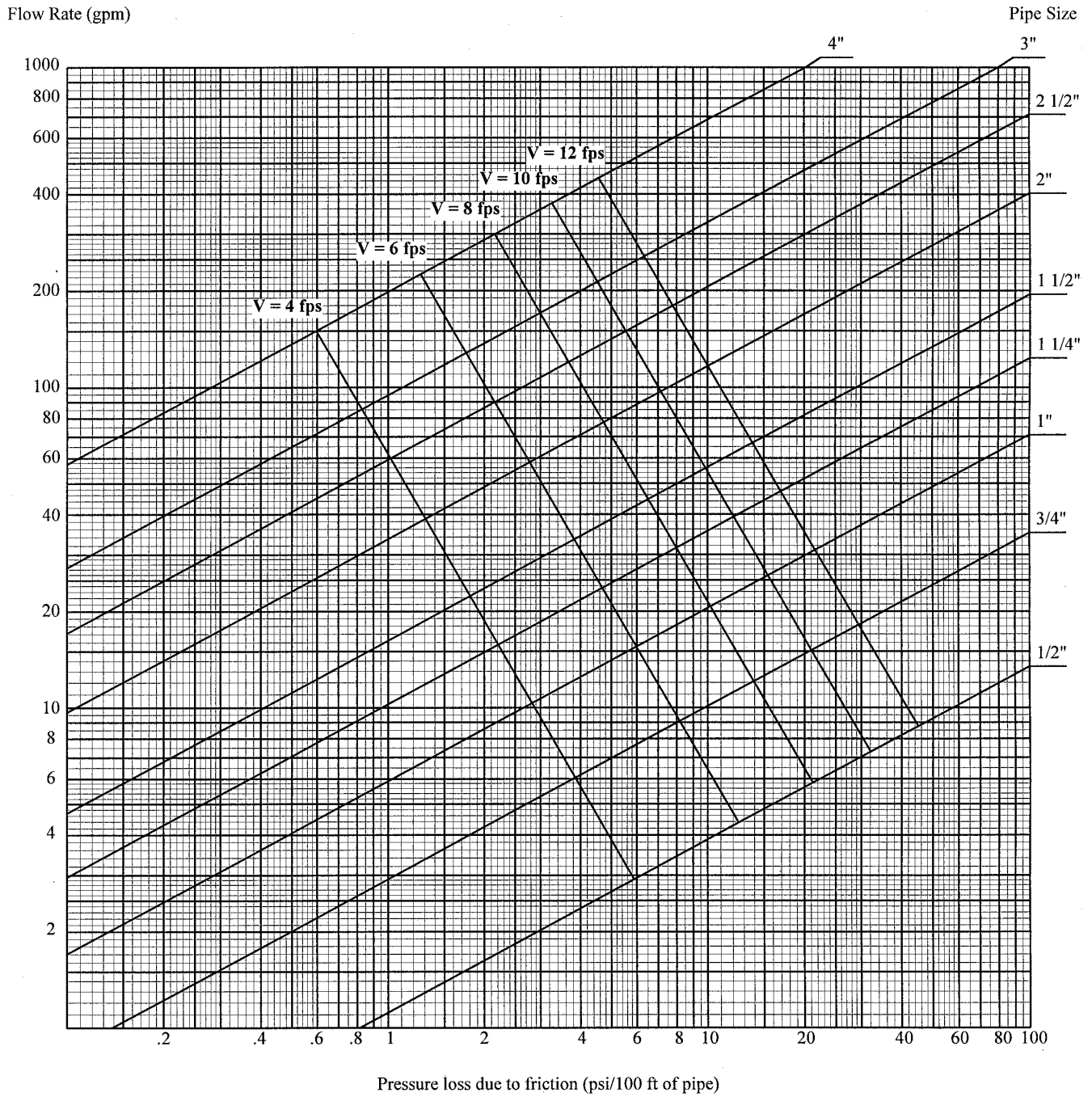

Graph A-82.40 (7)-4
 Pressure losses due to flow friction
 Material: Galvanized Steel Pipe-Schedule 40, ASTM A53, ASTM A120; (C = 125)

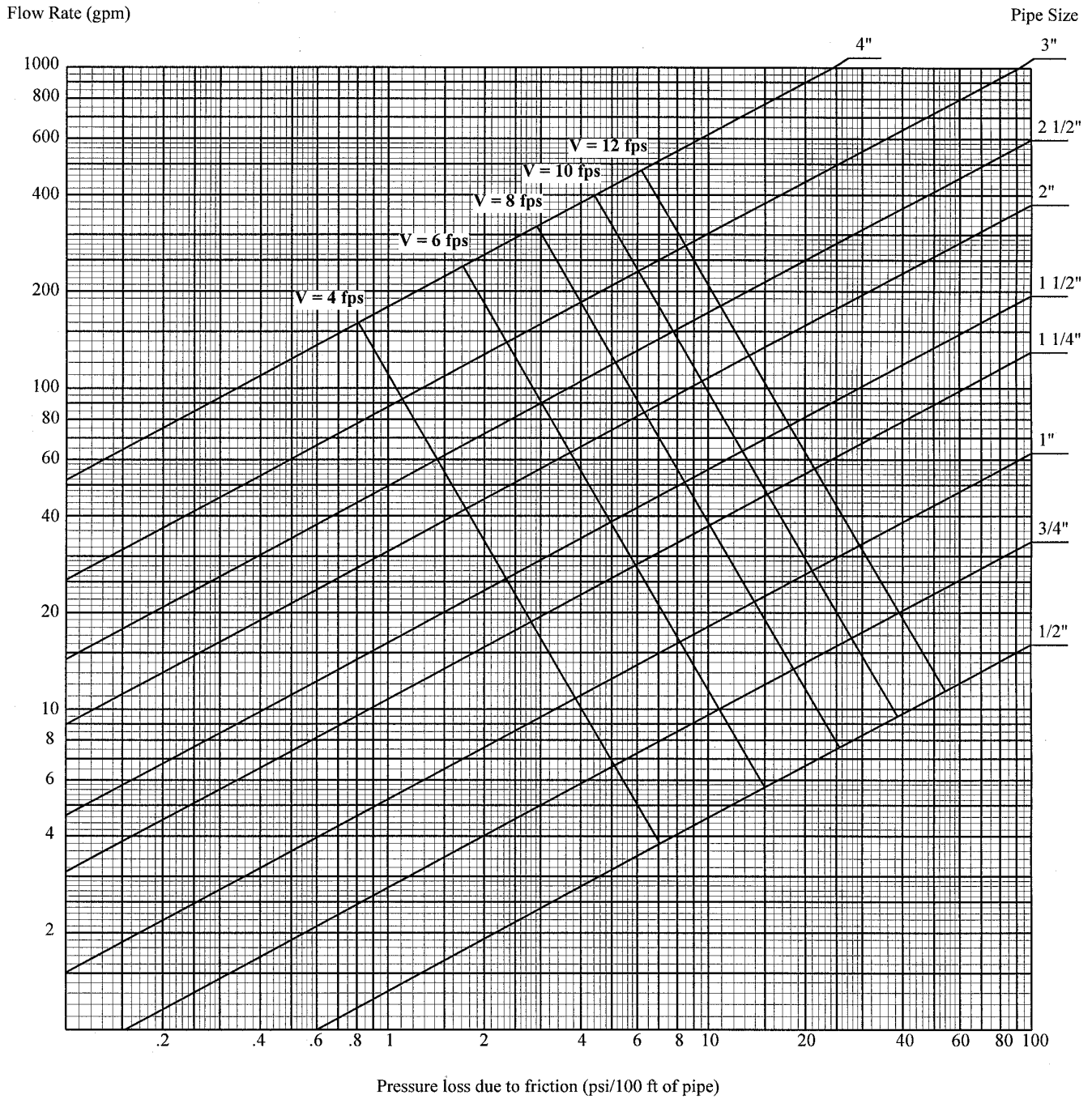

Graph A-82.40 (7)-5
 Pressure losses due to flow friction
 Material: Polybutylene Tubing, ASTM D3309; or
 CPVC Tubing, ASTM D2846; (C = 150)

Flow Rate (gpm)

Pipe Size

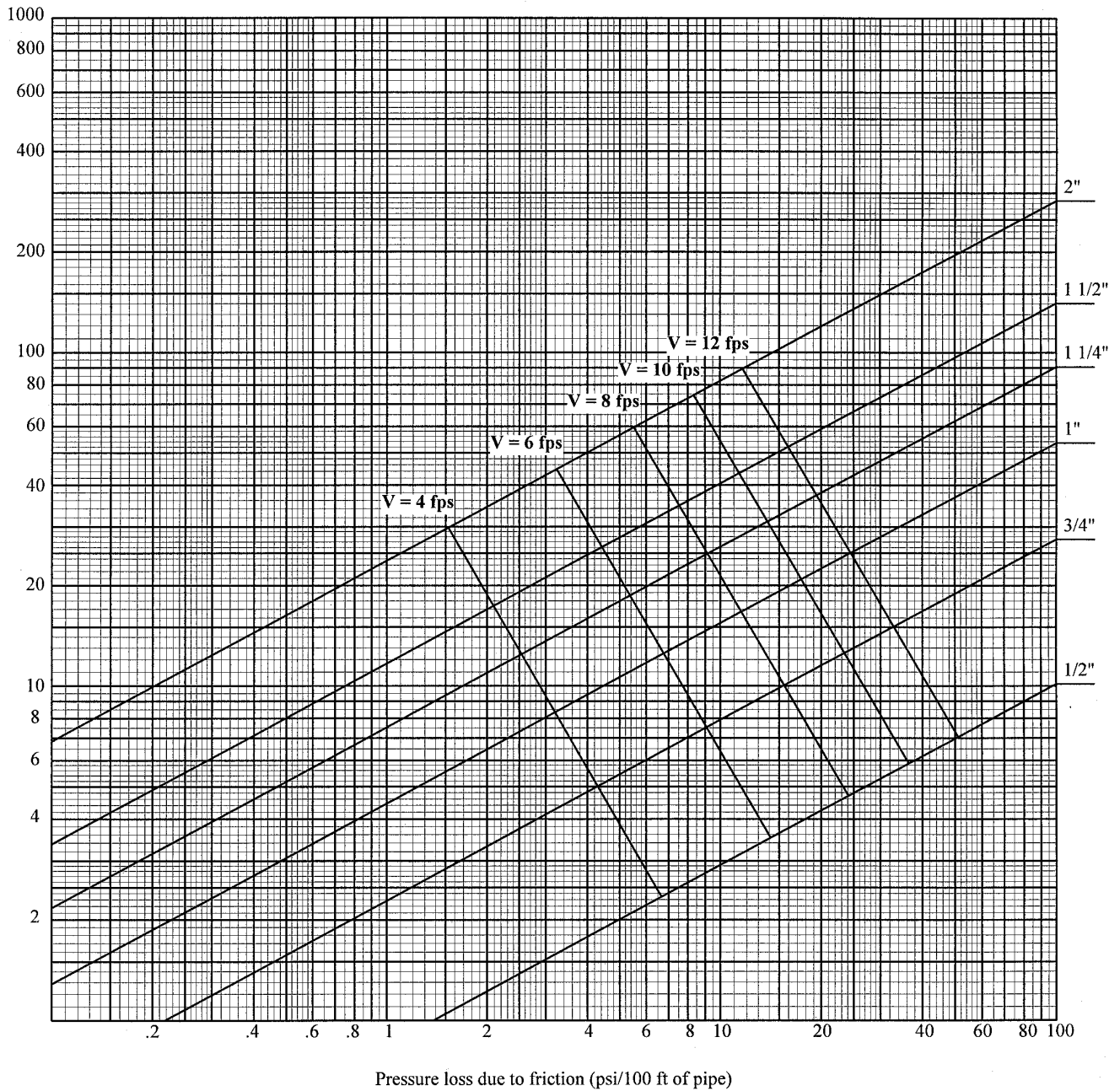

Graph A-82.40 (7)-6
 Pressure losses due to flow friction
 Material: Crosslinked Polyethylene (PEX) Tubing, ASTM F876; (C = 150)

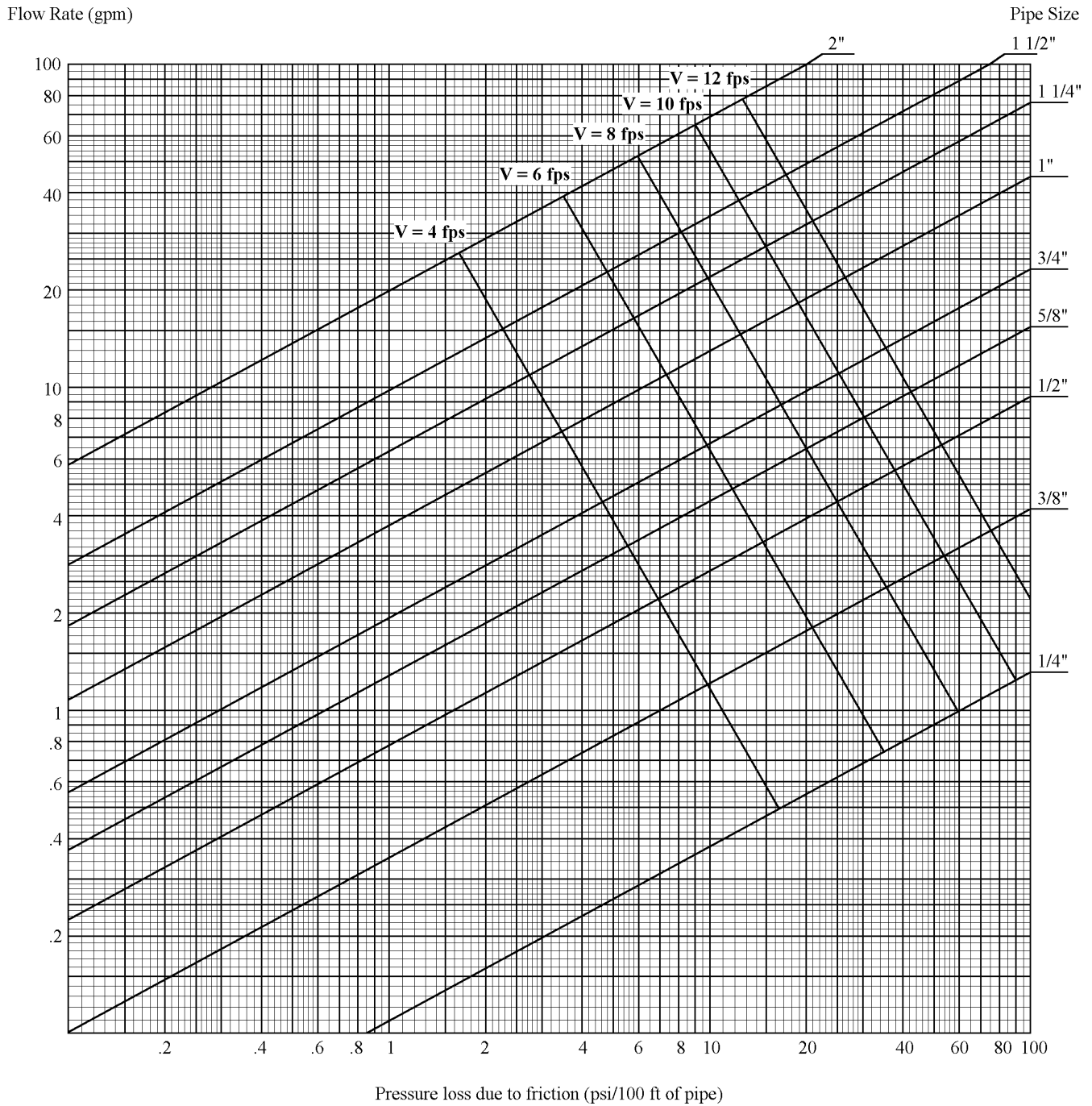

Graph A-82.40 (7)-7

Pressure losses due to flow friction

Material: Polyethylene Tubing, Copper Tube Size, ASTM D2737; (C = 150)

Flow Rate (gpm)

Pipe Size

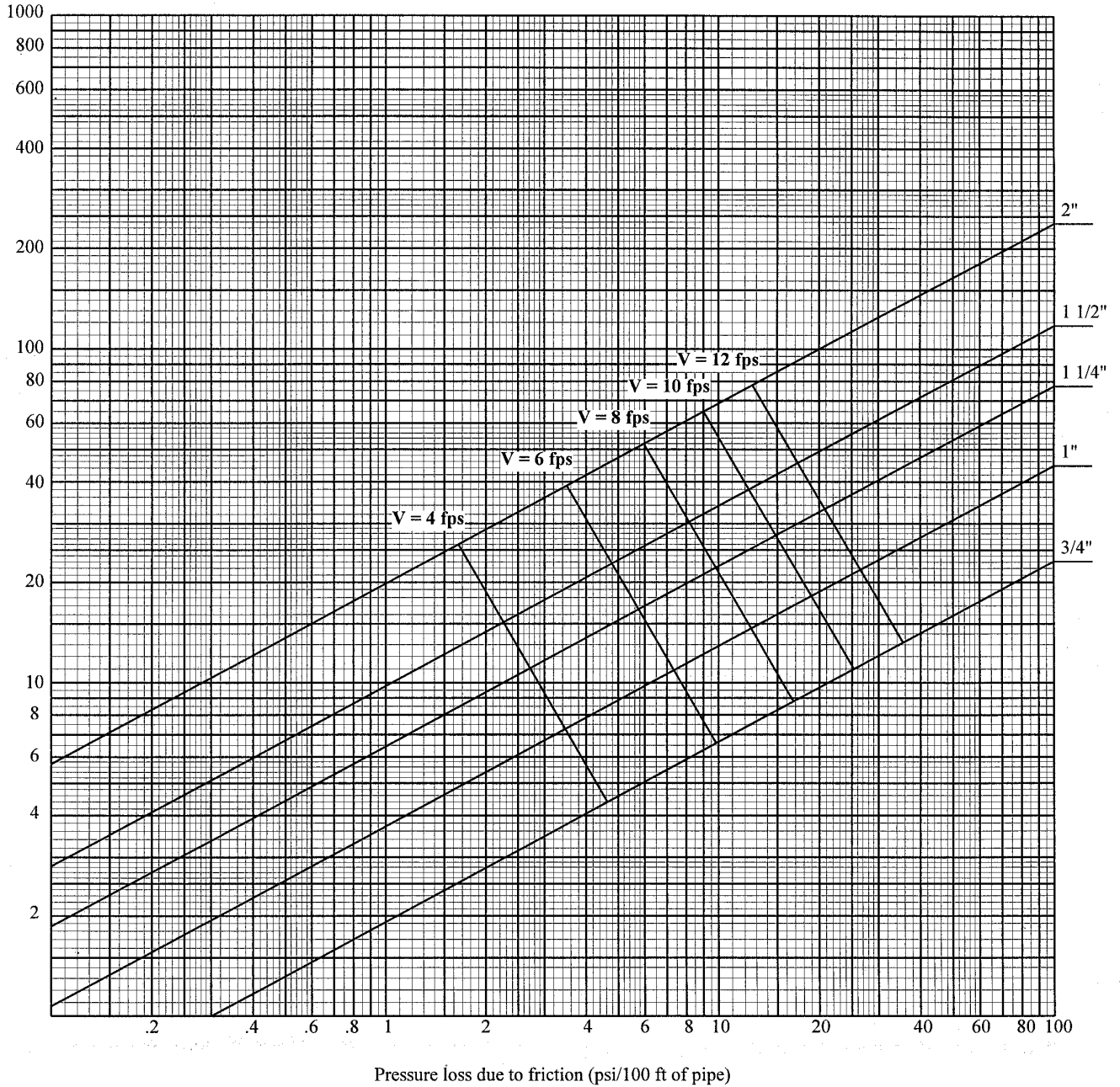

Graph A-82.40 (7)-8

Pressure losses due to flow friction

Material: ABS Pipe-Schedule 40; ASTM D1527; or

CPVC Pipe-Schedule 40; ASTM F441; or

PE Pipe-Schedule 40; ASTM D2104; ASTM D2447; or

PVC Pipe-Schedule 40; ASTM D1785; ASTM D2672; (C =150)

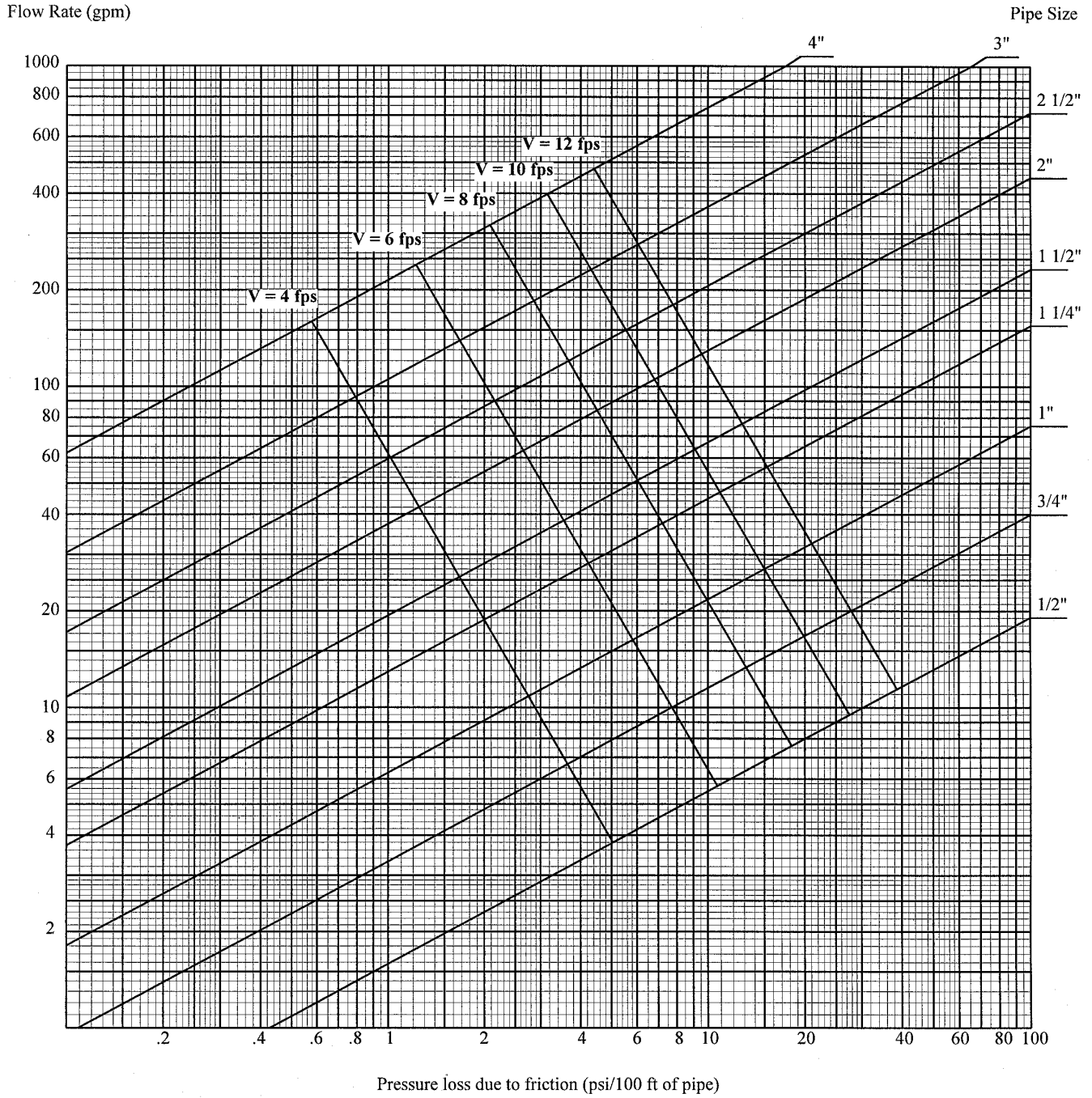

Graph A-82.40 (7)-9
 Pressure losses due to flow friction
 Material: Copper Tube-Type M, ASTM B88; (C = 150)

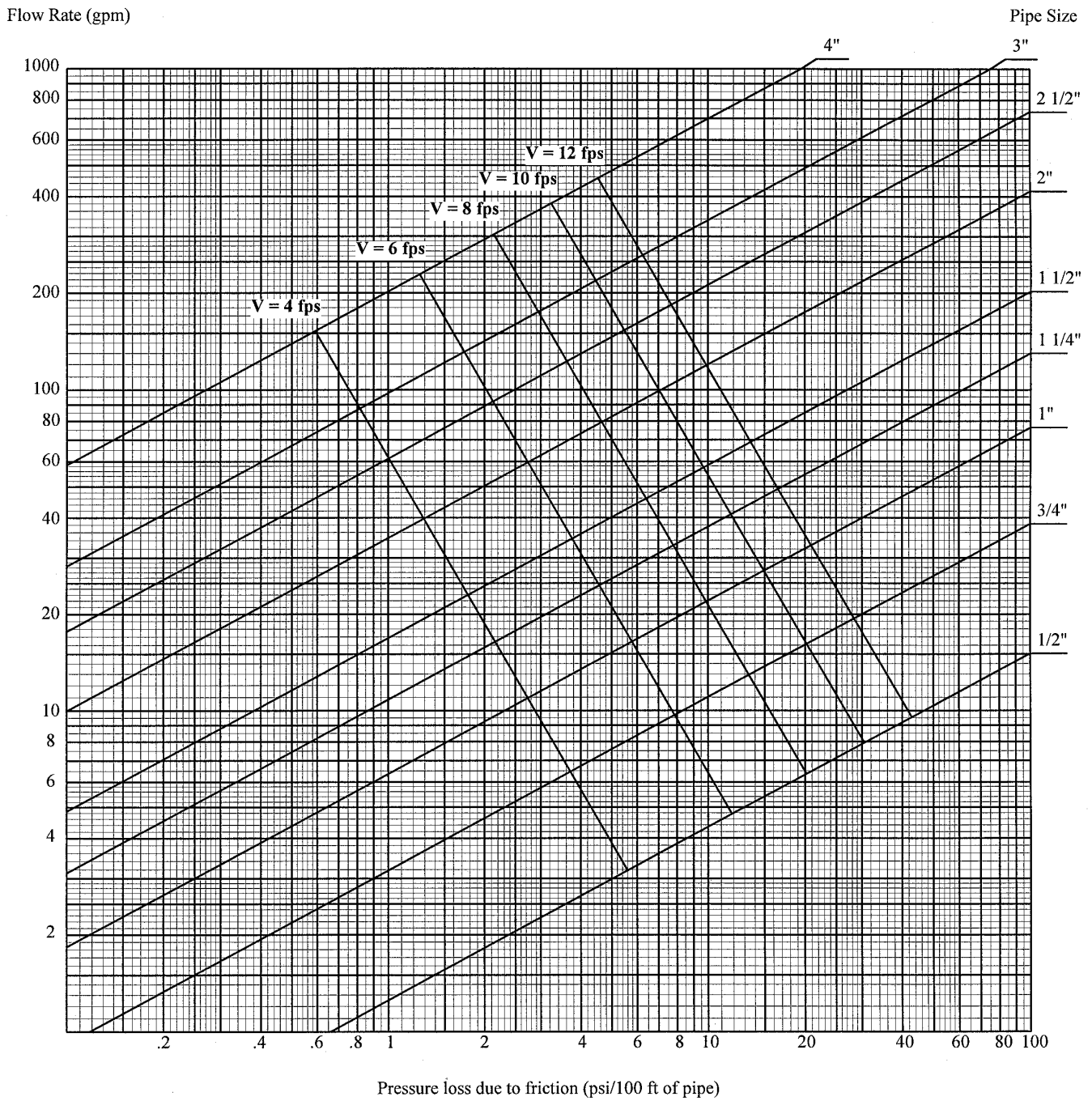

Graph A-82.40 (7)-10

Pressure losses due to flow friction

Material: Polyethylene Aluminum Polyethylene Tubing (PexAlPex), ASTM F1281; (C = 150)

Flow Rate (gpm)

Pipe Size

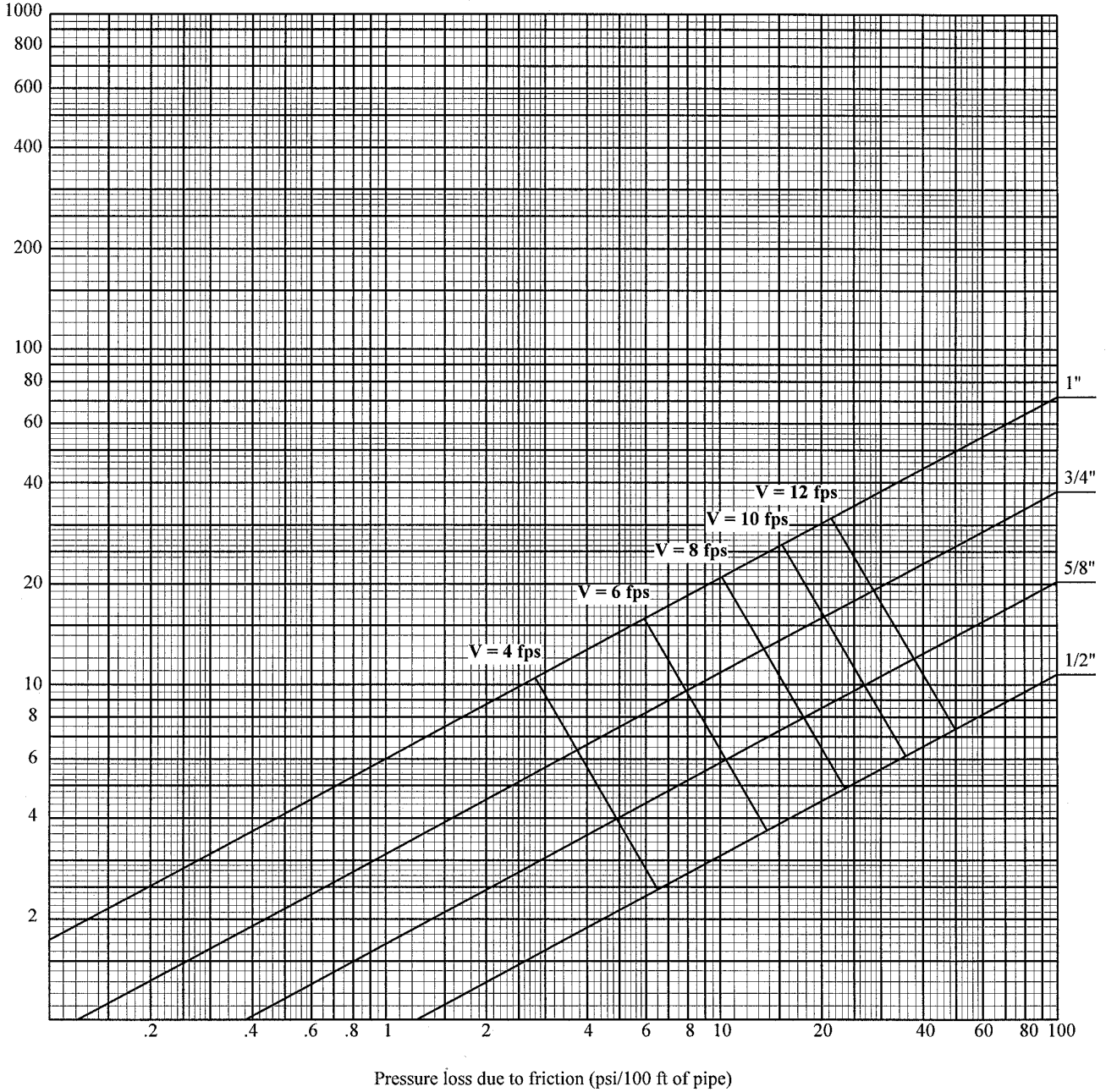

Graph A-82.40 (7)-11
 Pressure losses due to flow friction
 Material: CPVC Tubing, SDR 13.5; ASTM F442; (C = 150)

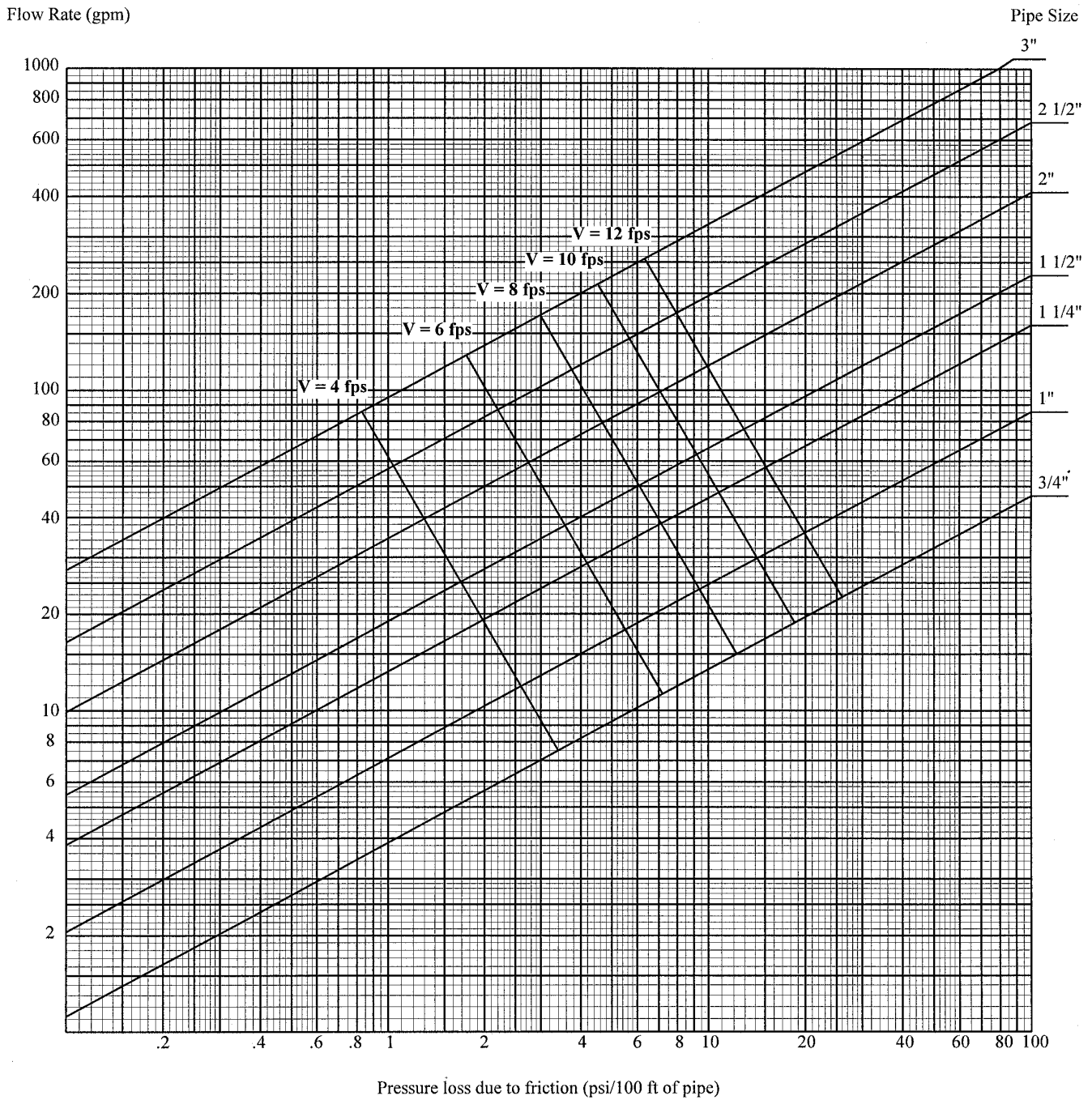

SECTION 244. Appendix A-82.50 (3) is created to read:

A-82.50 (3) (b) 6. OPTIONS FOR TEMPERATURE CONTROL IN HEALTH CARE FACILITIES. The following sketches provide options for fail safe installations at the bathing and shower fixture and temperature control at handwashing fixtures.

Option 1. Fail safe solenoid meeting ASSE 1016/1017 provided at main mixer with pressure balance and limit stop faucets.

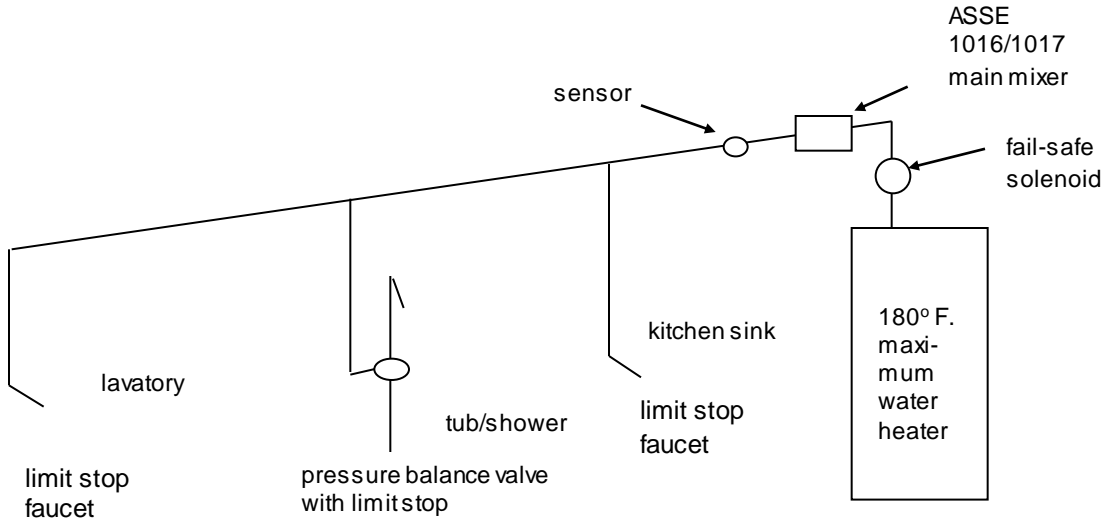

Option 2. Fail safe solenoid provided at main mixer with thermostatic mixer faucets.

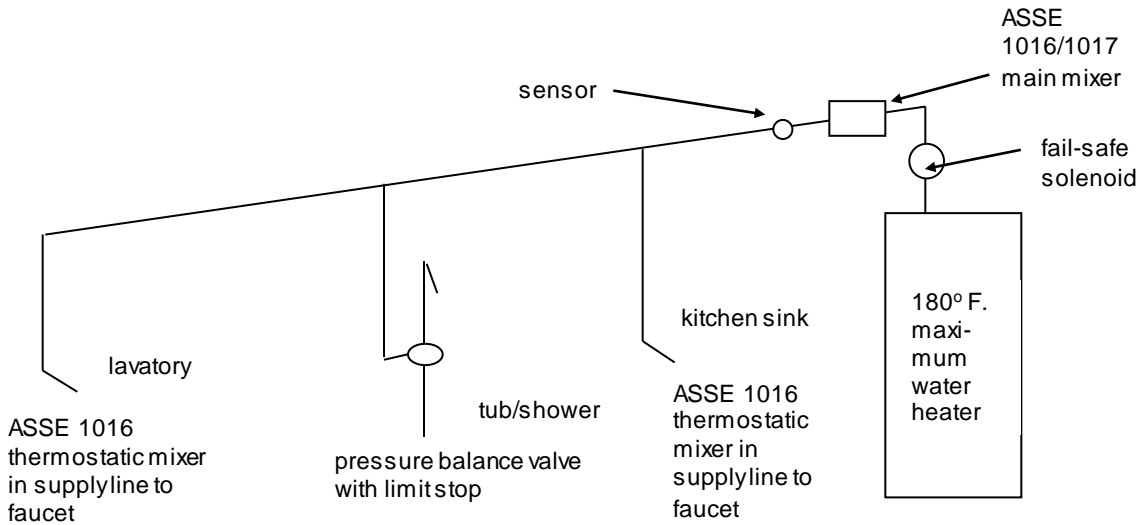

Option 3. Fail safe solenoid provided at main mixer with combination faucets.

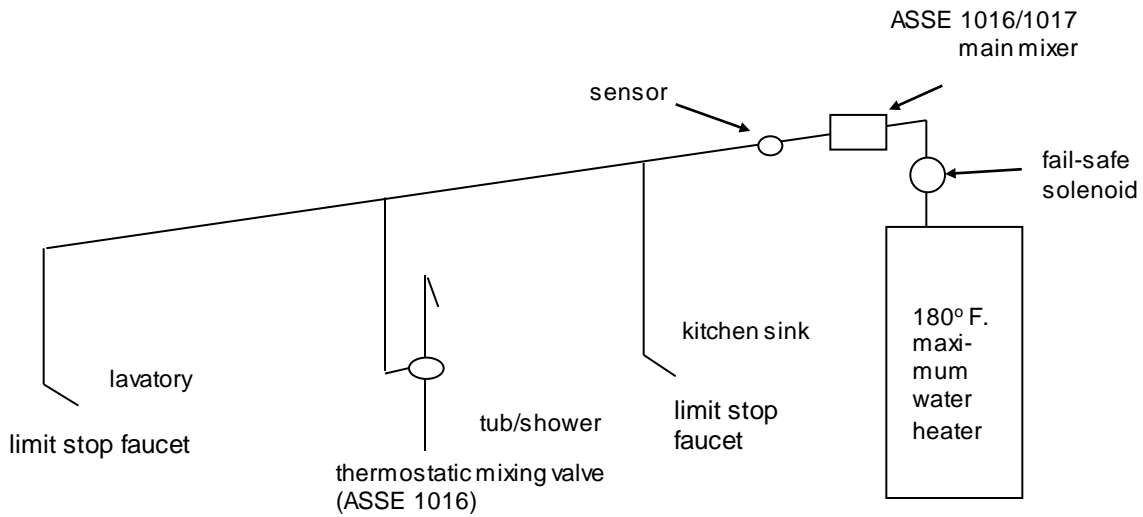

Option 4. Fail safe solenoid provided at main mixer with combination thermostatic/pressure balance mixing valve and limit stop faucets.

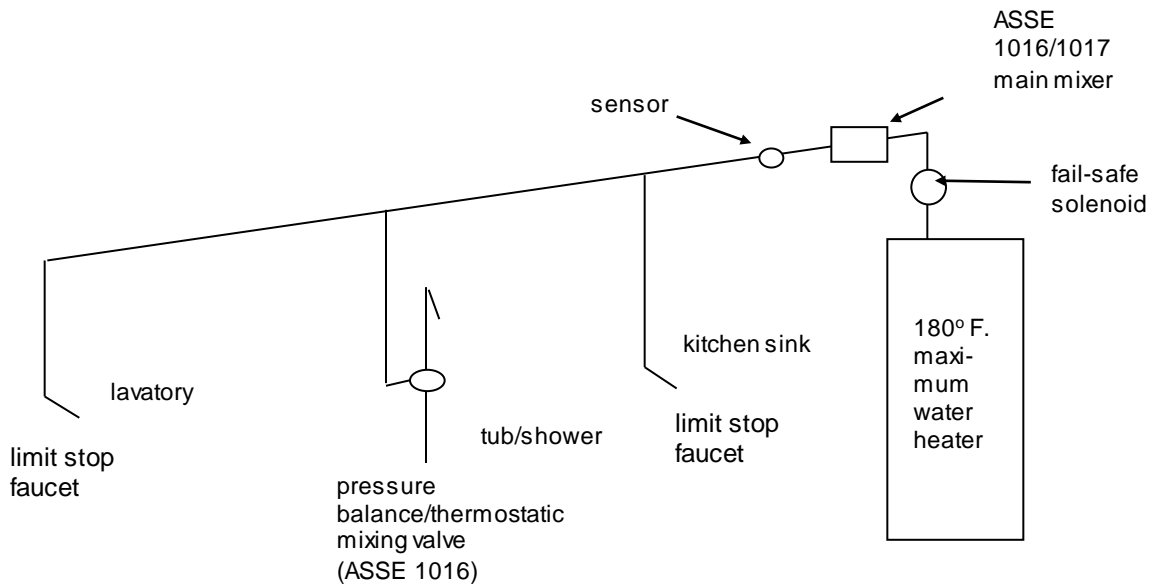

Option 5. Fail safe solenoid and ASSE 1016 thermostatic mixers.

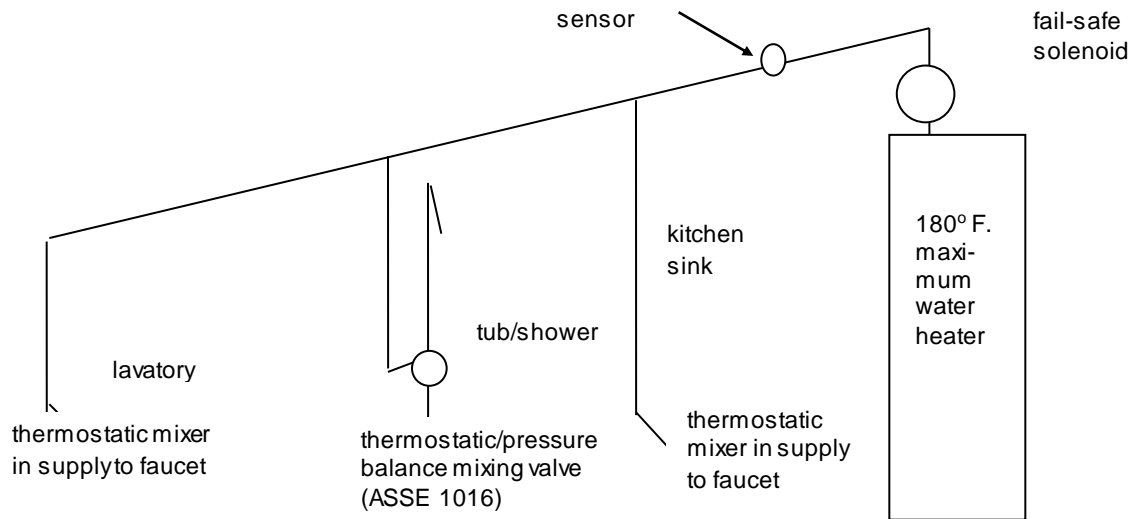

SECTION 245. Appendix A-84.10 (3) (b) is amended to read:

A-84.10 (3) (b) Request forms for voluntary POWTS product approval may be obtained at the following locations:

Department of Commerce ~~Offices~~

Madison Office

201 W. Washington Ave.

PO Box 7162

Madison, WI 53707-7162

Phone (608) 266-3151

Web page <http://www.commerce.state.wi.us/SB/SB-DivForms.html>

SECTION 246. Appendix A-84.20 (5) Figures 84.20-2 (title) and 84.20-4 (title) are amended to read:

Figure A-84.20-2. Spacing between ~~stall-type~~ urinals.

Figure A-84.20-4. Spacing between ~~wall-hung or stall-type~~ urinals.

SECTION 247. Appendix A-84.30 (4) (e) 2. is created to read:

A-84.30 (4) (e) 2. TURF SPRINKLER SYSTEM PIPING MATERIAL.

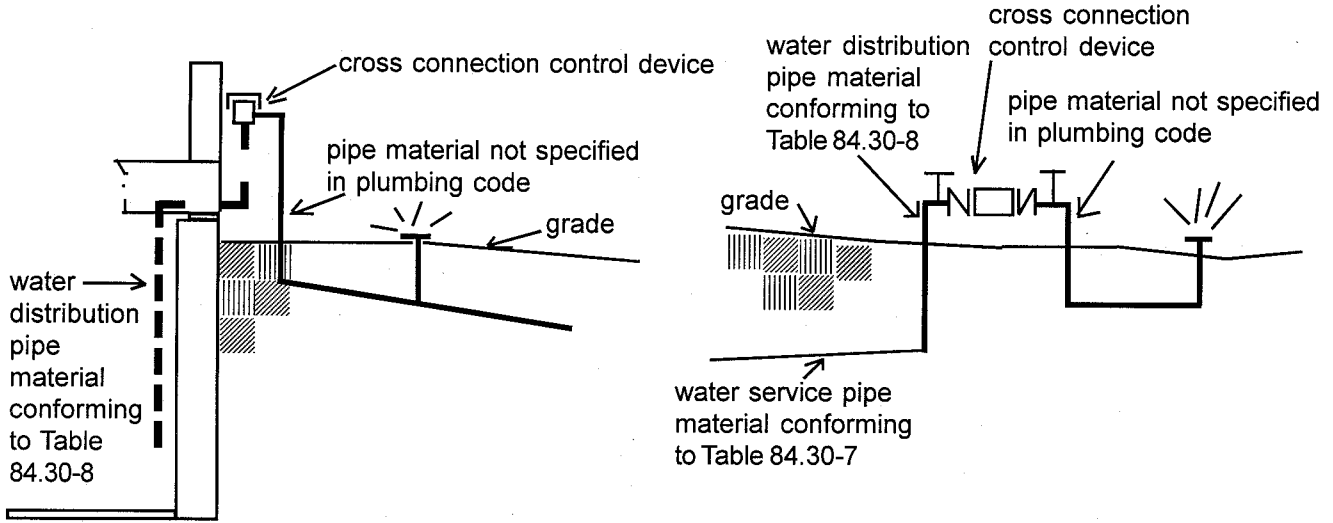

Turf sprinkler system piping material

EFFECTIVE DATE

Pursuant to s. 227.22 (2) (intro.), Stats., these rules shall take effect on the first day of the month following publication in the Wisconsin Administrative Register.

(end)